

HARTMETALL-BESTÜCKTE KREISSÄGEBLÄTTER

METALLKREISSÄGEBLÄTTER · HSS-DMo5 · HSS-Co5 · HSS-DIN · VOLLHARTMETALL

ORBITALE ROHRKREISSÄGEBLÄTTER · PASSEND FÜR: GEORG FISCHER (GF) · AXXAIR · PROTEM · ORBITALUM · EXACT

CARBIDE TIPPED CIRCULAR SAW BLADES

METAL CIRCULAR SAW BLADES · HSS-DMo5 · HSS-Co5 · HSS-DIN · SOLID CARBIDE

ORBITAL PIPE CUTTING CIRCULAR SAW BLADES · SUITABLE FOR: GEORG FISCHER (GF) · AXXAIR · PROTEM · ORBITALUM · EXACT

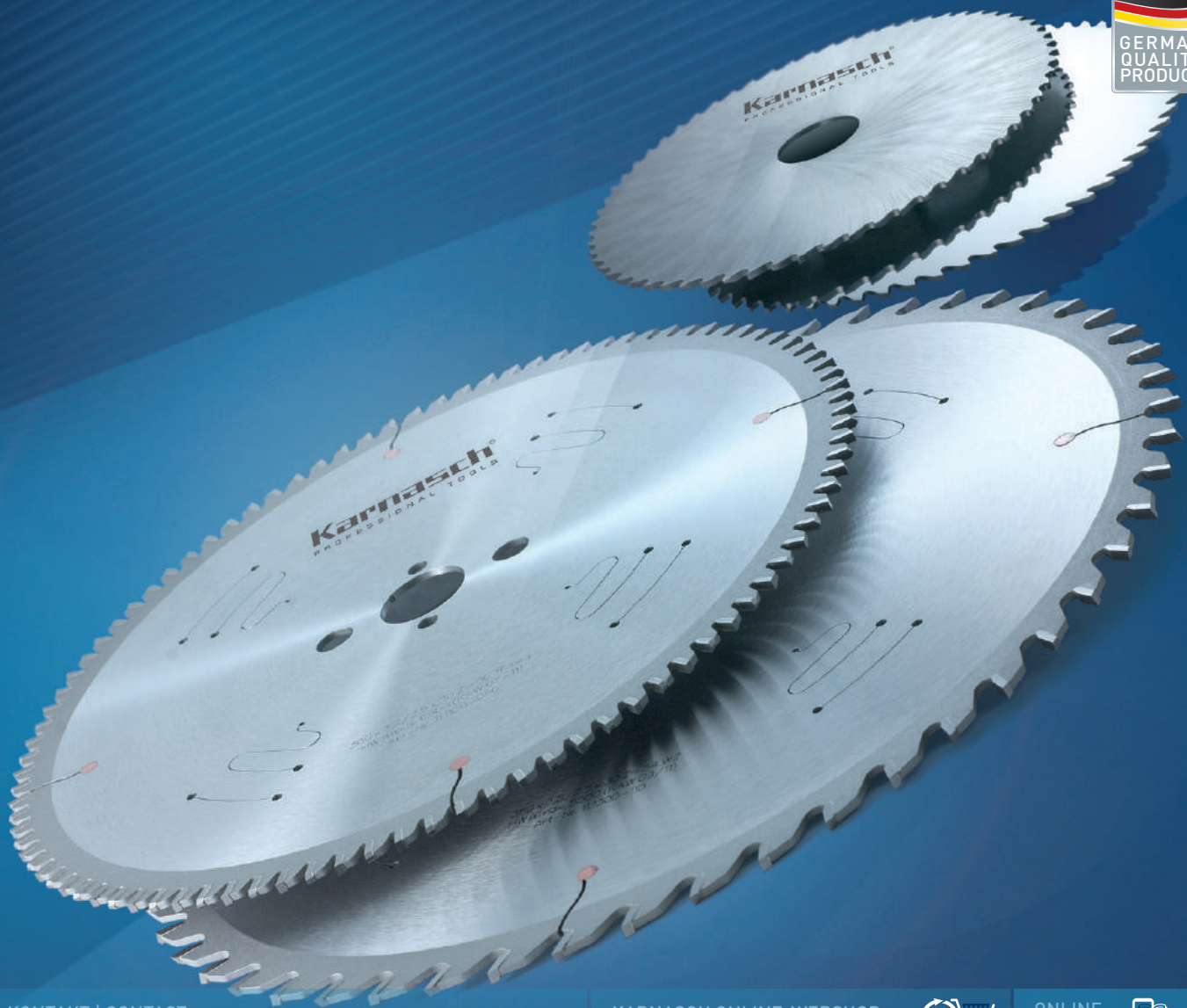

- 1
- 2
- 3
- 4
- 5
- 6
- 7
- 8
- 9
- 10

KONTAKT | CONTACT

KARNASCH PROFESSIONAL TOOLS[®]
INDUSTRIAL TOOLS DIVISION

Straße des Friedens 10
D-15848 Tauche/OT Görzdorf
mail@karnasch.tools

+49 (0) 33675 - 7265-0

KARNASCH ONLINE-WEBSHOP

JETZT FÜR SIE ONLINE!
NOW ONLINE FOR YOU!

<http://shop.karnasch.tools>



ONLINE



HARTMETALL-BESTÜCKTE KREISSÄGEBLÄTTER

CARBIDE TIPPED CIRCULAR SAW BLADES

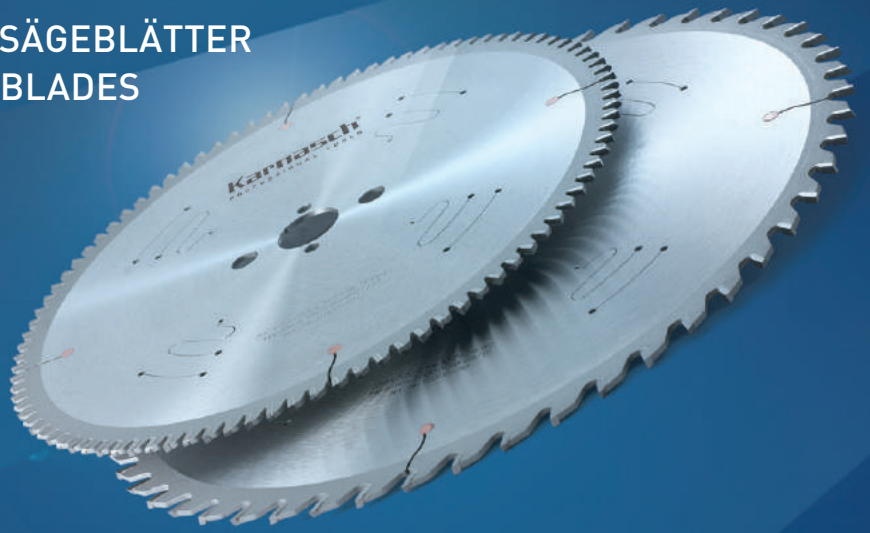

Inhaltsverzeichnis · Contents

	Zeichenerklärung Qualitätsstandard	Key to symbols Quality standard	478
	Schnellfinder	Quick finder	480/481
	Finder nach Artikelnummer aufsteigend + Anwendung	Finder by article numbers ascending + application	482-485
	Finder nach Blatt-Ø aufsteigend + Anwendung	Finder by blade-Ø + application	486-523
	Maschinenhersteller alphabetisch mit passendem Blatt-Ø + Bohrung-Ø	Machine manufacturer in alphabetical order with matching blade-Ø + bore-Ø	524-529
	Reduzierringe, geschliffen, außen gerändelt, Passung H7	Reduction rings, ground, knurled outward, H7 fit	709
	Sägen-Sets und Displays	Saw blade kits and displays	710
	Kühl- und Schmiermittel	Coolants and lubricants	711-715



Art.
100
101
102

METALLKREISSÄGEBLÄTTER

HSS-DMo5 · HSS-Co5 · HSS-DIN · VOLLHARTMETALL

METAL CIRCULAR SAW BLADES

HSS-DMo5 · HSS-Co5 · HSS-DIN · SOLID CARBIDE

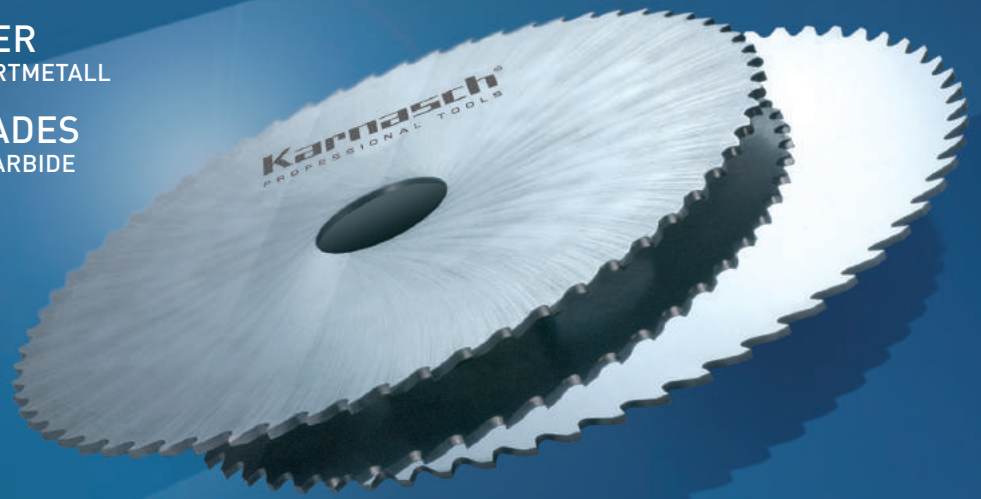

Inhaltsverzeichnis · Contents

	<p>Metallkreissägeblätter HSS-DMo5 HSS-Co Cobalt + Beschichtung Kx</p>	<p>Metal circular saw blades HSS-DMo5 HSS-Co Cobalt + Coated Kx</p>	<p>677-692</p>
	<p>Metallkreissägeblätter nach DIN</p>	<p>Metal circular saw blades according DIN</p>	<p>693-698</p>
	<p>Vollhartmetall-Kreissägeblätter nach DIN</p>	<p>Solid carbide circular saw blades according DIN</p>	<p>699-705</p>
	<p>Orbitale Rohrkreissägeblätter für Maschinen von: Georg Fischer (GF) · AxxAir · Protem · Orbitalum · Exact</p>	<p>Orbital pipe cutting circular saw blades for machines from: Georg Fischer (GF) · AxxAir · Protem · Orbitalum · Exact</p>	<p>706-707</p>
	<p>Kreissägeblätter Aufnahmehalter / Fräsdorne</p>	<p>Circular saw blade retainer / milling arbors</p>	<p>708</p>

1



2



3



4



5



6



7



8



9



10



Art.
100
101
102



Zeichenerklärung
Key to symbols

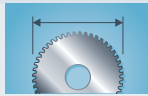

Ø mm

Ø mm



Schnittbreite &
Stammblattstärke

Cut width, thickness
of saw body



Bohrung Ø mm
Toleranz H7

Bore Ø mm
tolerance H7

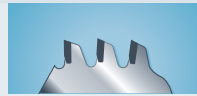

Zähnezahl
Zahnform

Number of teeth/
tooth configuration



Nebenlöcher

Pinholes



Extrem Geräusch +
Vibrationsgedämmt

Extreme noise +
vibration dampened



Gewuchtet

Balanced out

- Lagerware
Marchandise stockée
- Keine Lagerware, Lieferzeit und Preis auf Anfrage
No stock-tool. Price and delivery on request
- ▲ Lieferbar solange Vorrat oder auf Anfrage
Article be discontinued. Delivery possible until sold out. After sold out delivery possible on request

100 % MADE IN GERMANY

Extrem Geräusch & Vibrationsgedämmt
wo technisch sinnvoll

Extreme noise & vibration
dampened in case of needed

Gewuchtet wo
technisch sinnvoll

Balanced in case
of needed

100 % Qualitätskontrolle

100 % quality control

Alle Blätter in höchster
Qualitätsstufe gefertigt

All blades manufactured
to the highest quality level

Einblicke der High-Tech Fertigung · Insights our High-Tech Manufacturing



NC-Schleifen · NC grinding

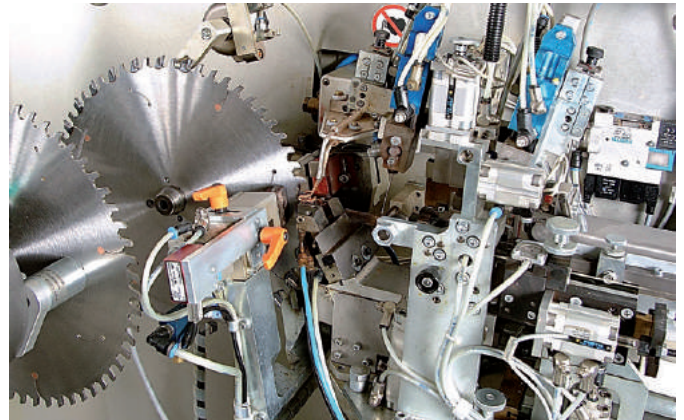

NC-Löten · NC soldering

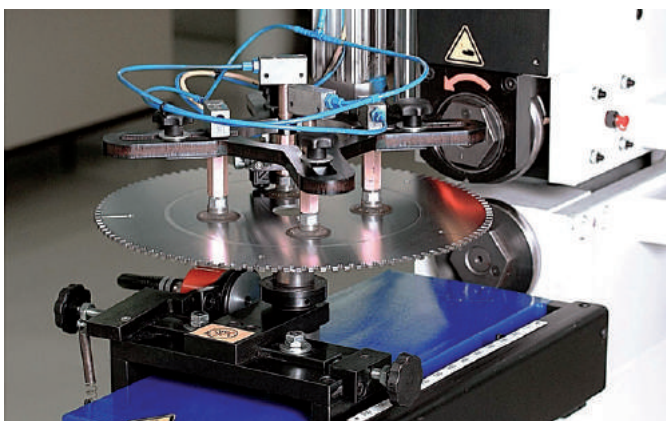

Spannungsring walzen · Making of the tension ring

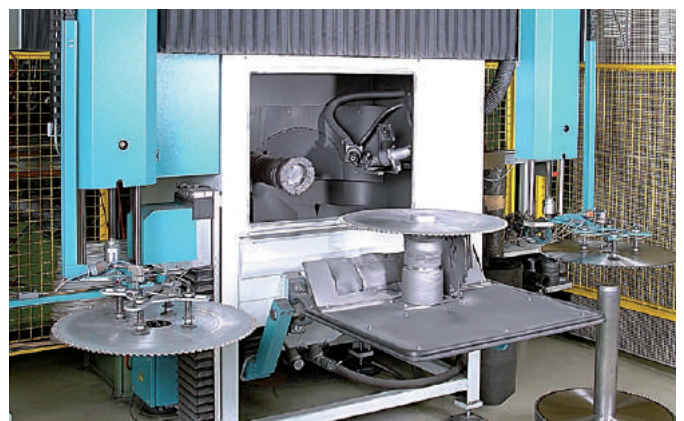

Sandstrahlen · Sandblasting

- 1
- 2
- 3
- 4
- 5
- 6
- 7
- 8
- 9
- 10

Art.
100
101
102

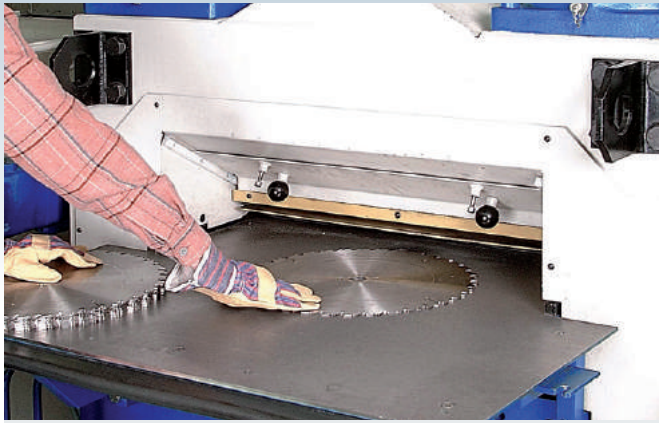

Richten · Straighten of the blades



Feinrichten · High-precision straightening of the blades

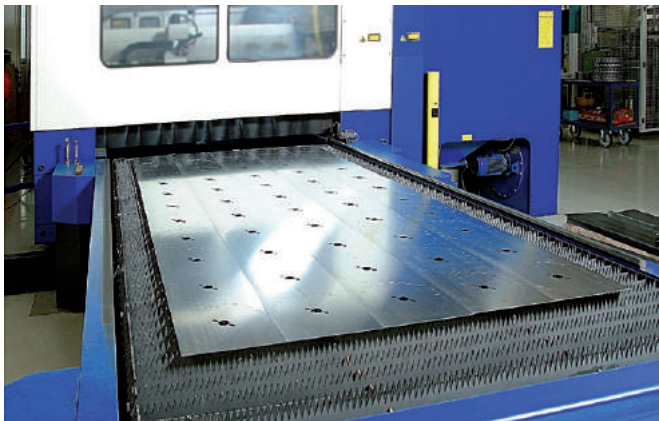

Lasern Stufe 1 · Sawbody laser step 1



Lasern Stufe 2 · Sawbody laser step 2

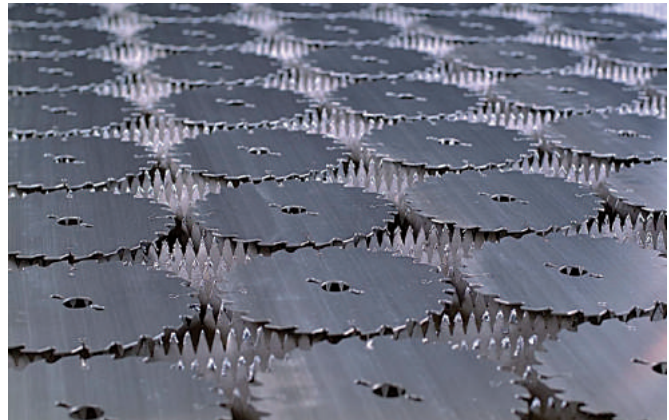
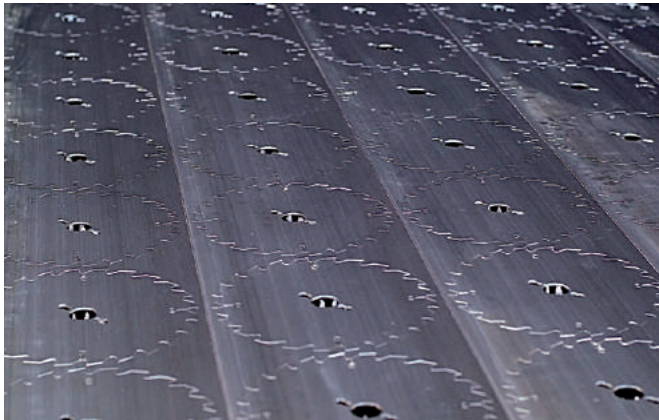

Anlassofen · Tempering Furnace



Lautstärke Messung · Measure of the Volume

- 1
- 2
- 3
- 4
- 5
- 6
- 7
- 8
- 9
- 10

Art.
100
101
102



Schnellfinder

	Ø mm von-bis	Anwendung / Material	
1 Großanlagen und Produktionsmaschinen Kreissägeblätter für: Edelstahl · Stahl · Guss · Ne-Metalle	Ø 250–1560 mm 		530-535
Baustahl · Edelstahl · Dünoblech · Sandwichmaterial	Ø 136–500 mm 		536-543
Aluminium · Kupfer · Messing · Bronze	Ø 120–550 mm 		544-555
Kunststoffe	Ø 120–400 mm 		556-587
Fensterprofile (auch mit Gummidichtung)	Ø 120–600 mm 		564-573
Bau · Universal	Ø 120–700 mm 		588-601
Abrasive Werkstoffe (zu schnellem Schneidenschleiß führende Materialien)	Ø 120–500 mm 		602-611
Plattenaufteilung (Formatieren) großflächig	Ø 125–450 mm 		612-615
Formatieren	Ø 120–500 mm 		616-645
Massivholz	Ø 120–800 mm 		646-665
Handkreissägen + Lamello	Ø 100–355 mm 		666-668
Vorritzen (Ritzer)	Ø 80–125 mm 		669
Glasleisten (Glasleisten Kreissägen)	Ø 92–400 mm 		670/671
Kreissägen für Straßenrand Freischneider / Böschungsmäher von Mulag, Spearhead, Power usw.	Ø 390–600 mm 		672
Kreissägen für Vogesenblitz Trommelsäge SAT 4-700	Ø 700 mm 		673
Kreissägen für Orbitale Rohrsägen von Georg Fischer (GF) · Axxair · Protem · Orbitalum · Exact	Ø 63–165 mm 		674/675
Nuten	Ø 200–250 mm 		676

- 1
- 2
- 3
- 4
- 5
- 6
- 7
- 8
- 9
- 10

Art.
100
101
102



Quickfinder

	Ø mm from-to	Application / Material	
Large-scale industrial sawing-machine/production machine blades for: Stainless steel · Steel · Cast iron · Non-ferrous metals	Ø 250–1560 mm 	  	530-535
Mild steel · Stainless steel · Thin iron sheets · Sandwich material	Ø 136–500 mm 	  	536-543
Aluminium · Copper · Brass · Bronze	Ø 120–550 mm 	 	544-555
Plastics	Ø 120–400 mm 	 Plastic	556-587
Window profiles (also with rubber seal)	Ø 120–600 mm 		564-573
Construction · Universal	Ø 120–700 mm 	  	588-601
Abrasive materials (materials difficult to machine and causing high cutting wear)	Ø 120–500 mm 	  	602-611
Panel sizing large-scale	Ø 125–450 mm 		612-615
Panel-sizing	Ø 120–500 mm 	  	616-645
Solid wood	Ø 120–800 mm 		646-665
Portable circular saws + Lamello	Ø 100–355 mm 		666-668
Scoring	Ø 80–125 mm 		669
Glazing beads (Glass ledge blades)	Ø 92–400 mm 		670/671
Circular saws for roadside maintenance hedging and sliding machines from Mulag, Spearhead, Power etc.	Ø 390–600 mm 		672
Circular saws for Vogesenblitz cylinder circular barrel saw SAT 4-700	Ø 700 mm 		673
Circular saws for Orbital pipe cutting machines such as: Georg Fischer (GF) · Axxair · Protem · Orbitalum · Exact	Ø 63–165 mm 	 Tube	674/675
Grooving	Ø 200–250 mm 		676

1



2



3



4



5



6



7



8



9



10



Art.
100
101
102



Art.
100
101
102
↓

Finder nach Artikelnummer aufsteigend + Anwendung

Finder by article numbers ascending + application

✓ OPTIMAL OPTIMAL ✓ GUT GOOD ✓ MÖGLICH POSSIBLE



Weichholz, Hartholz, Exotenholz, Quer	Weichholz, Hartholz, Exotenholz, Längs	Holz mit Einschlüssen wie Nägel, Klammern, Beton- und Mörtelreste	Leimholz, Tischler- und Furniersperrholz, Schichtholzplatten	Spanplatten, Hartfaserplatten, Platten ohne Belag LDF, MDF, HDF	Spanplatten, Hartfaserplatten, Kunststoff beschichtet/ furniert, MDF, HDF
Soft wood, hard wood, and exotic wood across the grain	Soft wood, hard wood, and exotic wood along the grain	Wood with inclusions like nails, clips, concrete residues	Bonded wood, blockboard and veneer plywood, laminated wood	Chipboard, hard fibre board, boards without laminate LDF, MDF, HDF	Chipboard, hard fibre board, plastic-coated/ veneered, MDF, HDF

ART.	TYPE								
5.3950	Orbitale Rohrkreissägeblätter Hartmetall-bestückt Orbital pipe cutting circular saw blades carbide tipped	675							
5.3960	Orbitale Rohrkreissägeblätter Cermet-bestückt Orbital pipe cutting circular saw blades cermet tipped	675							
5.3970	Orbitale Rohrkreissägeblätter Diamant-bestreut Orbital pipe cutting circular saw blades diamond-grit	675							
5.3980	Orbitale Rohrkreissägeblätter HSS-Cobalt 5% Orbital pipe cutting circular saw blades HSS-Cobalt 5%	674							
5.3990	Orbitale Rohrkreissägeblätter HSS-Cobalt 5% + Kx beschichtet Orbital pipe cutting circular saw blades HSS-Cobalt 5% + Kx coated	674							
10.7000	Dünnschnitt-Stahlsägen Cermet Thin-Cut steel saws Cermet	532							
10.7001	Dünnschnitt-Stahlsägen Hartmetall-bestückt Thin-Cut steel saws carbide tipped	533							
10.7050	Hochleistungs-Stahlsägen für Großsäganlagen High-Performance steel saws for large-scale industrial sawing machines	535							
10.7100	Dry-Cutter Baustähle Dry-Cutter mild steel	538			✓				
10.7200	Super Dry-Cutter Baustähle Super Dry-Cutter mild steel	539			✓				
10.7300	Dry-Cutter Edelstahl Dry-Cutter stainless	540							
10.7400	Dry-Cutter Sandwich Dry-Cutter sandwich	541							
10.8000	Aluminium + Kunststoffe Universal Aluminium + plastics universal	546	✓		✓				
10.8055	Winkelschleifer + Brutal Einweg-Sägeblätter Angle Grinder + Brutal disposable saw blades	543	✓	✓	✓	✓	✓	✓	✓
10.9000	Kunststoff/Aluminium 7-Zahn Geometrie Plastic 7-tooth geometry	547							
10.9050	Acrylglas (Plexiglas) Klarsichtschnitt Acrylic (Plexiglas) clear cut view	563							
11.1000	Aluminium, Kunststoffe, Fensterprofile · Positiv Aluminium, plastics, window profiles · Positive	565							
11.1050	Aluminium, Kunststoffe, Fensterprofile · Positiv Dünnschnitt Aluminium, plastics, window profiles · Positive Thin cut	567							
11.1100	Aluminium, Kunststoffe, Fensterprofile · Negativ Aluminium, plastics, window profiles · Negative	569							
11.1120	Aluminium, Kunststoffe, Fensterprofile · Negativ Dünnschnitt Aluminium, plastics, window profiles · Negative Thin cut	571							
11.1150	Glasleisten Kreissägeblätter Hartmetall-bestückt Glazing bead (glass ledge) T.C.T. blades	671	✓	✓		✓	✓	✓	✓
11.1170	Glasleisten Kreissägeblätter HSS Glazing bead (glass ledge) HSS blades	671							
11.1200	Zuschnitt Kreissägeblatt · Wechselzahn mit Abweiser Rip saw blade · Alternate top bevel with chip limiter tooth	650	✓	✓		✓	✓		
11.1215	Zuschnitt Kreissägeblatt · Wechselzahn Rip saw blade · Alternate top bevel tooth	651	✓	✓		✓	✓		
11.1220	Zuschnitt Kreissägeblatt · Flachzahn mit Abweiser Rip saw blade · Flat tooth with chip limiter	652	✓	✓		✓	✓		
11.1230	Zuschnitt Kreissägeblatt · Tiefschnitt Rip saw blade · Deep-cut	653	✓	✓		✓	✓		
11.1232	Zuschnitt/Vielblatt mit Räumerschneiden + Abweiser Rip/Multi-rip saw blade with raker teeth + chip limiter	654	✓	✓		✓	✓		



Art.
100
101
102
↓

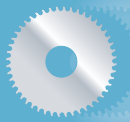

Art.
100
101
102

Finder nach Artikelnummer aufsteigend + Anwendung

Finder by article numbers ascending + application

✓ OPTIMAL OPTIMAL ✓ GUT GOOD ✓ MÖGLICH POSSIBLE



Weichholz, Hartholz, Exotenholz, Quer	Weichholz, Hartholz, Exotenholz, Längs	Holz mit Einschlüssen wie Nägel, Klammern, Beton- und Mörtelreste	Leimholz, Tischler- und Furniersperrholz, Schichtholzplatten	Spanplatten, Hartfaserplatten, Platten ohne Belag LDF, MDF, HDF	Spanplatten, Hartfaserplatten, Kunststoff beschichtet/ furniert, MDF, HDF
Soft wood, hard wood, and exotic wood across the grain	Soft wood, hard wood, and exotic wood along the grain	Wood with inclusions like nails, clips, concrete residues	Bonded wood, blockboard and veneer plywood, laminated wood	Chipboard, hard fibre board, boards without laminate LDF, MDF, HDF	Chipboard, hard fibre board, plastic-coated/veneered, MDF, HDF

ART.	TYPE							
11.1235	Zuschnitt Vielblatt mit Räumerschneiden Rip/Multi-rip saw blade with raker teeth	655	✓	✓		✓	✓	
11.1238	Vielblatt mit Räumerschneiden Multi-rip saw blade with raker teeth	656		✓				
11.1239	Vielblatt mit Räumerschneiden Multi-rip saw blade with raker teeth	657		✓				
11.1250	Bausäge Construction saw	598	✓	✓	✓	✓	✓	
11.1260	Super-Bausäge Super construction saw	599	✓	✓	✓	✓	✓	✓
11.1300	Formatieren · Massivholz · Universal + Hundegger Panel sizing · Solid wood · Universal + Hundegger	659	✓	✓		✓	✓	✓
11.1320	Formatieren · Massivholz · Fensterprofile · Universal + Achswinkel Panel sizing · Solid wood · Window profiles · Universal + axial angle	661	✓			✓	✓	✓
11.1340	Kreissägeblatt für Mulag, Spearhead Böschungsmäher Mulag and Spearhead blades for hedging and siding	672	✓	✓				
11.1345	Kreissägeblatt für Vogesenblitz Trommelsäge SAT 4-700 Blade for Vogesenblitz cylinder barrel saw	673	✓	✓				
11.1350	Diamant (DP) Universal Kreissägeblatt Diamond (DP) universal blade	605					✓	✓
11.1370	Diamant (DP) Formatieren, Abrasiv Kreissägeblatt Diamond (DP) panel sizing, abrasive materials	627						✓
11.1400	Handkreissägeblätter + Lamello Blades for portable circular saws + Lamello	667	✓	✓		✓	✓	
11.1425	Formatieren · Massivholz Universal · Dünnschnitt Panel sizing · Solid wood universal · Thin-cut	663	✓			✓	✓	✓
11.1430	Formatieren · Harte Kunststoffe · Abrasiv · Dünnschnitt Panel-sizing · Abrasive · Thin-cut	631						
11.1450	Kapp- und Gehrungssägeblätter · Negativ Chop- and mitre saws · Negative	665	✓			✓	✓	✓
11.1460	Formatieren · Harte Kunststoffe · Platten · Abrasiv Panel sizing · Hard plastics · Boards · Abrasive	633						✓
11.1470	Formatieren · Kunststoffe · Platten Panel sizing · Plastics · Boards	635					✓	✓
11.1480	Ritzer 2-teilig Scorer 2-part	669						✓
11.1510	Plattenaufteilsägen großflächig (Formatieren) Panel sizing large-scale	615					✓	✓
11.1520	Ritzer konisch Scorer conical	615						✓
11.1530	Nut-Kreissägeblätter · 3-teilig Grooving circular saws · 3-parts	676	✓	✓		✓	✓	✓
11.1600	Formatieren · Hohlzahn · Dach-Flach · Positiv Panel sizing · Hollow tooth · Inverted V-flat tooth · Positive	637					✓	✓
11.1602	Formatieren · Hohlzahn · Dach-Flach · Negativ Panel sizing · Hollow tooth · Inverted V-flat tooth · Negative	639					✓	✓
11.1604	Formatieren · Hohlzahn · Trapez-Trapez · Positiv Panel sizing · Hollow tooth · Triple chip · Positive	641					✓	✓
11.1610	Formatieren · Wechselzahn Extrem 35° · Positiv Panel sizing · Alternate top bevel extreme 35° · Positive	643	✓			✓	✓	✓
11.1615	Formatieren · Wechselzahn Extrem 35° · Negativ Panel sizing · Alternate top bevel extreme 35° · Negative	645	✓			✓	✓	✓

KUNSTSTOFFE • PLASTIC

METALL • METAL

ABRASIV
ABRASIVE

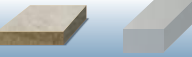
											
Furniere	Profileleisten	Mineralische/ acrylgebundene Massivplatten/ Küchenplatten: Corian®, Noblan®, Hi-Macs®, Staron®, Rausolid®, Varicor®	HPL-Duroplastische Schichtstoffplatten/ Fassadenplatten: Trespa®, Resopal®, Duropal®, Formica®, Kronospan®, Decodur®	Kunststoffe, Plexiglas, Duro- und Thermoplaste	Dünobleche, Sandwich Material, Verbundstoffe	Ne-Metall wie Alu, Messing, Kupfer	Baustahl	Edelstahl	Dünobleche, Sandwich Material, Verbundstoffe	Gips-Zement-Steinwollplatten, Eternit, GFK, CFK, HPL, Mineralwerkstoffe, Graphit	Gasbetonsteine
Veneers	Profiled wood	Minera/acrylic bound solid boards/kitchen worktops: Corian®, Noblan®, Hi-Macs®, Staron®, Rausolid®, Varicor®	HPL High-Pressure-Laminate solid boards/ façade panels: Trespa®, Resopal®, Duropal®, Formica®, Kronospan®, Decodur®	Plastics, plexiglass, acrylics, duro- and thermoplastics	Thin iron sheets, sandwich material, composites	Non ferrous materials like alu, copper, brass	Mild steel	Stainless steel	Thin iron sheets, sandwich material, composites	Gypsum/Cement fibre boards, Rockwool, Eternit, GRP, CFK, HPL, Mineral material, Graphite	Autoclaved aerated concrete blocks
										✓	✓
✓	✓	✓	✓	✓	✓					✓	✓
✓	✓	✓	✓	✓						✓	
✓	✓			✓							
			✓	✓	✓					✓	✓
			✓	✓	✓					✓	
✓	✓	✓	✓	✓						✓	
✓	✓	✓	✓	✓							
		✓	✓	✓	✓					✓	
		✓	✓	✓						✓	
		✓	✓	✓							
		✓	✓	✓							
		✓	✓	✓							
		✓	✓	✓						✓	
					✓						
					✓						
					✓						
					✓						
✓	✓				✓						
✓	✓				✓						



Art.
100
101
102

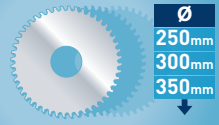

Finder nach Blatt-Ø aufsteigend + Anwendung

Finder by blade-Ø + application

✓ OPTIMAL
OPTIMAL

✓ GUT
GOOD

✓ MÖGLICH
POSSIBLE

Weichholz, Hartholz, Exotenholz, Quer	Weichholz, Hartholz, Exotenholz Längs	Holz mit Einschlüssen wie Nägel, Klammern, Beton- und Mörtelreste	Leimholz, Tischler- und Furniersperrholz, Schichtholzplatten	Spanplatten, Hartfaserplatten, Platten ohne Belag LDF, MDF, HDF	Spanplatten, Hartfaserplatten Kunststoff beschichtet/ furniert, MDF, HDF
Soft wood, hard wood, and exotic wood across the grain	Soft wood, hard wood, and exotic wood along the grain	Wood with inclusions like nails, clips, concrete residues	Bonded wood, blockboard and veneer plywood, laminated wood	Chipboard, hard fibre board, boards without laminate LDF, MDF, HDF	Chipboard, hard fibre board, plastic-coated/ veneered, MDF, HDF

					ART.	
63	1,6	16	64 BW	-	53980.063.010	674
63	1,6	16	100 BW	-	53980.063.020	674
63	1,6	16	64 BW	-	53990.063.010	674
63	1,6	16	100 BW	-	53990.063.020	674
63	1,6	16	44 BW	-	54000.063.010	674
63	1,6	16	80 BW	-	54000.063.020	674
63	1,6	16	44 BW	-	54010.063.010	674
63	1,6	16	64 BW	-	54010.063.020	674
63	1,2	16	100 BW	-	54010.063.030	674
68	1,6	16	44 BW	-	53980.068.010	674
68	1,6	16	72 BW	-	53980.068.020	674
68	1,6	16	44 BW	-	53990.068.010	674
68	1,6	16	72 BW	-	53990.068.020	674
68	1,6	16	44 BW	-	54000.068.010	674
68	1,6	16	44 BW	-	54010.068.010	674
68	1,6	16	84 BW	-	54010.068.030	674
75	2,0	16	32 BW	-	54010.075.010	674
80	2,0	16	34 BW	-	53980.080.010	674
80	2,0	16	54 BW	-	53980.080.020	674
80	2,0	16	80 BW	-	53980.080.020	674
80	2,0	16	34 BW	-	53990.080.010	674
80	2,0	16	54 BW	-	53990.080.020	674
80	2,0	16	80 BW	-	53990.080.020	674
80	2,8-3,6/2,2	20	2x10 WZ	-	111480.080.010	669
92	3,0/2,5	30	24 / 45°L	-	111150.092.010	671
92	3,0/2,5	30	24 / 45°R	-	111150.092.020	671
95	2,1/1,6	20	20 / 45°L	-	111150.095.010	671
95	2,1/1,6	20	20 / 45°R	-	111150.095.020	671
98	3,0/2,0	32	36 / 45°L	-	111150.098.010	671
98	3,0/2,0	32	36 / 45°R	-	111150.098.020	671
100	2,6/1,6	12	30 WZ	-	111400.100.010	667
100	2,6/1,6	22/20	30 WZ	LAMELLO	111400.100.020	667
100	3,97/2,8	22	6 WZ	LAMELLO	111400.100.030	667
100	3,97/2,8	22	12 WZ	LAMELLO	111400.100.040	667
100	2,8-3,6/2,2	20	2x12 WZ	-	111480.100.010	669
100	2,8-3,6/2,2	22	2x12 WZ	-	111480.100.020	669
103	2,1/1,6	32	24 / 45°	-	111150.103.010	671
103	2,1/1,6	32	24 / 45°	-	111150.103.020	671
103	2,0	32	60 / 45°L	-	111170.103.010	671
103	2,0	32	60 / 45°R	-	111170.103.020	671
105	2,6/1,6	22/20	30 WZ	-	111400.105.010	667
120	2,8/2,0	20	34 TFN	-	108000.120.010	546
120	2,0/1,4	25,4/22	14 WZ	-	108055.120.010	543
120	2,0/1,4	25,4/22	24 WZ	-	108055.120.020	543
120	2,0/1,4	25,4/22	40 WWF	-	108055.120.030	543
120	2,2/1,6	20	36 TFND	-	111120.120.010	571
120	2,4/1,4	22	24 WZ	LAMELLO	111400.120.010	667
120	1,8/1,2	20	12 WZ	-	111425.120.010	663
120	1,8/1,2	20	28 WZ	-	111425.120.020	663
120	1,8/1,2	20	44 WZ	-	111425.120.030	663
120	1,8/1,2	20	40 TFF-P	-	111430.120.010	631
120	2,8-3,6/2,2	20	2x12 WZ	-	111480.120.010	669
120	2,8-3,6/2,2	22	2x12 WZ	-	111480.120.020	669
120	2,8-3,8/2,2	22	2x12 WZ	4-4,6-39+4-4,6-55	111480.120.030	669
120	2,8-3,8/2,2	50	2x12 WZ	4-6,4-62	111480.120.040	669
125	2,6/1,6	20/12,7	24 WZ	-	111400.125.010	667

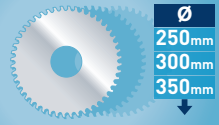

Finder nach Blatt-Ø aufsteigend + Anwendung

Finder by blade-Ø + application

✓ OPTIMAL
✓ GUT
✓ MÖGLICH

Weichholz, Hartholz, Exotenholz, Quer	Weichholz, Hartholz, Exotenholz Längs	Holz mit Einschlüssen wie Nägel, Klammern, Beton- und Mörtelreste	Leimholz, Tischler- und Furniersperrholz, Schichtholzplatten	Spanplatten, Hartfaserplatten, Platten ohne Belag LDF, MDF, HDF	Spanplatten, Kunststoff beschichtet/ furniert, MDF, HDF
Soft wood, hard wood, and exotic wood across the grain	Soft wood, hard wood, and exotic wood along the grain	Wood with inclusions like nails, clips, concrete residues	Bonded wood, blockboard and veneer plywood, laminated wood	Chipboard, hard fibre board, boards without laminate LDF, MDF, HDF	Chipboard, hard fibre board, plastic-coated/veneered, MDF, HDF

						ART.	
125	2,6/1,6	20/12,7	36 WZ	-	111400.125.020	667	✓
125	2,8-3,6/2,2	20	2x12 WZ	-	111480.125.010	669	✓
125	2,8-3,6/2,2	22	2x12 WZ	-	111480.125.020	669	✓
125	4,4-5,6/3,4	20	24 KW	-	111520.125.010	615	✓
125	3,1-4,3/2,8	22/20	24 KW	-	111520.125.020	615	✓
130	2,6/1,6	20/16	24 WZ	-	111400.130.010	667	✓
130	2,6/1,6	20/16	36 WZ	-	111400.130.020	667	✓
136	1,6/1,2	20/10	30 FF	2-6-32	107100.136.010	538	✓
136	1,6/1,2	20/10	36 FF	2-6-32	107300.136.010	540	✓
136	1,6/2,0	20/10	38 FF	2-6-32	107400.136.010	541	✓
136	2,8/2,0	20/10	40 TFN	2-6-32	108000.136.010	546	✓
136	2,0/1,4	20/10	16 WZ	-	108055.136.010	543	✓
136	2,0/1,4	20/10	30 WZ	-	108055.136.020	543	✓
136	2,0/1,4	20/10	40 WWF	-	108055.136.030	543	✓
136	2,2/1,6	20/10	40 TFND	2-6-32	111120.136.010	571	✓
136	2,6/1,6	20/10	10 TT	2-6-32	111250.136.010	598	✓
136	2,8/1,8	20/10	20 WZ	2-6-32	111260.136.010	599	✓
136	1,8/1,2	20/10	14 WZ	-	111425.136.010	663	✓
136	1,8/1,2	20/10	30 WZ	-	111425.136.020	663	✓
136	1,8/1,2	20/10	48 WZ	-	111425.136.030	663	✓
138	2,5/2,0	14	24 FL	-	111150.138.010	671	✓
138	2,5/2,0	20	24 FL	-	111150.138.020	671	✓
140	1,8/1,4	62	46 WWF	-	53950.140.010	675	✓
140	1,8/1,4	62	48 WWF	-	53950.140.020	675	✓
140	1,8/1,4	62	46 WWF	-	53960.140.010	675	✓
140	1,8/1,4	62	48 WWF	-	53960.140.020	675	✓
140	2,7/1,5	62	DIA	-	53970.140.010	675	✓
140	2,6/1,6	20	12 WZ	-	111400.140.010	667	✓
140	2,6/1,6	20	20 WZ	-	111400.140.020	667	✓
140	2,6/1,6	20	36 WZ	-	111400.140.030	667	✓
150	1,8/1,4	20/16	30 FF	2-6-32	107100.150.010	538	✓
150	2,8/2,0	20/16	42 TFN	2-6-32	108000.150.010	546	✓
150	2,4/1,6	20/16	42 TFND	2-6-32	111120.150.010	571	✓
150	3,2/2,2	30	24 WZ	UNI	111215.150.010	651	✓
150	2,8/1,6	20/16	24 WZ	2-6-32	111260.150.010	599	✓
150	3,2/2,2	30	36 WZ	UNI	111300.150.010	659	✓
150	2,6/1,6	20/16	12 WZ	2-6-32	111400.150.010	667	✓
150	2,6/1,6	20/16	24 WZ	2-6-32	111400.150.020	667	✓
150	2,6/1,6	20/16	36 WZ	2-6-32	111400.150.030	667	✓
150	2,6/1,6	20/16	48 WZ	2-6-32	111400.150.040	667	✓
150	2,6/1,6	22	24 WZ	LAMELLO	111400.150.045	667	✓
150	2,6/1,6	30	12 WZ	-	111400.150.050	667	✓
150	2,6/1,6	30	24 WZ	-	111400.150.060	667	✓
150	2,6/1,6	30	36 WZ	-	111400.150.070	667	✓
150	2,6/1,6	30	48 WZ	-	111400.150.080	667	✓
160	1,8/1,4	20/16	30 FF	2-6-32	107100.160.010	538	✓
160	1,8/1,4	20/16	40 FF	2-6-32	107300.160.010	540	✓
160	1,8/1,4	20/16	42 FF	2-6-32	107400.160.010	541	✓
160	2,8/2,0	20/16	42 TFN	2-6-32	108000.160.010	546	✓
160	2,0/1,4	20/16	18 WZ	2-6-32	108055.160.010	543	✓
160	2,0/1,4	20/16	30 WZ	2-6-32	108055.160.020	543	✓
160	2,0/1,4	20/16	40 WWF	2-6-32	108055.160.030	543	✓
160	2,4/1,8	20/16	42 TFND	2-6-32	111120.160.010	571	✓
160	2,2/1,6	20/16	60 TFND	2-6-32	111120.160.020	571	✓
160	2,4/1,8	30	42 TFND	UNI1	111120.160.030	571	✓
160	2,6/1,6	20/16	12 TT	2-6-32	111250.160.010	598	✓
160	2,8/1,6	20/16	24 WZ	2-6-32	111260.160.010	599	✓
160	2,2/1,6	20/16	4 FL	2-6-32,5	111350.160.005	605	✓

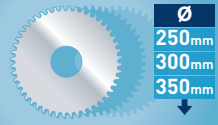

Finder nach Blatt-Ø aufsteigend + Anwendung

Finder by blade-Ø + application

✓ OPTIMAL OPTIMAL ✓ GUT GOOD ✓ MÖGLICH POSSIBLE

Weichholz, Hartholz, Exotenholz, Quer	Weichholz, Hartholz, Exotenholz Längs	Holz mit Einschlüssen wie Nägel, Klammern, Beton- und Mörtelreste	Leimholz, Tischler- und Furniersperrholz, Schichtholzplatten	Spanplatten, Hartfaserplatten, Platten ohne Belag LDF, MDF, HDF	Spanplatten, Kunststoff beschichtet/ furniert, MDF, HDF
Soft wood, hard wood, and exotic wood across the grain	Soft wood, hard wood, and exotic wood along the grain	Wood with inclusions like nails, clips, concrete residues	Bonded wood, blockboard and veneer plywood, laminated wood	Chipboard, hard fibre board, boards without laminate LDF, MDF, HDF	Chipboard, hard fibre board, plastic-coated/veneered, MDF, HDF

					ART.	
180	2,5/1,4	22	12 WZ	LAMELLO	111400.180.043	667
180	2,8/1,8	22	24 WZ	LAMELLO	111400.180.046	667
180	2,8/1,8	30	14 WZ	2-7-42	111400.180.050	667
180	2,8/1,8	30	24 WZ	2-7-42	111400.180.060	667
180	2,8/1,8	30	40 WZ	2-7-42	111400.180.070	667
180	2,8/1,8	30	56 WZ	2-7-42	111400.180.080	667
180	1,8/1,2	20/16	18 WZ	2-6-32	111425.180.010	663
180	1,8/1,2	20/16	40 WZ	2-6-32	111425.180.020	663
180	1,8/1,2	20/16	60 WZ	2-6-32	111425.180.030	663
180	1,8/1,2	20/16	76 WZ	2-6-32	111425.180.040	663
180	1,8/1,2	20/16	60 TFF-P	2-6-32	111430.180.010	631
180	4,4-5,2/3,2	45	36 K	-	111520.180.010	615
180	4,8-5,6/3,5	45	36 K	-	111520.180.020	615
180	2,8/1,8	30/20	38 HDF-P	2-7-42	111600.180.010	637
185	1,8/1,4	20/16	34 FF	2-6-32	107100.185.010	538
185	1,8/1,4	20/16	44 FF	2-6-32	107300.185.010	540
185	1,8/1,4	20/16	48 FF	2-6-32	107400.185.010	541
185	2,8/2,0	20/16	48 TFN	2-6-32	108000.185.010	546
185	2,0/1,4	20/16	20 WZ	2-6-32	108055.185.010	543
185	2,0/1,4	20/16	34 WZ	2-6-32	108055.185.020	543
185	2,0/1,4	20/16	48 WWF	2-6-32	108055.185.030	543
185	2,2/1,6	20/16	64 TFND	2-6-32	111120.185.010	571
185	2,8/1,8	20/16	12 TT	2-6-32	111250.185.010	598
185	2,8/1,8	20/16	30 WZ	2-6-32	111260.185.010	599
185	2,8/1,8	20/16	14 WZ	2-6-32	111400.185.010	667
185	2,8/1,8	20/16	24 WZ	2-6-32	111400.185.020	667
185	2,8/1,8	20/16	40 WZ	2-6-32	111400.185.030	667
185	2,8/1,8	20/16	56 WZ	2-6-32	111400.185.040	667
190	1,8/1,4	30	38 FF	UNI1	107100.190.010	538
190	1,8/1,4	30/20	48 FF	UNI1	107300.190.010	540
190	1,8/1,4	30	48 FF	UNI1	107400.190.010	541
190	2,8/2,0	30	54 TFN	UNI1	108000.190.010	546
190	2,0/1,4	30	20 WZ	UNI1	108055.190.010	543
190	2,0/1,4	30	34 WZ	UNI1	108055.190.020	543
190	2,0/1,4	30	48 WWF	UNI1	108055.190.030	543
190	2,4/1,8	30	54 TFND	UNI1	111120.190.010	571
190	2,2/1,6	30	68 TFND	UNI1	111120.190.020	571
190	2,8/1,8	30	14 TT	2-7-42	111250.190.010	598
190	2,8/1,8	30	30 WZ	2-7-42	111260.190.010	599
190	2,2/1,6	30/20	6 FL	2-7-42	111350.190.005	605
190	2,2/1,6	30/20	8 FL	2-7-42	111350.190.010	605
190	2,2/1,6	30/20	30 FL	2-7-42	111350.190.020	605
190	2,8/1,8	20/16	16 WZ	2-6-32	111400.190.010	667
190	2,8/1,8	20/16	30 WZ	2-6-32	111400.190.020	667
190	2,8/1,8	20/16	48 WZ	2-6-32	111400.190.030	667
190	2,8/1,8	20/16	60 WZ	2-6-32	111400.190.040	667
190	2,8/1,8	30	16 WZ	2-7-42	111400.190.050	667
190	2,8/1,8	30	30 WZ	2-7-42	111400.190.060	667
190	2,8/1,8	30	48 WZ	2-7-42	111400.190.070	667
190	2,8/1,8	30	60 WZ	2-7-42	111400.190.080	667
190	1,8/1,2	30/20	18 WZ	2-7-42	111425.190.010	663
190	1,8/1,2	30/20	42 WZ	2-7-42	111425.190.020	663
190	1,8/1,2	30/20	60 WZ	2-7-42	111425.190.030	663
190	1,8/1,2	30/20	76 WZ	2-7-42	111425.190.040	663
190	1,8/1,2	30/20	60 TFF-P	2-7-42	111430.190.010	631
190	2,8/1,8	30	42 HDF-P	2-7-42	111600.190.010	637
190	2,8/1,8	30	60 WZE-P	2-7-42	111610.190.010	643
200	2,0/1,6	30	40 FF	UNI1	107100.200.010	538

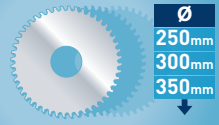

Finder nach Blatt-Ø aufsteigend + Anwendung

Finder by blade-Ø + application

✓ OPTIMAL OPTIMAL ✓ GUT GOOD ✓ MÖGLICH POSSIBLE

Weichholz, Hartholz, Exotenholz, Quer	Weichholz, Hartholz, Exotenholz Längs	Holz mit Einschlüssen wie Nägel, Klammern, Beton- und Mörtelreste	Leimholz, Tischler- und Furniersperrholz, Schichtholzplatten	Spanplatten, Hartfaserplatten, Platten ohne Belag LDF, MDF, HDF	Spanplatten, Kunststoff beschichtet/ furniert, MDF, HDF
Soft wood, hard wood, and exotic wood across the grain	Soft wood, hard wood, and exotic wood along the grain	Wood with inclusions like nails, clips, concrete residues	Bonded wood, blockboard and veneer plywood, laminated wood	Chipboard, hard fibre board, boards without laminate LDF, MDF, HDF	Chipboard, hard fibre board, plastic-coated/veneered, MDF, HDF

					ART.													
200	2,0/1,6	30	48 FF	UNI1	107300.200.010	540												
200	2,0/1,6	30	54 FF	UNI1	107400.200.010	541												
200	2,8/2,0	30	54 TFN	UNI1	108000.200.010	546	✓											
200	3,2/2,5	30	54TFP	UNI1+UNI2	111000.200.010	565				✓								
200	2,8/2,2	30	72 TFP	UNI1+UNI2	111000.200.020	565												
200	2,4/1,8	30	54 TFND	UNI1	111120.200.010	571												
200	2,2/1,6	30	68 TFND	UNI1	111120.200.020	571												
200	2,1/1,6	20	80 WZ	-	111150.200.010	671	✓											
200	2,1/1,6	20	80 WZN	-	111150.200.020	671	✓											
200	2,2/1,8	20	100 TFN	-	111150.200.030	671	✓											
200	2,1/1,6	32	80 WZ	-	111150.200.040	671	✓											
200	2,2/1,8	30	100 TFN	-	111150.200.050	671	✓											
200	2,2/1,8	32	100 TFN	-	111150.200.060	671	✓											
200	2,2/1,8	32/30	100 WZN	-	111150.200.070	671	✓											
200	2,0	32	180 HZ	2-8-45	111170.200.010	671												
200	3,2/2,2	30	36 WZ	UNI	111215.200.010	651	✓		✓		✓		✓					
200	2,8/1,8	30	30 WZ	2-7-42	111260.200.010	599	✓	✓		✓		✓		✓				✓
200	3,2/2,2	30	48 WZ	UNI	111300.200.010	659	✓	✓		✓		✓		✓				✓
200	3,0/2,2	30	65 WFA	2-6,2-42+4-6-52+4-6,6-60	111320.200.010	661	✓			✓		✓		✓				✓
200	2,4/1,6	22	12 WZ	LAMELLO	111400.200.003	667	✓	✓		✓		✓		✓				✓
200	2,4/1,6	22	24 WZ	LAMELLO	111400.200.007	667	✓	✓		✓		✓		✓				✓
200	2,8/1,8	30	18 WZ	2-7-42	111400.200.010	667	✓	✓		✓		✓		✓				✓
200	2,8/1,8	30	30 WZ	2-7-42	111400.200.020	667	✓	✓		✓		✓		✓				✓
200	2,8/1,8	30	48 WZ	2-7-42	111400.200.030	667	✓	✓		✓		✓		✓				✓
200	2,8/1,8	30	64 WZ	2-7-42	111400.200.040	667	✓	✓		✓		✓		✓				✓
200	2,0/1,4	30	18 WZ	2-7-42	111425.200.010	663	✓	✓		✓		✓		✓				✓
200	2,0/1,4	30	42 WZ	2-7-42	111425.200.020	663	✓	✓		✓		✓		✓				✓
200	2,0/1,4	30	64 WZ	2-7-42	111425.200.030	663	✓	✓		✓		✓		✓				✓
200	2,0/1,4	30	80 WZ	2-7-42	111425.200.040	663	✓	✓		✓		✓		✓				✓
200	2,0/1,4	30	64 TFF-P	2-7-42	111430.200.010	631												
200	4,4-5,2/3,2	65	36 K	2-9-110 + 2-9-100	111520.200.010	615												✓
200	4,4-5,2/3,2	30	36 KW	2-9-60	111520.200.020	615												✓
200	4,4-5,2/3,2	20	36 K	-	111520.200.030	615												✓
200	5-13 / 4-12	30	24 + 4 + 24	UNI	111530.200.010	676	✓	✓		✓		✓		✓				✓
200	2,8/1,8	30	48 HDF-P	2-7-42	111600.200.010	637												✓
200	2,8/1,8	30	64 WZE-P	2-7-42	111610.200.010	643				✓				✓				✓
210	2,0/1,6	30	40 FF	UNI1	107100.210.010	538												
210	2,0/1,6	30	54 FF	UNI1	107300.210.010	540												
210	2,0/1,6	30	54 FF	UNI1	107400.210.010	541												
210	2,8/2,0	30	54 TFN	UNI1	108000.210.010	546	✓			✓								
210	2,0/1,4	30	22 WZ	UNI1	108055.210.010	543	✓	✓		✓		✓		✓				✓
210	2,0/1,4	30	36 WZ	UNI1	108055.210.020	543	✓	✓		✓		✓		✓				✓
210	2,0/1,4	30	48 WWF	UNI1	108055.210.030	543	✓	✓		✓		✓		✓				✓
210	2,4/1,8	30	54 TFND	UNI1	111120.210.010	571												
210	2,2/1,6	30	72 TFND	UNI1	111120.210.020	571												
210	2,8/1,8	30	14 TT	2-7-42	111250.210.010	598	✓	✓		✓		✓		✓				✓
210	2,8/1,8	30	34 WZ	2-7-42	111260.210.010	599	✓	✓		✓		✓		✓				✓
210	2,2/1,6	30	12 FL	UNI	111350.210.010	605												✓
210	2,2/1,6	30	30 FL	UNI	111350.210.020	605												✓
210	2,8/1,8	30	18 WZ	2-7-42	111400.210.010	668	✓	✓		✓		✓		✓				✓
210	2,8/1,8	30	30 WZ	2-7-42	111400.210.020	668	✓	✓		✓		✓		✓				✓
210	2,8/1,8	30	48 WZ	2-7-42	111400.210.030	668	✓	✓		✓		✓		✓				✓
210	2,8/1,8	30	64 WZ	2-7-42	111400.210.040	668	✓	✓		✓		✓		✓				✓
210	2,0/1,4	30	20 WZ	2-7-42	111425.210.010	663	✓	✓		✓		✓		✓				✓
210	2,0/1,4	30	48 WZ	2-7-42	111425.210.020	663	✓	✓		✓		✓		✓				✓
210	2,0/1,4	30	64 WZ	2-7-42	111425.210.030	663	✓	✓		✓		✓		✓				✓
210	2,0/1,4	30	80 WZ	-	111425.210.040	663	✓	✓		✓		✓		✓				✓
210	2,0/1,4	30	64 TFF-P	2-7-42	111430.210.010	631												

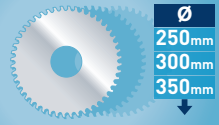

Finder nach Blatt-Ø aufsteigend + Anwendung

Finder by blade-Ø + application

✓ OPTIMAL OPTIMAL ✓ GUT GOOD ✓ MÖGLICH POSSIBLE



Weichholz, Hartholz, Exotenholz, Quer	Weichholz, Hartholz, Exotenholz Längs	Holz mit Einschlüssen wie Nägel, Klammern, Beton- und Mörtelreste	Leimholz, Tischler- und Furniersperrholz, Schichtholzplatten	Spanplatten, Hartfaserplatten, Platten ohne Belag LDF, MDF, HDF	Spanplatten, Kunststoff beschichtet/ furniert, MDF, HDF
Soft wood, hard wood, and exotic wood across the grain	Soft wood, hard wood, and exotic wood along the grain	Wood with inclusions like nails, clips, concrete residues	Bonded wood, blockboard and veneer plywood, laminated wood	Chipboard, hard fibre board, boards without laminate LDF, MDF, HDF	Chipboard, hard fibre board, plastic-coated/veneered, MDF, HDF

						ART.												
210	2,8/1,8	30	24 WZN	2-7-42	111450.210.010	665	✓	✓		✓	✓							
210	2,8/1,8	30	48 WZN	2-7-42	111450.210.020	665	✓	✓		✓	✓							
210	2,8/1,8	30	48 HDF-P	2-7-42	111600.210.010	637												
210	2,8/1,8	30	64 WZE-P	2-7-42	111610.210.010	643				✓								
216	2,0/1,6	30	42 FF	UNI1	107100.216.010	538												
216	2,0/1,6	30	54 FF	UNI1	107300.216.010	540												
216	2,0/1,6	30	54 FF	UNI1	107400.216.010	541												
216	2,8/2,0	30	60 TFN	UNI1	108000.216.010	546	✓			✓								
216	2,8/2,0	30	80 TFN	UNI1	108000.216.020	546	✓			✓								
216	2,0/1,4	30	24 WZ	UNI1	108055.216.010	543	✓	✓		✓			✓				✓	
216	2,0/1,4	30	36 WZ	UNI1	108055.216.020	543	✓			✓			✓				✓	
216	2,0/1,4	30	48 WWF	UNI1	108055.216.030	543	✓			✓			✓				✓	
216	2,4/1,8	30	60 TFND	UNI1	111120.216.010	571												
216	2,2/1,6	30	80 TFND	UNI1	111120.216.020	571												
216	2,8/1,8	30	14 TT	2-7-42	111250.216.010	598	✓			✓			✓					
216	2,8/1,8	30	34 WZ	2-7-42	111260.216.010	599	✓	✓		✓			✓					✓
216	2,2/1,6	30	12 FL	UNI	111350.216.010	605							✓					✓
216	2,2/1,6	30	30 FL	UNI	111350.216.020	605							✓					✓
216	2,0/1,4	30	20 WZ	2-7-42	111425.216.010	663	✓	✓		✓			✓					✓
216	2,0/1,4	30	48 WZ	2-7-42	111425.216.020	663	✓	✓		✓			✓					✓
216	2,0/1,4	30	64 WZ	2-7-42	111425.216.030	663	✓	✓		✓			✓					✓
216	2,0/1,4	30	80 WZ	2-7-42	111425.216.040	663	✓	✓		✓			✓					✓
216	2,8/1,8	30	24 WZN	2-7-42	111450.216.010	665	✓	✓		✓			✓					✓
216	2,8/1,8	30	48 WZN	2-7-42	111450.216.020	665	✓	✓		✓			✓					✓
216	2,8/1,8	30	60 WZN	2-7-42	111450.216.030	665	✓	✓		✓			✓					✓
216	2,8/1,8	30	80 WZN	2-7-42	111450.216.040	665	✓	✓		✓			✓					✓
216	2,8/1,8	30	48 HDF-N	2-7-42	111602.216.010	639							✓					✓
216	2,8/1,8	30	64 WZE-N	2-7-42	111615.216.010	645				✓			✓					✓
220	2,8/2,0	30	54 TFN	UNI1	108000.220.010	546	✓			✓								
220	2,4/1,8	30	64 TFND	UNI1	111120.220.010	571												
220	2,2/1,6	30	80 TFND	UNI1	111120.220.020	571												
220	3,0/2,2	30	70 WFA	UNI	111320.220.010	661	✓			✓			✓					✓
220	2,8/1,8	30	20 WZ	2-7-42	111400.220.010	668	✓	✓		✓			✓					✓
220	2,8/1,8	30	36 WZ	2-7-42	111400.220.020	668	✓	✓		✓			✓					✓
220	2,8/1,8	30	48 WZ	2-7-42	111400.220.030	668	✓	✓		✓			✓					✓
220	2,8/1,8	30	64 WZ	2-7-42	111400.220.040	668	✓	✓		✓			✓					✓
220	2,0/1,4	30	48 WZ	2-7-42	111425.220.010	663	✓	✓		✓			✓					✓
220	3,2/2,2	30	64 TFP	UNI	111470.220.010	635							✓					✓
220	3,2/2,2	30	42 HDF-P	2-7-42	111600.220.010	637							✓					✓
220	3,2/2,2	30	42 HDF-N	2-7-42	111602.220.010	639							✓					✓
220	2,9/2,0	30	48 HTT-P	2-7-42	111604.220.010	641							✓					✓
220	3,2/2,2	30	68 WZE-P	2-7-42	111610.220.010	643				✓			✓					✓
220	3,2/2,2	30	68 WZE-N	2-7-42	111615.220.010	645				✓			✓					✓
225	2,0/1,4	30	24 WZ	UNI1	108055.225.010	543	✓	✓		✓			✓					✓
225	2,0/1,4	30	36 WZ	UNI1	108055.225.020	543	✓	✓		✓			✓					✓
225	2,0/1,4	30	48 WWF	UNI1	108055.225.030	543	✓			✓			✓					✓
225	2,5/1,8	30	68 TFP	UNI1+UNI2	111000.225.010	565							✓					✓
225	2,4/1,8	30	64 TFND	UNI1	111120.225.010	571												
225	2,2/1,6	30	80 TFND	UNI1	111120.225.020	571												
225	2,8/1,8	30	34 WZ	2-7-42	111260.225.010	599	✓	✓	✓	✓			✓					✓
225	2,8/1,8	30	24 WZ	2-7-42	111400.225.010	668	✓	✓		✓			✓					✓
225	2,8/1,8	30	36 WZ	2-7-42	111400.225.020	668	✓	✓		✓			✓					✓
225	2,8/1,8	30	48 WZ	2-7-42	111400.225.030	668	✓	✓		✓			✓					✓
225	2,8/1,8	30	64 WZ	2-7-42	111400.225.040	668	✓	✓		✓			✓					✓
225	2,0/1,4	30	24 WZ	2-7-42	111425.225.010	663	✓	✓		✓			✓					✓
225	2,0/1,4	30	48 WZ	2-7-42	111425.225.020	663	✓	✓		✓			✓					✓
225	2,0/1,4	30	68 WZ	2-7-42	111425.225.030	663	✓	✓		✓			✓					✓
225	2,0/1,4	30	88 WZ	2-7-42	111425.225.040	663	✓	✓		✓			✓					✓

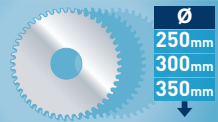

Finder nach Blatt-Ø aufsteigend + Anwendung

Finder by blade-Ø + application

✓ OPTIMAL
OPTIMAL

✓ GUT
GOOD

✓ MÖGLICH
POSSIBLE



Weichholz,
Hartholz,
Exotenholz,
Quer

Soft wood,
hard wood,
and exotic
wood across
the grain

Weichholz,
Hartholz,
Exotenholz
Längs

Soft wood,
hard wood,
and exotic
wood along the
grain

Holz mit Ein-
schlüssen wie
Nägel, Klammern,
Beton- und
Mörtelreste

Wood with
inclusions
like nails,
clips, concrete
residues

Leimholz, Tisch-
ler- und Furnier-
sperrholz,
Schichtholz-
platten

Bonded wood,
blockboard
and veneer
plywood,
laminated wood

Spanplatten,
Hartfaserplatten,
Platten ohne
Belag LDF,
MDF, HDF

Chipboard,
hard fibre board,
boards without
laminated LDF,
MDF, HDF

Spanplatten,
Kunststoff
beschichtet/
furniert, MDF, HDF

Chipboard, hard
fibre board,
plastic-coated/
veneered, MDF,
HDF

						ART.															
225	2,0/1,4	30	68 TFF-P	2-7-42	111430.225.010	631															
230	2,0/1,6	30	44 FF	UNI1	107100.230.010	538															
230	2,0/1,6	30	56 FF	UNI1	107300.230.010	540															
230	2,0/1,6	30	54 FF	UNI1	107400.230.010	541															
230	2,8/2,0	30	64 TFN	UNI1	108000.230.010	546		✓			✓										
230	2,0/1,4	30/22	24 WZ	UNI1	108055.230.010	543	✓		✓		✓		✓		✓		✓		✓		
230	2,0/1,4	30/22	36 WZ	UNI1	108055.230.020	543	✓			✓		✓		✓		✓		✓		✓	
230	2,0/1,4	30/22	48 WWF	UNI1	108055.230.030	543	✓			✓		✓		✓		✓		✓		✓	
230	2,4/1,8	30	64 TFND	UNI1	111120.230.010	571															
230	2,2/1,6	30	80 TFND	UNI1	111120.230.020	571															
230	3,2/2,2	30	24 WZ	UNI	111215.230.010	651	✓		✓		✓		✓		✓		✓		✓		
230	2,8/1,8	30	16 TT	2-7-42	111250.230.010	598	✓		✓		✓		✓		✓		✓		✓		
230	2,8/1,8	30	34 WZ	2-7-42	111260.230.010	599	✓		✓		✓		✓		✓		✓		✓		
230	3,2/2,2	30	48 WZ	UNI	111300.230.010	659	✓		✓		✓		✓		✓		✓		✓		
230	2,4/1,8	30	6 FL	UNI	111350.230.005	605															
230	2,4/1,8	30	15 FL	UNI	111350.230.010	605															
230	2,4/1,8	30	30 FL	UNI	111350.230.020	605															
230	2,8/1,8	30	24 WZ	2-7-42	111400.230.010	668	✓		✓		✓		✓		✓		✓		✓		
230	2,8/1,8	30	36 WZ	2-7-42	111400.230.020	668	✓		✓		✓		✓		✓		✓		✓		
230	2,8/1,8	30	48 WZ	2-7-42	111400.230.030	668	✓		✓		✓		✓		✓		✓		✓		
230	2,8/1,8	30	64 WZ	2-7-42	111400.230.040	668	✓		✓		✓		✓		✓		✓		✓		
230	2,0/1,4	30	24 WZ	2-7-42	111425.230.010	663	✓		✓		✓		✓		✓		✓		✓		
230	2,0/1,4	30	48 WZ	2-7-42	111425.230.020	663	✓		✓		✓		✓		✓		✓		✓		
230	2,0/1,4	30	68 WZ	2-7-42	111425.230.030	663	✓		✓		✓		✓		✓		✓		✓		
230	2,0/1,4	30	88 WZ	2-7-42	111425.230.040	663	✓		✓		✓		✓		✓		✓		✓		
230	2,0/1,4	30	68 TFF-P	2-7-42	111430.230.010	631															
230	2,8/1,8	30	68 WZE-P	2-7-42	111610.230.010	643					✓		✓		✓		✓		✓		
240	2,8/2,0	30	64 TFN	UNI1	108000.240.010	546	✓				✓										
240	2,2/1,8	30	80 TFND	UNI1	111120.240.010	571															
240	3,0/2,0	30	24 WZ	2-7-42	111400.240.010	668	✓		✓		✓		✓		✓		✓		✓		
240	3,0/2,0	30	36 WZ	2-7-42	111400.240.020	668	✓		✓		✓		✓		✓		✓		✓		
240	3,0/2,0	30	48 WZ	2-7-42	111400.240.030	668	✓		✓		✓		✓		✓		✓		✓		
250	2,0/1,75	32	54	4-9-50 / 4-11-63	107000.250.010	532															
250	2,0/1,75	32	60	4-9-50 / 4-11-63	107000.250.020	532															
250	2,0/1,75	32	72	4-9-50 / 4-11-63	107000.250.030	532															
250	2,0/1,75	32	80	4-9-50 / 4-11-63	107000.250.040	532															
250	2,0/1,75	40	54	2-8,5-55 / 4-12-64	107000.250.050	532															
250	2,0/1,75	40	60	2-8,5-55 / 4-12-64	107000.250.060	532															
250	2,0/1,75	40	72	2-8,5-55 / 4-12-64	107000.250.070	532															
250	2,0/1,75	40	80	2-8,5-55 / 4-12-64	107000.250.080	532															
250	2,0/1,75	32	54	4-9-50 / 4-11-63	107001.250.010	533															
250	2,0/1,75	32	60	4-9-50 / 4-11-63	107001.250.020	533															
250	2,0/1,75	32	72	4-9-50 / 4-11-63	107001.250.030	533															
250	2,0/1,75	32	80	4-9-50 / 4-11-63	107001.250.040	533															
250	2,0/1,75	40	54	2-8,5-55 / 4-12-64	107001.250.050	533															
250	2,0/1,75	40	60	2-8,5-55 / 4-12-64	107001.250.060	533															
250	2,0/1,75	40	72	2-8,5-55 / 4-12-64	107001.250.070	533															
250	2,0/1,75	40	80	2-8,5-55 / 4-12-64	107001.250.080	533															
250	4,0/3,5	Anfrage/On request	50 SPR	Anfrage/On request	107050.250.010	535															
250	4,0/3,5	Anfrage/On request	50 TFB	Anfrage/On request	107050.250.020	535															
250	2,2/1,8	30/25,4	48 FF	UNI1+UNI2	107100.250.010	538															
250	2,2/1,8	30/25,4	60 FF	UNI1+UNI2	107100.250.020	538															
250	2,2/1,8	30	48 TFP	UNI1+UNI2	107200.250.010	539															
250	2,2/1,8	30	60 / 3-Cut	UNI1+UNI2	107300.250.010	540															
250	2,2/1,8	30	72 FF	UNI1+UNI2	107400.250.010	541															
250	3,2/2,5	30	60 TFN	UNI1+UNI2	108000.250.010	546	✓				✓										
250	3,2/2,5	30	80 TFN	UNI1+UNI2	108000.250.020	546	✓				✓										
250	2,8/2,2	30	100 TFN	UNI1+UNI2	108000.250.030	546	✓				✓										

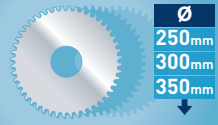

Finder nach Blatt-Ø aufsteigend + Anwendung

Finder by blade-Ø + application

✓ OPTIMAL
OPTIMAL

✓ GUT
GOOD

✓ MÖGLICH
POSSIBLE



Weichholz, Hartholz, Exotenholz, Quer	Weichholz, Hartholz, Exotenholz Längs	Holz mit Einschlüssen wie Nägel, Klammern, Beton- und Mörtelreste	Leimholz, Tischler- und Furniersperrholz, Schichtholzplatten	Spanplatten, Hartfaserplatten, Platten ohne Belag LDF, MDF, HDF	Spanplatten, Kunststoff beschichtet/ furniert, MDF, HDF
Soft wood, hard wood, and exotic wood across the grain	Soft wood, hard wood, and exotic wood along the grain	Wood with inclusions like nails, clips, concrete residues	Bonded wood, blockboard and veneer plywood, laminated wood	Chipboard, hard fibre board, boards without laminate LDF, MDF, HDF	Chipboard, hard fibre board, plastic-coated/ veneered, MDF, HDF

					ART.						
250	2,4/1,8	30/25,4	28 WZ	UNI1+UNI2	108055.250.010	543	✓	✓	✓	✓	✓
250	2,4/1,8	30/25,4	44 WZ	UNI1+UNI2	108055.250.020	543	✓		✓	✓	✓
250	2,4/1,8	30/25,4	60 WWF	UNI1+UNI2	108055.250.030	543	✓		✓	✓	✓
250	3,2/2,2	30	48 TTP	UNI	109050.250.010	563					
250	3,2/2,2	30	80 WZF	UNI	109050.250.020	563					
250	3,2/2,5	30	60 TFP	UNI1+UNI2	111000.250.010	565					
250	3,2/2,5	30	80 TFP	UNI1+UNI2	111000.250.020	565					
250	3,2/2,5	32	80 TFP	UNI2	111000.250.030	565					
250	2,4/1,8	30	100 TFPD	UNI1+UNI2	111050.250.010	567					
250	3,2/2,5	30	60 TFN	UNI1+UNI2	111100.250.010	569					
250	3,2/2,5	30	80 TFN	UNI1+UNI2	111100.250.020	569					
250	2,8/2,2	30	80 TFN	UNI1+UNI2	111100.250.030	569					
250	2,8/2,2	30	100 TFN	UNI1+UNI2	111100.250.040	569					
250	3,2/2,5	32	60 TFN	UNI2	111100.250.050	569					
250	3,2/2,5	32	80 TFN	UNI2	111100.250.060	569					
250	3,2/2,5	32	100 TFN	UNI2	111100.250.070	569					
250	2,8/2,2	30	80 TFND	UNI1+UNI2	111120.250.010	571					
250	2,2/1,8	30	100 TFND	UNI1+UNI2	111120.250.020	571					
250	2,2/1,8	32/30	120 TFND	UNI2	111120.250.030	571					
250	2,2/1,8	20	120 WZN	-	111150.250.010	671	✓				
250	3,2/2,2	30	24 WZA	UNI	111200.250.010	650	✓	✓	✓	✓	
250	3,2/2,2	30	24 WZ	UNI	111215.250.010	651	✓	✓	✓	✓	
250	3,2/2,2	30	30 WZ	UNI	111215.250.020	651	✓	✓	✓	✓	
250	3,2/2,2	30	12 FLA	UNI	111220.250.010	652	✓	✓	✓	✓	
250	3,6/2,2	30	12 FLA	UNI	111230.250.010	653	✓	✓	✓	✓	
250	3,6/2,2	30	16 WZA	UNI	111230.250.020	653	✓	✓	✓	✓	
250	3,2/2,2	30	18 FZ+R	UNI	111232.250.010	654	✓	✓	✓	✓	
250	3,2/2,2	Ø=70 / =13x5 / =20x6,5	16 FZ+R	-	111238.250.010	656	✓	✓	✓	✓	
250	3,2/2,2	Ø=80 / =14x5 / =22x6,5	16 FZ+R	-	111238.250.020	656	✓	✓	✓	✓	
250	3,6/2,5	Ø=70 / =13x5 / =20x6,5	16 FZ+R	-	111239.250.010	657	✓	✓	✓	✓	
250	3,6/2,5	Ø=80 / =14x5 / =22x6,5	16 FZ+R	-	111239.250.020	657	✓	✓	✓	✓	
250	3,2/2,2	30	20 TT	UNI	111250.250.010	598	✓	✓	✓	✓	
250	3,0/2,0	30	42 WZ	UNI	111260.250.010	599	✓	✓	✓	✓	✓
250	3,2/2,2	30	40 WZ	UNI	111300.250.010	659	✓	✓	✓	✓	✓
250	3,2/2,2	30	48 WZ	UNI	111300.250.020	659	✓	✓	✓	✓	✓
250	3,2/2,2	30	60 WZ	UNI	111300.250.030	659	✓	✓	✓	✓	✓
250	3,2/2,2	30	80 WZ	UNI	111300.250.040	659	✓	✓	✓	✓	✓
250	3,0/2,2	30	80 WFA	UNI	111320.250.010	661	✓		✓	✓	✓
250	2,4/1,8	30	6 FL	UNI	111350.250.005	605			✓	✓	✓
250	2,4/1,8	30	16 FL	UNI	111350.250.010	605			✓	✓	✓
250	2,4/1,8	30	40 FL	UNI	111350.250.020	605			✓	✓	✓
250	3,2/2,2	30	60 TFF-P	UNI	111370.250.010	627			✓	✓	✓
250	3,2/2,2	30	80 TFF-P	UNI	111370.250.020	627			✓	✓	✓
250	2,2/1,6	30	30 WZ	UNI	111425.250.010	663	✓	✓	✓	✓	✓
250	2,2/1,6	30	56 WZ	UNI	111425.250.020	663	✓	✓	✓	✓	✓
250	2,2/1,6	30	80 WZ	UNI	111425.250.030	663	✓	✓	✓	✓	✓
250	2,2/1,6	30	100 WZ	UNI	111425.250.040	663	✓	✓	✓	✓	✓
250	2,4/1,8	30	80 TFF-P	UNI	111430.250.010	631			✓	✓	✓
250	3,2/2,2	30	24 WZN	UNI	111450.250.010	665	✓	✓	✓	✓	✓
250	3,2/2,2	30	40 WZN	UNI	111450.250.020	665	✓	✓	✓	✓	✓
250	3,2/2,2	30	60 WZN	UNI	111450.250.030	665	✓	✓	✓	✓	✓
250	3,2/2,2	30	80 WZN	UNI	111450.250.040	665	✓	✓	✓	✓	✓
250	3,2/2,2	30	60 TFF-P	UNI	111460.250.010	633			✓	✓	✓
250	3,2/2,2	30	80 TFF-P	UNI	111460.250.020	633			✓	✓	✓
250	3,2/2,2	30	60 TFP	UNI	111470.250.010	635			✓	✓	✓
250	3,2/2,2	30	80 TFP	UNI	111470.250.020	635			✓	✓	✓
250	5-13 / 4-12	30	30 + 5 + 30	UNI	111530.250.010	676	✓	✓	✓	✓	✓
250	3,2/2,2	30	48 HDF-P	UNI	111600.250.010	637			✓	✓	✓

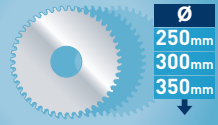

Finder nach Blatt-Ø aufsteigend + Anwendung

Finder by blade-Ø + application

✓ OPTIMAL
OPTIMAL

✓ GUT
GOOD

✓ MÖGLICH
POSSIBLE

Weichholz, Hartholz, Exotenholz, Quer	Weichholz, Hartholz, Exotenholz Längs	Holz mit Einschlüssen wie Nägel, Klammern, Beton- und Mörtelreste	Leimholz, Tischler- und Furniersperrholz, Schichtholzplatten	Spanplatten, Hartfaserplatten, Platten ohne Belag LDF, MDF, HDF	Spanplatten, Kunststoff beschichtet/ furniert, MDF, HDF
Soft wood, hard wood, and exotic wood across the grain	Soft wood, hard wood, and exotic wood along the grain	Wood with inclusions like nails, clips, concrete residues	Bonded wood, blockboard and veneer plywood, laminated wood	Chipboard, hard fibre board, boards without laminate LDF, MDF, HDF	Chipboard, hard fibre board, plastic-coated/veneered, MDF, HDF

						ART.															
250	3,2/2,2	30	48 HDF-N	UNI	111602.250.010	639															
250	2,9/2,0	30	60 HTT-P	UNI	111604.250.010	641															
250	3,2/2,2	30	80 WZE-P	UNI	111610.250.010	643															
250	3,2/2,2	30	80 WZE-N	UNI	111615.250.010	645															
255	2,2/1,8	25,4	48 TFP	-	107200.255.010	539															
255	2,2/1,8	25,4	60 / 3-Cut	-	107300.255.010	540															
255	2,2/1,8	25,4	72 FF	-	107400.255.010	541															
255	3,2/2,2	30	24 WZ	UNI	111215.255.010	651	✓														
255	3,0/2,0	30	36 WZ	UNI	111400.255.010	668	✓														
255	3,0/2,0	30	48 WZ	UNI	111400.255.020	668	✓														
255	3,0/2,0	30	64 WZ	UNI	111400.255.030	668	✓														
255	3,0/2,0	30	80 WZ	UNI	111400.255.040	668	✓														
260	2,2/1,8	30	60 FF	UNI1+UNI2	107100.260.010	538															
260	2,2/1,8	30	72 / 3-Cut	UNI1+UNI2	107300.260.010	540															
260	2,2/1,8	30	72 FF	UNI1+UNI2	107400.260.010	541															
260	3,2/2,5	30	80 TFN	UNI1+UNI2	108000.260.010	546	✓														
260	2,4/1,8	30	28 WZ	UNI1+UNI2	108055.260.010	543	✓														
260	2,4/1,8	30	44 WZ	UNI1+UNI2	108055.260.020	543	✓														
260	2,4/1,8	30	60 WWF	UNI1+UNI2	108055.260.030	543	✓														
260	2,4/1,8	30	68 TFND	UNI1+UNI2	111120.260.010	571															
260	2,4/1,8	30	100 TFND	UNI1+UNI2	111120.260.020	571															
260	3,0/2,0	30	42 WZ	UNI	111260.260.010	599	✓														
260	3,2/2,2	30	24 WZ	UNI	111400.260.010	668	✓														
260	3,2/2,2	30	48 WZ	UNI	111400.260.020	668	✓														
260	3,2/2,2	30	64 WZ	UNI	111400.260.030	668	✓														
260	2,2/1,6	30	30 WZ	UNI	111425.260.010	663	✓														
260	2,2/1,6	30	56 WZ	UNI	111425.260.020	663	✓														
260	2,2/1,6	30	80 WZ	UNI	111425.260.030	663	✓														
260	2,5/1,8	30	48 WZN	UNI	111450.260.010	665	✓														
260	2,5/1,8	30	60 WZN	UNI	111450.260.020	665	✓														
260	2,5/1,8	30	80 WZN	UNI	111450.260.030	665	✓														
270	2,2/1,8	30	60 FF	UNI1+UNI2	107100.270.010	538															
270	2,2/1,8	30	68 TF	UNI1+UNI2	107300.270.005	540															
270	2,2/1,8	30	72 / 3-Cut	UNI1+UNI2	107300.270.010	540															
270	2,2/1,8	30	72 FF	UNI1+UNI2	107400.270.010	541															
270	3,2/2,5	30	88 TFN	UNI1+UNI2	108000.270.010	546	✓														
270	2,4/1,8	30	30 WZ	UNI1+UNI2	108055.270.010	543	✓														
270	2,4/1,8	30	46 WZ	UNI1+UNI2	108055.270.020	543	✓														
270	2,4/1,8	30	60 WWF	UNI1+UNI2	108055.270.030	543	✓														
270	2,4/1,8	30	80 TFND	UNI1+UNI2	111120.270.010	571															
270	2,4/1,8	30	100 TFND	UNI1+UNI2	111120.270.020	571															
270	3,0/2,0	30	42 WZ	UNI	111260.270.010	599	✓														
270	3,2/2,2	30	24 WZ	UNI	111400.270.010	668	✓														
270	3,2/2,2	30	48 WZ	UNI	111400.270.020	668	✓														
270	3,2/2,2	30	80 WZ	UNI	111400.270.030	668	✓														
270	2,2/1,6	30	30 WZ	UNI	111425.270.010	663	✓														
270	2,2/1,6	30	56 WZ	UNI	111425.270.020	663	✓														
270	2,2/1,6	30	80 WZ	UNI	111425.270.030	663	✓														
275	3,2/2,5	40	72 TFP	2-9-55+4-12-64	111000.275.010	565															
275	3,2/2,5	40	88 TFN	2-9-55+4-12-64	111100.275.010	569															
275	3,2/2,5	40	110 TFN	2-9-55+4-12-64	111100.275.020	569															
280	2,2/1,8	30	60 FF	UNI1+UNI2	107100.280.010	538															
280	3,2/2,5	30	88 TFN	UNI1+UNI2	108000.280.010	546	✓														
280	2,4/1,8	30	32 WZ	UNI1+UNI2	108055.280.010	543	✓														
280	2,4/1,8	30	48 WZ	UNI1+UNI2	108055.280.020	543	✓														
280	2,4/1,8	30	60 WWF	UNI1+UNI2	108055.280.030	543	✓														
280	3,2/2,5	30	68 TFP	UNI1+UNI2	111000.280.010	565															
280	3,2/2,5	30	96 TFP	UNI1+UNI2	111000.280.020	565															

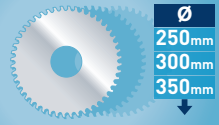

Finder nach Blatt-Ø aufsteigend + Anwendung

Finder by blade-Ø + application

✓ OPTIMAL
OPTIMAL

✓ GUT
GOOD

✓ MÖGLICH
POSSIBLE

Weichholz, Hartholz, Exotenholz, Quer	Weichholz, Hartholz, Exotenholz Längs	Holz mit Einschlüssen wie Nägel, Klammern, Beton- und Mörtelreste	Leimholz, Tischler- und Furniersperrholz, Schichtholzplatten	Spanplatten, Hartfaserplatten, Platten ohne Belag LDF, MDF, HDF	Spanplatten, Kunststoff beschichtet/ furniert, MDF, HDF
Soft wood, hard wood, and exotic wood across the grain	Soft wood, hard wood, and exotic wood along the grain	Wood with inclusions like nails, clips, concrete residues	Bonded wood, blockboard and veneer plywood, laminated wood	Chipboard, hard fibre board, boards without laminate LDF, MDF, HDF	Chipboard, hard fibre board, plastic-coated/veneered, MDF, HDF

					ART.	
280	3,2/2,5	30	88 TFN	UNI1+UNI2	111100.280.010	569
280	3,2/2,2	30	28 WZA	UNI	111200.280.010	650
280	3,2/2,2	30	48 WZ	UNI	111400.280.010	668
280	3,2/2,2	30	64 WZ	UNI	111400.280.020	668
285	2,0/1,75	32	54	4-9-50 / 4-11-63	107000.285.010	532
285	2,0/1,75	32	60	4-9-50 / 4-11-63	107000.285.020	532
285	2,0/1,75	32	72	4-9-50 / 4-11-63	107000.285.030	532
285	2,0/1,75	32	80	4-9-50 / 4-11-63	107000.285.040	532
285	2,0/1,75	40	54	4-12-64 / 4-11-80	107000.285.050	532
285	2,0/1,75	40	60	4-12-64 / 4-11-80	107000.285.060	532
285	2,0/1,75	40	72	4-12-64 / 4-11-80	107000.285.070	532
285	2,0/1,75	40	80	4-12-64 / 4-11-80	107000.285.080	532
285	2,0/1,75	32	54	4-9-50 / 4-11-63	107001.285.010	533
285	2,0/1,75	32	60	4-9-50 / 4-11-63	107001.285.020	533
285	2,0/1,75	32	72	4-9-50 / 4-11-63	107001.285.030	533
285	2,0/1,75	32	80	4-9-50 / 4-11-63	107001.285.040	533
285	2,0/1,75	40	54	4-12-64 / 4-11-80	107001.285.050	533
285	2,0/1,75	40	60	4-12-64 / 4-11-80	107001.285.060	533
285	2,0/1,75	40	72	4-12-64 / 4-11-80	107001.285.070	533
285	2,0/1,75	40	80	4-12-64 / 4-11-80	107001.285.080	533
300	2,2/1,8	30	60 FF	UNI1+UNI2	107100.300.010	538
300	2,2/1,8	30	80 FF	UNI1+UNI2	107100.300.020	538
300	2,2/1,8	30	60 TFP	UNI1+UNI2	107200.300.010	539
300	2,2/1,8	30	72 / 3-Cut	UNI1+UNI2	107300.300.010	540
300	2,2/1,8	30	84 FF	UNI1+UNI2	107400.300.010	541
300	3,2/2,5	30	72 TFN	UNI1+UNI2	108000.300.010	546
300	3,2/2,5	30	96 TFN	UNI1+UNI2	108000.300.020	546
300	2,8/2,2	30	120 TFN	UNI1+UNI2	108000.300.030	546
300	2,4/1,8	30	32 WZ	UNI1+UNI2	108055.300.010	543
300	2,4/1,8	30	48 WZ	UNI1+UNI2	108055.300.020	543
300	2,4/1,8	30	60 WWF	UNI1+UNI2	108055.300.030	543
300	3,2/2,2	30	60 TTP	UNI	109050.300.010	563
300	3,2/2,2	30	96 WZF	UNI	109050.300.020	563
300	3,2/2,5	30	72 TFP	UNI1+UNI2	111000.300.010	565
300	3,2/2,5	30	96 TFP	UNI1+UNI2	111000.300.020	565
300	3,2/2,5	32	72 TFP	UNI2	111000.300.030	565
300	3,2/2,5	32	96 TFP	UNI2	111000.300.040	565
300	3,2/2,5	40	96 TFP	2-9-55+4-12-64	111000.300.050	565
300	2,4/1,8	30	120 TFPD	UNI1+UNI2	111050.300.010	567
300	3,2/2,5	30	72 TFN	UNI1+UNI2	111100.300.010	569
300	3,2/2,5	30	96 TFN	UNI1+UNI2	111100.300.020	569
300	2,8/2,2	30	120 TFN	UNI1+UNI2	111100.300.030	569
300	3,2/2,5	32	72 TFN	UNI2	111100.300.040	569
300	3,2/2,5	32	96 TFN	UNI2	111100.300.050	569
300	2,8/2,2	32	120 TFN	UNI2	111100.300.060	569
300	3,2/2,5	40	72 TFN	2-9-55+4-12-64	111100.300.070	569
300	3,2/2,5	40	96 TFN	2-9-55+4-12-64	111100.300.080	569
300	2,4/1,8	30	120 TFND	UNI1+UNI2	111120.300.010	571
300	3,2/2,2	30	28 WZA	UNI	111200.300.010	650
300	3,2/2,2	30	24 WZ	UNI	111215.300.010	651
300	3,2/2,2	30	36 WZ	UNI	111215.300.020	651
300	3,2/2,2	30	14 FLA	UNI	111220.300.010	652
300	3,2/2,2	30	20 FLA	UNI	111220.300.020	652
300	3,8/2,2	30	14 FLA	UNI	111230.300.010	653
300	3,8/2,2	30	18 WZA	UNI	111230.300.020	653
300	3,2/2,2	30	18 FZ+R	UNI	111232.300.010	654
300	3,6/2,5	30	18 WZ+R	UNI	111232.300.020	654
300	3,4/2,2	30	24 WZ+R	UNI	111235.300.010	655

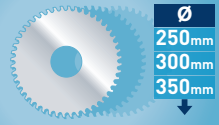

Finder nach Blatt-Ø aufsteigend + Anwendung

Finder by blade-Ø + application

✓ OPTIMAL
OPTIMAL

✓ GUT
GOOD

✓ MÖGLICH
POSSIBLE

Weichholz, Hartholz, Exotenholz, Quer	Weichholz, Hartholz, Exotenholz Längs	Holz mit Einschlüssen wie Nägel, Klammern, Beton- und Mörtelreste	Leimholz, Tischler- und Furniersperrholz, Schichtholzplatten	Spanplatten, Hartfaserplatten, Platten ohne Belag LDF, MDF, HDF	Spanplatten, Hartfaserplatten Kunststoff beschichtet/ furniert, MDF, HDF
Soft wood, hard wood, and exotic wood across the grain	Soft wood, hard wood, and exotic wood along the grain	Wood with inclusions like nails, clips, concrete residues	Bonded wood, blockboard and veneer plywood, laminated wood	Chipboard, hard fibre board, boards without laminate LDF, MDF, HDF	Chipboard, hard fibre board, plastic-coated/veneered, MDF, HDF

						ART.	
300	3,2/2,2	Ø=70 / =13x5 / =20x6,5	18 FZ+R	-	111238.300.010	656	
300	3,2/2,2	Ø=80 / =14x5 / =22x6,5	18 FZ+R	-	111238.300.020	656	
300	3,2/2,2	Ø=30,UNI	24 FZ+R	-	111238.300.030	656	
300	4,0/2,8	Ø=70 / =13x5 / =20x6,5	18 FZ+R	-	111239.300.010	657	
300	4,0/2,8	Ø=80 / =14x5 / =22x6,5	18 FZ+R	-	111239.300.020	657	
300	3,2/2,2	30	24 FWF	UNI	111250.300.010	598	
300	3,2/2,2	30	48 WZ	UNI	111260.300.010	599	
300	3,2/2,2	30	48 WZ	UNI	111300.300.010	659	
300	3,2/2,2	30	60 WZ	UNI	111300.300.020	659	
300	3,2/2,2	30	72 WZ	UNI	111300.300.030	659	
300	3,2/2,2	30	96 WZ	UNI	111300.300.040	659	
300	2,2/1,6	30	8 FL	UNI	111350.300.005	605	
300	2,2/1,6	30	30 FL	UNI	111350.300.010	605	
300	2,6/2,0	30	36 FL	UNI	111350.300.020	605	
300	2,6/2,0	30	48 FL	UNI	111350.300.030	605	
300	2,6/2,0	30	60 FL	UNI	111350.300.040	605	
300	3,2/2,2	30	72 TFF-P	UNI	111370.300.010	627	
300	3,2/2,2	30	96 TFF-P	UNI	111370.300.020	627	
300	2,2/1,6	30	36 WZ	UNI	111425.300.010	663	
300	2,2/1,6	30	60 WZ	UNI	111425.300.020	663	
300	2,2/1,6	30	96 WZ	UNI	111425.300.030	663	
300	2,2/1,6	30	120 WZ	UNI	111425.300.040	663	
300	2,4/1,8	30	96 TFF-P	UNI	111430.300.010	631	
300	3,2/2,2	30	72 WZN	UNI	111450.300.010	665	
300	3,2/2,2	30	72 TFF-P	UNI	111460.300.010	633	
300	3,2/2,2	30	96 TFF-P	UNI	111460.300.020	633	
300	3,2/2,2	30	72 TFP	UNI	111470.300.010	635	
300	3,2/2,2	30	96 TFP	UNI	111470.300.020	635	
300	4,4/3,0	30	60 TFP	2-10-60	111510.300.010	615	
300	3,2/2,2	30	72 HDF-P	UNI	111600.300.010	637	
300	3,2/2,2	30	96 WZE-P	UNI	111610.300.010	643	
300	3,2/2,2	30	96 WZE-N	UNI	111615.300.010	645	
303	3,0/2,2	30	100 WFA	UNI	111320.303.010	661	
303	3,2/2,2	30	60 TFF-P	UNI	111370.303.010	627	
303	3,2/2,2	30	72 TFF-P	UNI	111370.303.020	627	
303	3,2/2,2	30	96 TFF-P	UNI	111370.303.030	627	
303	3,2/2,2	30	60 TFF-P	UNI	111460.303.010	633	
303	3,2/2,2	30	72 TFF-P	UNI	111460.303.020	633	
303	3,2/2,2	30	96 TFF-P	UNI	111460.303.030	633	
303	3,2/2,2	30	60 TFP	UNI	111470.303.010	635	
303	3,2/2,2	30	72 TFP	UNI	111470.303.020	635	
303	3,2/2,2	30	96 TFP	UNI	111470.303.030	635	
303	3,2/2,2	30	40 HDF-P	UNI	111600.303.010	637	
303	3,2/2,2	30	60 HDF-P	UNI	111600.303.020	637	
303	3,2/2,2	30	72 HDF-P	UNI	111600.303.030	637	
303	3,2/2,2	30	60 HDF-N	UNI	111602.303.010	639	
303	3,2/2,2	30	72 HDF-N	UNI	111602.303.020	639	
303	2,9/2,0	30	72 HTT-P	UNI	111604.303.010	641	
303	3,2/2,2	30	96 WZE-P	UNI	111610.303.010	643	
303	3,2/2,2	30	96 WZE-N	UNI	111615.303.010	645	
305	2,2/1,8	25,4	60 FF	-	107100.305.010	538	
305	2,2/1,8	25,4	80 FF	-	107100.305.020	538	
305	2,2/1,8	25,4	60 TFP	-	107200.305.010	539	
305	2,2/1,8	25,4	72 / 3-Cut	-	107300.305.010	540	
305	2,2/1,8	25,4	84 FF	-	107400.305.010	541	
305	2,4/1,8	30/25,4	32 WZ	UNI1+UNI2	108055.305.010	543	
305	2,4/1,8	30/25,4	48 WZ	UNI1+UNI2	108055.305.020	543	
305	2,4/1,8	30/25,4	60 WWF	UNI1+UNI2	108055.305.030	543	

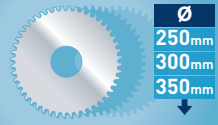

Finder nach Blatt-Ø aufsteigend + Anwendung

Finder by blade-Ø + application

✓ OPTIMAL
OPTIMAL

✓ GUT
GOOD

✓ MÖGLICH
POSSIBLE

Weichholz, Hartholz, Exotenholz, Quer	Weichholz, Hartholz, Exotenholz Längs	Holz mit Einschlüssen wie Nägel, Klammern, Beton- und Mörtelreste	Leimholz, Tischler- und Furniersperrholz, Schichtholzplatten	Spanplatten, Hartfaserplatten, Platten ohne Belag LDF, MDF, HDF	Spanplatten, Kunststoff beschichtet/ furniert, MDF, HDF
Soft wood, hard wood, and exotic wood across the grain	Soft wood, hard wood, and exotic wood along the grain	Wood with inclusions like nails, clips, concrete residues	Bonded wood, blockboard and veneer plywood, laminated wood	Chipboard, hard fibre board, boards without laminate LDF, MDF, HDF	Chipboard, hard fibre board, plastic-coated/veneered, MDF, HDF

					ART.										
305	3,2/2,5	30	96 TFN	UNI1+UNI2	111100.305.010	569									
305	2,6/2,0	30	80 TFND	UNI1+UNI2	111120.305.010	571									
305	2,4/1,8	30	120 TFND	UNI1+UNI2	111120.305.020	571									
305	3,2/2,2	30	48 WZ	UNI	111300.305.010	659	✓	✓		✓	✓		✓		
305	3,2/2,2	30	60 WZ	UNI	111300.305.020	659	✓	✓		✓	✓		✓		
305	3,2/2,2	30	72 WZ	UNI	111300.305.030	659	✓	✓		✓	✓		✓		
305	2,6/1,8	30	32 WZN	UNI	111450.305.010	665	✓	✓		✓	✓		✓		
305	2,6/1,8	30	48 WZN	UNI	111450.305.020	665	✓	✓		✓	✓		✓		
305	2,6/1,8	30	60 WZN	UNI	111450.305.030	665	✓	✓		✓	✓		✓		
305	2,6/1,8	30	72 WZN	UNI	111450.305.040	665	✓	✓		✓	✓		✓		
305	2,6/1,8	30	96 WZN	UNI	111450.305.050	665	✓	✓		✓	✓		✓		
305	2,6/1,8	30	100 WZN	UNI	111450.305.060	665	✓	✓		✓	✓		✓		
315	2,25/2,0	32	60	4-9-50	107000.315.010	532									
315	2,25/2,0	32	72	4-9-50	107000.315.020	532									
315	2,25/2,0	32	80	4-9-50	107000.315.030	532									
315	2,25/2,0	40	80	2-15-80	107000.315.040	532									
315	2,25/2,0	32	60	4-9-50	107001.315.010	533									
315	2,25/2,0	32	72	4-9-50	107001.315.020	533									
315	2,25/2,0	32	80	4-9-50	107001.315.030	533									
315	2,25/2,0	40	80	2-15-80	107001.315.040	533									
315	4,0/3,5	Anfrage/On request	60 SPR	Anfrage/On request	107050.315.010	535									
315	4,0/3,5	Anfrage/On request	60 TFB	Anfrage/On request	107050.315.020	535									
315	3,2/2,2	30	28 WZA	UNI	111200.315.010	650	✓	✓		✓	✓		✓		
315	3,2/2,2	30	24 WZ	UNI	111215.315.010	651	✓	✓		✓	✓		✓		
315	3,2/2,2	30	36 WZ	UNI	111215.315.020	651	✓	✓		✓	✓		✓		
315	3,2/2,2	30	20 FLA	2-7-42	111220.315.010	652	✓	✓		✓	✓		✓		
315	3,2/2,2	Ø=70 / =13x5 / =20x6,5	18 FZ+R	-	111238.315.010	656									
315	3,2/2,2	Ø=80 / =14x5 / =22x6,5	18 FZ+R	-	111238.315.020	656									
315	3,2/2,2	30	24 FWF	UNI	111250.315.010	598	✓	✓	✓	✓	✓		✓		
315	3,2/2,2	30	48 WZ	UNI	111260.315.010	599	✓	✓	✓	✓	✓		✓		
315	3,2/2,2	30	48 WZ	UNI	111300.315.010	659	✓	✓		✓	✓		✓		
315	3,2/2,2	30	60 WZ	UNI	111300.315.020	659	✓	✓		✓	✓		✓		
315	3,2/2,2	30	72 WZ	UNI	111300.315.030	659	✓	✓		✓	✓		✓		
315	3,2/2,2	30	96 WZ	UNI	111300.315.040	659	✓	✓		✓	✓		✓		
320	2,2/1,8	30/25,4	84 FF	UNI1+UNI2	107100.320.010	538									
320	2,2/1,8	30/25,4	84 / 3-Cut	UNI1+UNI2	107300.320.010	540									
320	2,2/1,8	30/25,4	96 FF	UNI1+UNI2	107400.320.010	541									
320	2,4/1,8	30/25,4	32 WZ	UNI1+UNI2	108055.320.010	543	✓	✓	✓	✓	✓		✓		
320	2,4/1,8	30/25,4	48 WZ	UNI1+UNI2	108055.320.020	543	✓	✓	✓	✓	✓		✓		
320	2,4/1,8	30/25,4	60 WWF	UNI1+UNI2	108055.320.030	543	✓	✓	✓	✓	✓		✓		
320	3,2/2,5	30	84 TFP	UNI1+UNI2	111000.320.010	565									
320	4,4/3,2	65	60 TFP	2-9-110	111510.320.010	615							✓		✓
330	2,2/1,8	32/30	84 FF	UNI2	107100.330.010	538									
330	2,2/1,8	32/30	84 / 3-Cut	UNI2	107300.330.010	540									
330	2,2/1,8	32/30	96 FF	UNI2	107400.330.010	541									
330	2,6/2,0	32/30	36 WZ	UNI2	108055.330.010	543	✓	✓	✓	✓	✓		✓		
330	2,6/2,0	32/30	54 WZ	UNI2	108055.330.020	543	✓	✓	✓	✓	✓		✓		
330	2,6/2,0	32/30	72 WWF	UNI2	108055.330.030	543	✓	✓	✓	✓	✓		✓		
330	3,2/2,5	32/30	72 TFP	UNI2	111000.330.010	565									
330	3,2/2,5	32/30	96 TFP	UNI2	111000.330.020	565									
330	3,2/2,5	30	72 TFN	UNI1+UNI2	111100.330.010	569									
330	3,2/2,5	30	96 TFN	UNI1+UNI2	111100.330.020	569									
330	2,8/2,2	30	120 TFN	UNI1+UNI2	111100.330.030	569									
330	3,2/2,5	32	72 TFN	UNI2	111100.330.040	569									
330	3,2/2,5	32	96 TFN	UNI2	111100.330.050	569									
330	2,8/2,2	32	120 TFN	UNI2	111100.330.060	569									
330	2,4/1,8	30	96 TFND	UNI1+UNI2	111120.330.010	571									
330	2,4/1,8	30	120 TFND	UNI1+UNI2	111120.330.020	571									

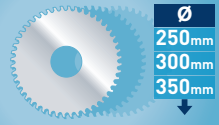

Finder nach Blatt-Ø aufsteigend + Anwendung

Finder by blade-Ø + application

✓ OPTIMAL
OPTIMAL

✓ GUT
GOOD

✓ MÖGLICH
POSSIBLE

Weichholz, Hartholz, Exotenholz, Quer	Weichholz, Hartholz, Exotenholz Längs	Holz mit Einschlüssen wie Nägel, Klammern, Beton- und Mörtelreste	Leimholz, Tischler- und Furniersperrholz, Schichtholzplatten	Spanplatten, Hartfaserplatten, Platten ohne Belag LDF, MDF, HDF	Spanplatten, Kunststoff beschichtet/ furniert, MDF, HDF
Soft wood, hard wood, and exotic wood across the grain	Soft wood, hard wood, and exotic wood along the grain	Wood with inclusions like nails, clips, concrete residues	Bonded wood, blockboard and veneer plywood, laminated wood	Chipboard, hard fibre board, boards without laminate LDF, MDF, HDF	Chipboard, hard fibre board, plastic-coated/veneered, MDF, HDF

					ART.															
350	3,5/2,5	30	28 FWF	UNI	111250.350.010	598	✓	✓	✓	✓	✓	✓	✓	✓	✓	✓	✓	✓	✓	✓
350	3,2/2,2	30	54 WZ	UNI	111260.350.010	599	✓	✓	✓	✓	✓	✓	✓	✓	✓	✓	✓	✓	✓	✓
350	3,5/2,5	30	54 WZ	UNI	111300.350.010	659	✓	✓	✓	✓	✓	✓	✓	✓	✓	✓	✓	✓	✓	✓
350	3,5/2,5	30	72 WZ	UNI	111300.350.020	659	✓	✓	✓	✓	✓	✓	✓	✓	✓	✓	✓	✓	✓	✓
350	3,5/2,5	30	84 WZ	UNI	111300.350.030	659	✓	✓	✓	✓	✓	✓	✓	✓	✓	✓	✓	✓	✓	✓
350	3,5/2,5	30	108 WZ	UNI	111300.350.040	659	✓	✓	✓	✓	✓	✓	✓	✓	✓	✓	✓	✓	✓	✓
350	3,0/2,2	30	100 WFA	UNI	111320.350.010	661	✓	✓	✓	✓	✓	✓	✓	✓	✓	✓	✓	✓	✓	✓
350	2,8/2,2	30	60 FL	UNI	111350.350.010	605	✓	✓	✓	✓	✓	✓	✓	✓	✓	✓	✓	✓	✓	✓
350	3,2/2,2	30	84 TFF-P	UNI	111370.350.010	627	✓	✓	✓	✓	✓	✓	✓	✓	✓	✓	✓	✓	✓	✓
350	3,2/2,2	30	108 TFF-P	UNI	111370.350.020	627	✓	✓	✓	✓	✓	✓	✓	✓	✓	✓	✓	✓	✓	✓
350	2,4/1,8	30	42 WZ	UNI	111425.350.010	663	✓	✓	✓	✓	✓	✓	✓	✓	✓	✓	✓	✓	✓	✓
350	2,4/1,8	30	72 WZ	UNI	111425.350.020	663	✓	✓	✓	✓	✓	✓	✓	✓	✓	✓	✓	✓	✓	✓
350	2,4/1,8	30	108 WZ	UNI	111425.350.030	663	✓	✓	✓	✓	✓	✓	✓	✓	✓	✓	✓	✓	✓	✓
350	2,4/1,8	30	140 WZ	UNI	111425.350.040	663	✓	✓	✓	✓	✓	✓	✓	✓	✓	✓	✓	✓	✓	✓
350	2,4/1,8	30	108 TFF-P	UNI	111430.350.010	631	✓	✓	✓	✓	✓	✓	✓	✓	✓	✓	✓	✓	✓	✓
350	4,4/2,8	30	42 WZN	UNI	111450.350.010	665	✓	✓	✓	✓	✓	✓	✓	✓	✓	✓	✓	✓	✓	✓
350	3,2/2,2	30	84 TFF-P	UNI	111460.350.010	633	✓	✓	✓	✓	✓	✓	✓	✓	✓	✓	✓	✓	✓	✓
350	3,2/2,2	30	108 TFF-P	UNI	111460.350.020	633	✓	✓	✓	✓	✓	✓	✓	✓	✓	✓	✓	✓	✓	✓
350	3,5/2,5	30	84 TFP	UNI	111470.350.010	635	✓	✓	✓	✓	✓	✓	✓	✓	✓	✓	✓	✓	✓	✓
350	3,5/2,5	30	108 TFP	UNI	111470.350.020	635	✓	✓	✓	✓	✓	✓	✓	✓	✓	✓	✓	✓	✓	✓
350	4,4/3,2	30	72 TFP	2-10-60	111510.350.010	615	✓	✓	✓	✓	✓	✓	✓	✓	✓	✓	✓	✓	✓	✓
350	4,4/3,2	60	72 TFP	2-14-100	111510.350.020	615	✓	✓	✓	✓	✓	✓	✓	✓	✓	✓	✓	✓	✓	✓
350	3,5/2,5	30	72 HDF-P	UNI	111600.350.010	637	✓	✓	✓	✓	✓	✓	✓	✓	✓	✓	✓	✓	✓	✓
350	3,5/2,5	30	72 HDF-N	UNI	111602.350.010	639	✓	✓	✓	✓	✓	✓	✓	✓	✓	✓	✓	✓	✓	✓
350	2,9/2,2	30	84 HTT-P	UNI	111604.350.010	641	✓	✓	✓	✓	✓	✓	✓	✓	✓	✓	✓	✓	✓	✓
350	3,5/2,2	30	108 WZE-P	UNI	111610.350.010	643	✓	✓	✓	✓	✓	✓	✓	✓	✓	✓	✓	✓	✓	✓
350	3,5/2,5	30	108 WZE-N	UNI	111615.350.010	645	✓	✓	✓	✓	✓	✓	✓	✓	✓	✓	✓	✓	✓	✓
355	2,2/1,8	25,4	60 FF	-	107100.355.010	538	✓	✓	✓	✓	✓	✓	✓	✓	✓	✓	✓	✓	✓	✓
355	2,2/1,8	25,4	80 FF	-	107100.355.020	538	✓	✓	✓	✓	✓	✓	✓	✓	✓	✓	✓	✓	✓	✓
355	2,2/1,8	25,4	90 FF	1-12-55,4	107100.355.030	538	✓	✓	✓	✓	✓	✓	✓	✓	✓	✓	✓	✓	✓	✓
355	2,4/2,0	25,4	72 TFP	-	107200.355.010	539	✓	✓	✓	✓	✓	✓	✓	✓	✓	✓	✓	✓	✓	✓
355	2,2/1,8	25,4	84 / 3-Cut	-	107300.355.010	540	✓	✓	✓	✓	✓	✓	✓	✓	✓	✓	✓	✓	✓	✓
355	2,2/1,8	25,4	100 FF	-	107400.355.010	541	✓	✓	✓	✓	✓	✓	✓	✓	✓	✓	✓	✓	✓	✓
355	2,6/2,0	30/25,4	36 WZ	UNI1+UNI2	108055.355.010	543	✓	✓	✓	✓	✓	✓	✓	✓	✓	✓	✓	✓	✓	✓
355	2,6/2,0	30/25,4	54 WZ	UNI1+UNI2	108055.355.020	543	✓	✓	✓	✓	✓	✓	✓	✓	✓	✓	✓	✓	✓	✓
355	2,6/2,0	30/25,4	72 WWF	UNI1+UNI2	108055.355.030	543	✓	✓	✓	✓	✓	✓	✓	✓	✓	✓	✓	✓	✓	✓
355	3,2/2,2	30	54 WZ	UNI	111260.355.010	599	✓	✓	✓	✓	✓	✓	✓	✓	✓	✓	✓	✓	✓	✓
355	3,2/2,2	30	30 WZ	UNI	111400.355.010	668	✓	✓	✓	✓	✓	✓	✓	✓	✓	✓	✓	✓	✓	✓
355	3,2/2,2	30	60 WZ	UNI	111400.355.020	668	✓	✓	✓	✓	✓	✓	✓	✓	✓	✓	✓	✓	✓	✓
355	4,4/3,2	75	72 TFP	-	111510.355.010	615	✓	✓	✓	✓	✓	✓	✓	✓	✓	✓	✓	✓	✓	✓
360	2,6/2,25	40	60	4-15-80 / 4-11-90	107000.360.010	532	✓	✓	✓	✓	✓	✓	✓	✓	✓	✓	✓	✓	✓	✓
360	2,6/2,25	40	72	4-15-80 / 4-11-90	107000.360.020	532	✓	✓	✓	✓	✓	✓	✓	✓	✓	✓	✓	✓	✓	✓
360	2,6/2,25	40	80	4-15-80 / 4-11-90	107000.360.030	532	✓	✓	✓	✓	✓	✓	✓	✓	✓	✓	✓	✓	✓	✓
360	2,6/2,25	40	100	4-15-80 / 4-11-90	107000.360.040	532	✓	✓	✓	✓	✓	✓	✓	✓	✓	✓	✓	✓	✓	✓
360	2,6/2,25	50	60	4-15-80 / 4-11-90	107000.360.050	532	✓	✓	✓	✓	✓	✓	✓	✓	✓	✓	✓	✓	✓	✓
360	2,6/2,25	50	72	4-15-80 / 4-11-90	107000.360.060	532	✓	✓	✓	✓	✓	✓	✓	✓	✓	✓	✓	✓	✓	✓
360	2,6/2,25	50	80	4-15-80 / 4-11-90	107000.360.070	532	✓	✓	✓	✓	✓	✓	✓	✓	✓	✓	✓	✓	✓	✓
360	2,6/2,25	50	100	4-15-80 / 4-11-90	107000.360.080	532	✓	✓	✓	✓	✓	✓	✓	✓	✓	✓	✓	✓	✓	✓
360	2,6/2,25	40	60	4-15-80 / 4-11-90	107001.360.010	533	✓	✓	✓	✓	✓	✓	✓	✓	✓	✓	✓	✓	✓	✓
360	2,6/2,25	40	72	4-15-80 / 4-11-90	107001.360.020	533	✓	✓	✓	✓	✓	✓	✓	✓	✓	✓	✓	✓	✓	✓
360	2,6/2,25	40	80	4-15-80 / 4-11-90	107001.360.030	533	✓	✓	✓	✓	✓	✓	✓	✓	✓	✓	✓	✓	✓	✓
360	2,6/2,25	40	100	4-15-80 / 4-11-90	107001.360.040	533	✓	✓	✓	✓	✓	✓	✓	✓	✓	✓	✓	✓	✓	✓
360	2,6/2,25	50	60	4-15-80 / 4-11-90	107001.360.050	533	✓	✓	✓	✓	✓	✓	✓	✓	✓	✓	✓	✓	✓	✓
360	2,6/2,25	50	72	4-15-80 / 4-11-90	107001.360.060	533	✓	✓	✓	✓	✓	✓	✓	✓	✓	✓	✓	✓	✓	✓
360	2,6/2,25	50	80	4-15-80 / 4-11-90	107001.360.070	533	✓	✓	✓	✓	✓	✓	✓	✓	✓	✓	✓	✓	✓	✓
360	2,6/2,25	50	100	4-15-80 / 4-11-90	107001.360.080	533	✓	✓	✓	✓	✓	✓	✓	✓	✓	✓	✓	✓	✓	✓
370	3,6/3,0	30	96 TFP	UNI1+UNI2	111000.370.010	565	✓	✓	✓	✓	✓	✓	✓	✓	✓	✓	✓	✓	✓	✓
370	3,6/3,0	30	90 TFN	UNI1+UNI2	111100.370.010	569	✓	✓	✓	✓	✓	✓	✓	✓	✓	✓	✓	✓	✓	✓

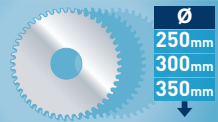

Finder nach Blatt-Ø aufsteigend + Anwendung

Finder by blade-Ø + application

✓ OPTIMAL OPTIMAL ✓ GUT GOOD ✓ MÖGLICH POSSIBLE



Weichholz, Hartholz, Exotenholz, Quer	Weichholz, Hartholz, Exotenholz Längs	Holz mit Einschlüssen wie Nägel, Klammern, Beton- und Mörtelreste	Leimholz, Tischler- und Furniersperrholz, Schichtholzplatten	Spanplatten, Hartfaserplatten, Platten ohne Belag LDF, MDF, HDF	Spanplatten, Hartfaserplatten Kunststoff beschichtet/ furniert, MDF, HDF
Soft wood, hard wood, and exotic wood across the grain	Soft wood, hard wood, and exotic wood along the grain	Wood with inclusions like nails, clips, concrete residues	Bonded wood, blockboard and veneer plywood, laminated wood	Chipboard, hard fibre board, boards without laminate LDF, MDF, HDF	Chipboard, hard fibre board, plastic-coated/ veneered, MDF, HDF

						ART.	
370	3,6/3,0	30	108 TFN	UNI1+UNI2	111100.370.020	569	
370	4,2/2,5	30	26 WZ	UNI	111215.370.010	651	✓
370	4,2/2,5	30	60 WZ	UNI	111300.370.010	659	✓
380	3,8/3,2	32	90 TFN	UNI2	111100.380.010	569	
380	3,8/3,2	32	110 TFN	UNI2	111100.380.020	569	
380	3,8/3,2	32	132 TFN	UNI2	111100.380.030	569	
380	4,8/3,5	60	72 TFP	2-14-100	111510.380.010	615	
380	4,4/3,2	60	72 TFP	2-14-100	111510.380.020	615	
390	3,5/2,5	25	60 WZ	6-6,0-66	111340.390.010	672	✓
400	5,0/4,5	50	50 SPR	4-14-80	107050.400.010	535	
400	5,0/4,5	50	50 TFB	4-14-80	107050.400.020	535	
400	5,0/4,5	50	60 SPR	4-14-80	107050.400.030	535	
400	5,0/4,5	50	60 TFB	4-14-80	107050.400.040	535	
400	5,0/4,5	50	70 SPR	4-14-80	107050.400.050	535	
400	5,0/4,5	50	70 TFB	4-14-80	107050.400.060	535	
400	5,0/4,5	50	80 SPR	4-14-80	107050.400.070	535	
400	5,0/4,5	50	80 TFB	4-14-80	107050.400.080	535	
400	2,6/3,0	30	84 FF	UNI1+UNI2	107100.400.010	538	
400	2,6/2,2	30	90 / 3-Cut	UNI1+UNI2	107300.400.010	540	
400	2,6/2,0	30	110 FF	UNI1+UNI2	107400.400.010	541	
400	2,8/2,2	30	42 WZ	UNI1+UNI2	108055.400.010	543	✓
400	2,8/2,2	30	60 WZ	UNI1+UNI2	108055.400.020	543	✓
400	2,8/2,2	30	84 WWF	UNI1+UNI2	108055.400.030	543	✓
400	4,0/3,2	30	70 POS	UNI	109000.400.010	547	
400	3,6/3,0	30	98 NEG	UNI	109000.400.020	547	
400	3,8/3,2	30	72 TFP	UNI1+UNI2	111000.400.010	565	
400	3,8/3,2	30	96 TFP	UNI1+UNI2	111000.400.020	565	
400	3,8/3,2	30	120 TFP	UNI1+UNI2	111000.400.030	565	
400	3,8/3,2	32	96 TFP	UNI2	111000.400.040	565	
400	3,8/3,2	40	96 TFP	4-12-64+2-15-80	111000.400.050	565	
400	3,8/3,2	40	120 TFP	4-12-64+2-15-80	111000.400.060	565	
400	3,8/3,2	50	96 TFP	4-15-80	111000.400.070	565	
400	3,8/3,2	50	120 TFP	4-15-80	111000.400.080	565	
400	3,1/2,5	30	128 TFPD	UNI1+UNI2	111050.400.010	567	
400	3,8/3,2	30	96 TFN	UNI1+UNI2	111100.400.010	569	
400	3,8/3,2	30	108 TFN	UNI1+UNI2	111100.400.020	569	
400	3,8/3,2	30	120 TFN	UNI1+UNI2	111100.400.030	569	
400	3,8/3,2	32	96 TFN	UNI2	111100.400.040	569	
400	3,8/3,2	32	108 TFN	UNI2	111100.400.050	569	
400	3,8/3,2	32	120 TFN	UNI2	111100.400.060	569	
400	3,8/3,2	40	96 TFN	4-12-64+2-15-80	111100.400.070	569	
400	3,8/3,2	40	120 TFN	4-12-64+2-15-80	111100.400.080	569	
400	3,8/3,2	50	96 TFN	4-15-80	111100.400.090	569	
400	3,8/3,2	50	120 TFN	4-15-80	111100.400.100	569	
400	3,1/2,5	30	130 TFND	UNI1+UNI2	111120.400.010	571	
400	3,5/2,5	30	28 WZA	UNI	111200.400.010	650	✓
400	3,5/2,5	30	36 WZA	UNI	111200.400.020	650	✓
400	3,5/2,5	30	28 WZ	UNI	111215.400.010	651	✓
400	3,5/2,5	30	36 WZ	UNI	111215.400.020	651	✓
400	3,5/2,5	30	48 WZ	UNI	111215.400.030	651	✓
400	3,5/2,5	30	18 FLA	UNI	111230.400.010	653	✓
400	4,4/2,8	30	18 FLA	UNI	111230.400.010	653	✓
400	4,4/2,8	30	24 WZA	UNI	111230.400.020	653	✓
400	3,5/2,5	30	28 FLA	UNI	111230.400.020	653	✓
400	4,0/2,8	30	24 FZ+R	UNI	111232.400.010	654	✓
400	4,0/2,8	30	28 WZ+R	UNI	111232.400.020	654	✓
400	4,0/2,8	30	36 WZ+R	UNI	111235.400.010	655	✓
400	4,0/2,8	Ø=70 / =13x5 / =20x6,5	24 FZ+R	-	111238.400.010	656	✓

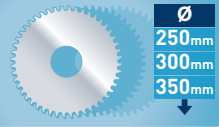

Finder nach Blatt-Ø aufsteigend + Anwendung

Finder by blade-Ø + application

✓ OPTIMAL
OPTIMAL

✓ GUT
GOOD

✓ MÖGLICH
POSSIBLE

Weichholz, Hartholz, Exotenholz, Quer	Weichholz, Hartholz, Exotenholz Längs	Holz mit Einschlüssen wie Nägel, Klammern, Beton- und Mörtelreste	Leimholz, Tischler- und Furniersperrholz, Schichtholzplatten	Spanplatten, Hartfaserplatten, Platten ohne Belag LDF, MDF, HDF	Spanplatten, Kunststoff beschichtet/ furniert, MDF, HDF
Soft wood, hard wood, and exotic wood across the grain	Soft wood, hard wood, and exotic wood along the grain	Wood with inclusions like nails, clips, concrete residues	Bonded wood, blockboard and veneer plywood, laminated wood	Chipboard, hard fibre board, boards without laminate LDF, MDF, HDF	Chipboard, hard fibre board, plastic-coated/ veneered, MDF, HDF

						ART.									
400	4,0/2,8	Ø=80 / =14x5 / =22x6,5	24 FZ+R	-	111238.400.020	656									
400	4,0/2,8	Ø=70 / =13x5 / =20x6,5	24 FZ+R	-	111239.400.010	657									
400	4,0/2,8	Ø=80 / =14x5 / =22x6,5	24 FZ+R	-	111239.400.020	657									
400	4,2/2,8	30	28 FWF	UNI	111250.400.010	598									
400	3,5/2,5	30	60 WZ	UNI	111260.400.010	599									
400	3,5/2,5	30	60 WZ	UNI	111300.400.010	659									
400	3,5/2,5	30	84 WZ	UNI	111300.400.020	659									
400	3,5/2,5	30	96 WZ	UNI	111300.400.030	659									
400	3,5/2,5	30	120 WZ	UNI	111300.400.040	659									
400	3,0/2,2	30	120 WFA	UNI	111320.400.010	661									
400	2,8/2,2	30	60 WZ	UNI	111425.400.010	663									
400	2,8/2,2	30	96 WZ	UNI	111425.400.020	663									
400	2,8/2,2	30	120 WZ	UNI	111425.400.030	663									
400	3,2/2,5	30	120 TFF-P	UNI	111430.400.010	631									
400	4,4/2,8	30	48 WZN	UNI	111450.400.010	665									
400	3,5/2,5	30	120 TFF-P	UNI	111460.400.010	633									
400	3,5/2,5	30	120 TFP	UNI	111470.400.010	635									
400	3,5/2,5	30	78 HDF-P	UNI	111600.400.010	637									
410	4,2/2,5	30	28 WZ	UNI	111215.410.010	651									
410	4,2/2,5	30	60 WZ	UNI	111300.410.010	659									
420	5,0/4,5	50	48 SPR	4-14-80	107050.420.010	535									
420	5,0/4,5	50	48 TFB	4-14-80	107050.420.020	535									
420	5,0/4,5	50	60 SPR	4-14-80	107050.420.030	535									
420	5,0/4,5	50	60 TFB	4-14-80	107050.420.040	535									
420	5,0/4,5	50	80 SPR	4-14-80	107050.420.050	535									
420	5,0/4,5	50	80 TFB	4-14-80	107050.420.060	535									
420	2,6/3,0	30	84 FF	UNI1+UNI2	107100.420.010	538									
420	2,6/2,2	30	96 / 3-Cut	UNI1+UNI2	107300.420.010	540									
420	2,6/2,0	30	110 FF	UNI1+UNI2	107400.420.010	541									
420	2,8/2,2	30	42 WZ	UNI1+UNI2	108055.420.010	543									
420	2,8/2,2	30	60 WZ	UNI1+UNI2	108055.420.020	543									
420	2,8/2,2	30	84 WWF	UNI1+UNI2	108055.420.030	543									
420	4,0/3,2	30	72 TFP	UNI1+UNI2+2-10,5-70	111000.420.010	565									
420	4,0/3,2	30	96 TFP	UNI1+UNI2+2-10,5-70	111000.420.020	565									
420	4,0/3,2	30	120 TFP	UNI1+UNI2+2-10,5-70	111000.420.030	565									
420	3,4/2,8	30	132 TFPD	UNI1+UNI2+2-10,5-70	111050.420.010	567									
420	4,0/3,2	30	96 TFN	UNI1+UNI2+2-10,5-70	111100.420.010	569									
420	4,0/3,2	30	108 TFN	UNI1+UNI2+2-10,5-70	111100.420.020	569									
420	4,0/3,2	30	120 TFN	UNI1+UNI2+2-10,5-70	111100.420.030	569									
420	4,0/3,2	40	96 TFN	4-12-64+2-15-80	111100.420.040	569									
420	4,0/3,2	40	108 TFN	4-12-64+2-15-80	111100.420.050	569									
420	4,0/3,2	40	120 TFN	4-12-64+2-15-80	111100.420.060	569									
420	3,4/2,8	30	132 TFND	UNI1+UNI2+2-10,5-70	111120.420.010	571									
420	4,2/2,8	40/30	48 WZN	2-10-60+2-11-63+2-12-64	111450.420.010	665									
420	3,5/2,5	40/30	84 WZN	2-10-60+2-11-63+2-12-64	111450.420.020	665									
425	2,6/2,25	50	60	4-15-80 / 4-11-90	107000.425.010	532									
425	2,6/2,25	50	80	4-15-80 / 4-11-90	107000.425.020	532									
425	2,6/2,25	50	100	4-15-80 / 4-11-90	107000.425.030	532									
425	2,6/2,25	50	60	4-15-80 / 4-11-90	107001.425.010	533									
425	2,6/2,25	50	80	4-15-80 / 4-11-90	107001.425.020	533									
425	2,6/2,25	50	100	4-15-80 / 4-11-90	107001.425.030	533									
430	4,0/3,2	30	96 TFP	UNI1+UNI2+2-10,5-70	111000.430.010	565									
450	2,8/2,4	30	90 FF	UNI1+UNI2	107100.450.010	538									
450	2,8/2,4	30	108 / 3-Cut	UNI1+UNI2	107300.450.010	540									
450	2,8/2,4	30	120 FF	UNI1+UNI2	107400.450.010	541									
450	3,2/2,5	30	48 WZ	UNI1+UNI2	108055.450.010	543									
450	3,2/2,5	30	72 WZ	UNI1+UNI2	108055.450.020	543									
450	3,2/2,5	30	96 WWF	UNI1+UNI2	108055.450.030	543									

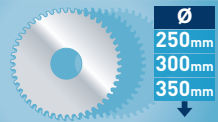

Finder nach Blatt-Ø aufsteigend + Anwendung

Finder by blade-Ø + application

✓ OPTIMAL
OPTIMAL

✓ GUT
GOOD

✓ MÖGLICH
POSSIBLE



Weichholz,
Hartholz,
Exotenholz,
Quer

Soft wood,
hard wood,
and exotic
wood across
the grain

Weichholz,
Hartholz,
Exotenholz
Längs

Soft wood,
hard wood,
and exotic
wood along the
grain

Holz mit Ein-
schlüssen wie
Nägel, Klammern,
Beton- und
Mörtelreste

Wood with
inclusions
like nails,
clips, concrete
residues

Leimholz, Tisch-
ler- und Furnier-
sperrholz,
Schichtholz-
platten

Bonded wood,
blockboard
and veneer
plywood,
laminated wood

Spanplatten,
Hartfaserplatten,
Platten ohne
Belag LDF,
MDF, HDF

Chipboard,
hard fibre board,
boards without
laminate LDF,
MDF, HDF

Spanplatten,
Kunststoff
beschichtet/
furniert, MDF, HDF

Chipboard, hard
fibre board,
plastic-coated/
veneered, MDF,
HDF

						ART.												
450	4,0/3,2	30	72 TFP	UNI1+UNI2+2-10,5-70	111000.450.010	565												
450	4,0/3,2	30	108 TFP	UNI1+UNI2+2-10,5-70	111000.450.020	565												
450	4,0/3,2	30	120 TFP	UNI1+UNI2+2-10,5-70	111000.450.030	565												
450	4,0/3,2	32	96 TFP	UNI2	111000.450.040	565												
450	4,0/3,2	32	120 TFP	UNI2	111000.450.050	565												
450	3,4/2,8	30	138 TFPN	UNI1+UNI2+2-10,5-70	111050.450.010	567												
450	4,0/3,2	30	108 TFN	UNI1+UNI2+2-10,5-70	111100.450.010	569												
450	4,0/3,2	30	128 TFN	UNI1+UNI2+2-10,5-70	111100.450.020	569												
450	3,4/2,8	30	138 TFND	UNI1+UNI2+2-10,5-70	111120.450.010	571												
450	4,2/2,8	30	32 WZA	UNI	111200.450.010	650	✓		✓		✓		✓					
450	4,2/2,8	30	40 WZA	UNI	111200.450.020	650	✓		✓		✓		✓					
450	4,2/2,8	30	40 WZ	UNI	111215.450.010	651	✓		✓		✓		✓					
450	4,5/2,8	30	20 FLA	UNI	111230.450.010	653	✓		✓		✓		✓					
450	4,5/2,8	30	28 WZA	UNI	111230.450.020	653	✓		✓		✓		✓					
450	4,2/2,8	30	28 FZ+R	UNI	111232.450.010	654	✓		✓		✓		✓					
450	4,0/2,8	30	36 WZ+R	UNI	111232.450.020	654	✓		✓		✓		✓					
450	4,2/2,8	30	40 WZ+R	UNI	111235.450.010	655	✓		✓		✓		✓					
450	4,4/3,2	Ø=70 / =13x5 / x20x6,5	28 FZ+R	-	111238.450.010	656			✓		✓		✓					
450	4,4/3,2	Ø=80 / =14x5 / =22x6,5	28 FZ+R	-	111238.450.020	656			✓		✓		✓					
450	4,2/2,8	30	32 FWF	UNI	111250.450.010	598	✓		✓		✓		✓					
450	3,5/2,5	30	66 WZ	UNI	111260.450.010	599	✓		✓		✓		✓					✓
450	4,0/2,8	30	66 WZ	UNI	111300.450.010	659	✓		✓		✓		✓					✓
450	4,0/2,8	30	84 WZ	UNI	111300.450.020	659	✓		✓		✓		✓					✓
450	4,0/2,8	30	108 WZ	UNI	111300.450.030	659	✓		✓		✓		✓					✓
450	4,0/2,8	30	132 WZ	UNI	111300.450.040	659	✓		✓		✓		✓					✓
450	3,6/2,8	30	130 WFA	UNI	111320.450.010	661	✓		✓		✓		✓					✓
450	3,1/2,5	30	66 WZ	UNI	111425.450.010	663	✓		✓		✓		✓					✓
450	3,1/2,5	30	108 WZ	UNI	111425.450.020	663	✓		✓		✓		✓					✓
450	3,1/2,5	30	130 WZ	UNI	111425.450.030	663	✓		✓		✓		✓					✓
450	3,5/2,8	30	132 TFF-P	UNI	111430.450.010	631			✓		✓		✓					✓
450	4,4/2,8	30	54 WZN	UNI	111450.450.010	665	✓		✓		✓		✓					✓
450	4,8/3,5	60	72 TFP	2-14-125	111510.450.010	615											✓	✓
460	2,7/2,25	50	60	4-15-80 / 4-11-90	107000.460.010	532												
460	2,7/2,25	50	80	4-15-80 / 4-11-90	107000.460.020	532												
460	2,7/2,25	50	100	4-15-80 / 4-11-90	107000.460.030	532												
460	2,7/2,25	50	60	4-15-80 / 4-11-90	107001.460.010	533												
460	2,7/2,25	50	80	4-15-80 / 4-11-90	107001.460.020	533												
460	2,7/2,25	50	100	4-15-80 / 4-11-90	107001.460.030	533												
500	5,0/4,5	50	54 SPR	4-18-100	107050.500.010	535												
500	5,0/4,5	50	54 TFB	4-18-100	107050.500.020	535												
500	5,0/4,5	50	60 SPR	4-18-100	107050.500.030	535												
500	5,0/4,5	50	60 TFB	4-18-100	107050.500.040	535												
500	5,0/4,5	50	70 SPR	4-18-100	107050.500.050	535												
500	5,0/4,5	50	70 TFB	4-18-100	107050.500.060	535												
500	3,0/2,6	30	100 FF	UNI1+UNI2	107100.500.010	538												
500	3,0/2,6	30	120 / 3-Cut	UNI1+UNI2	107300.500.010	540												
500	3,0/2,6	30	130 FF	UNI1+UNI2	107400.500.010	541												
500	3,4/2,8	30	54 WZ	UNI1+UNI2	108055.500.010	543	✓		✓		✓		✓					✓
500	3,4/2,8	30	84 WZ	UNI1+UNI2	108055.500.020	543	✓		✓		✓		✓					✓
500	3,4/2,8	30	108 WWF	UNI1+UNI2	108055.500.030	543	✓		✓		✓		✓					✓
500	4,2/3,6	30	72 TFP	UNI1+UNI2+2-10,5-70	111000.500.010	565												
500	4,2/3,6	30	96 TFP	UNI1+UNI2+2-10,5-70	111000.500.020	565												
500	4,2/3,6	30	120 TFP	UNI1+UNI2+2-10,5-70	111000.500.030	565												
500	4,2/3,6	30	144 TFP	UNI1+UNI2+2-10,5-70	111000.500.040	565												
500	4,2/3,6	32	120 TFP	UNI2	111000.500.050	565												
500	4,2/3,6	32	144 TFP	UNI2	111000.500.060	565												
500	3,4/2,8	30	144 TFPN	UNI1+UNI2+2-10,5-70	111050.500.010	567												
500	4,2/3,6	30	120 TFN	UNI1+UNI2+2-10,5-70	111100.500.010	569												



- 1
- 2
- 3
- 4
- 5
- 6
- 7
- 8
- 9
- 10

	Type	Ø			Type	Ø			Type	Ø	
AEG + Atlas Copco	HK 125	120	20	Black & Decker	DN 227	140	12,7	Black & Decker	KS 865 N	180/184	16
AEG + Atlas Copco	HK 125 A	125	20	Black & Decker	DN 227 H	140	12,7	Black & Decker	P 3703	180/184	16
AEG + Atlas Copco	HK 125 B	125	20	Black & Decker	HK 600	140	12,7	Black & Decker	P 3703 L	180/184	16
AEG + Atlas Copco	HK 25	125	20	Black & Decker	KS 227	140	12,7	Black & Decker	P 3705	180/184	16
AEG + Atlas Copco	HK 40	140	20	Black & Decker	KS 40	140	12,7	Black & Decker	PL 40	180/184	16
AEG + Atlas Copco	TK 40	140	20	Black & Decker	KS 840	140	12,7	Black & Decker	SEC 718	180/184	16
AEG + Atlas Copco	AHK 52	150	20	Black & Decker	KS 846	140	12,7	Black & Decker	SEC-6 S	180/184	16
AEG + Atlas Copco	HK 45	150	20	Black & Decker	KS 846 N	140	12,7	Black & Decker	SR 300	180/184	16
AEG + Atlas Copco	HK 45 A	150	20	Black & Decker	P 3501	140	12,7	Black & Decker	SR 362 E	180/184	16
AEG + Atlas Copco	HK 46	150	20	Black & Decker	P 8809 (12 V)	150	20	Bosch	Schattenfugensäge	102	22
AEG + Atlas Copco	HK 46 N	150	20	Black & Decker	P-3601	156	12,7	Bosch	PSF 22		
AEG + Atlas Copco	HK 46 S	150	20	Black & Decker	BD 855	160	16	Bosch	GUF 22 A	105	20
AEG + Atlas Copco	HK 50	150	20	Black & Decker	BD 855 C	160	16	Bosch	PFS 2	105	20
AEG + Atlas Copco	HK 52	150	20	Black & Decker	KS 850	160	16	Bosch	PKS 14.4 V	130	16
AEG + Atlas Copco	HK 717	150	20	Black & Decker	KS 850 N	160	16	Bosch	PKS 38	130	16
AEG + Atlas Copco	HK 727	150	20	Black & Decker	KS 855	160	16	Bosch	PKS 40	130	16
AEG + Atlas Copco	HK 737	150	20	Black & Decker	KS 855 N	160	16	Bosch	PKS 40 S	130	16
AEG + Atlas Copco	HKS 46	150	20	Black & Decker	M 336	160	16	Bosch	S 43	130	16
AEG + Atlas Copco	HKS 46 S	150	20	Black & Decker	M 975	160	16	Bosch	1551	140	20
AEG + Atlas Copco	HKS 52	150	20	Black & Decker	M 976	160	16	Bosch	1559	140	20
AEG + Atlas Copco	HTK 717	150	20	Black & Decker	SR 325 E	160	16	Bosch	KS 5500 - Plus	140	20
AEG + Atlas Copco	HTK 727	150	20	Black & Decker	U 336	160	16	Bosch	GB 1923	150	16
AEG + Atlas Copco	CS 55 (Atlas Copco)	160	20	Black & Decker	U 975	160	16	Bosch	GKS 12	150	16
AEG + Atlas Copco	HK 160 A	160	20	Black & Decker	U 976	160	16	Bosch	GKS 46	150	16
AEG + Atlas Copco	HK 160 B	160	20	Black & Decker	CD 601	170	16	Bosch	PKS 46	150	16
AEG + Atlas Copco	HK 55	160	20	Black & Decker	CD 602	170	16	Bosch	PKS 48	150	16
AEG + Atlas Copco	HK 55 A	160	20	Black & Decker	KS 55	170	16	Bosch	S 1	150	16
AEG + Atlas Copco	HK 55 B	160	20	Black & Decker	2062	180	20	Bosch	S 33	150	16
AEG + Atlas Copco	HKS 55	160	20	Black & Decker	DNS 9	180	16	Bosch	GKS 160	160	20
AEG + Atlas Copco	K 55	160	20	Black & Decker	HD 1200	180	20	Bosch	GKS 24 V	160	20
AEG + Atlas Copco	K 55 E	160	20	Black & Decker	P 36-05	184	16	Bosch	GKS 54	160	16
AEG + Atlas Copco	K 55 S	160	20	Black & Decker	BD 365	190	30	Bosch	GKS 54 C	160	16
AEG + Atlas Copco	K 55 SE	160	20	Black & Decker	U 338	200	16	Bosch	GKS 54 CE	160	16
AEG + Atlas Copco	KS 55 S	160	20	Black & Decker	BD 800	210	30	Bosch	GKS 54 E	160	16
AEG + Atlas Copco	KS 55 SE	160	20	Black & Decker	DN 800	210	30	Bosch	GKS 55	160	20
AEG + Atlas Copco	PC 555	160	20	Black & Decker	DN 810	210	30	Bosch	GKS 55 CE	160	20
AEG + Atlas Copco	CS 66 (Atlas Copco)	190	30	Black & Decker	KS 800	210	30	Bosch	GKS 59	160	16
AEG + Atlas Copco	HK 190	190	30	Black & Decker	KS 810	210	30	Bosch	PKS 54	160	16
AEG + Atlas Copco	HK 64 A	190	30	Black & Decker	SEC 818	210	30	Bosch	PKS 54 CE	160	16
AEG + Atlas Copco	HK 65	190	30	Black & Decker	SR 700	210	30	Bosch	GKS 18 V-LI	165	20
AEG + Atlas Copco	HK 65 A	190	30	Black & Decker	HD 2086 S	230	30	Bosch	GKS 36 V-LI	165	20
AEG + Atlas Copco	HK 66	190	30	Black & Decker	P 39-02	230	30	Bosch	1550	170	30
AEG + Atlas Copco	HK 66 SE	190	30	Black & Decker	SEC 918	230	30	Bosch	1552	170	30
AEG + Atlas Copco	HKE 65	190	30	Black & Decker	HD 1215	235	30	Bosch	1556	170	30
AEG + Atlas Copco	HKE 66	190	30	Black & Decker	HD 2086	235	30	Bosch	1563	170	30
AEG + Atlas Copco	HKS 190	190	30	Black & Decker	HD 2086 S	235	30	Bosch	1567	170	30
AEG + Atlas Copco	HKS 64 A	190	30	Black & Decker	P 39-02	235	30	Bosch	1553	180	30
AEG + Atlas Copco	HKS 65	190	30	Black & Decker	SEC 91 S	235	30	Bosch	6317	180	30
AEG + Atlas Copco	HKS 65 A	190	30	Black & Decker	SEC 918	235	30	Bosch	0551	180	30
AEG + Atlas Copco	HKS 66	190	30	Black & Decker	D 2702	125/127	12,7	Bosch	1564	190	30
AEG + Atlas Copco	HKS 66 E	190	30	Black & Decker	D 2712	125/127	12,7	Bosch	0051	190	30
AEG + Atlas Copco	HKSE 190	190	30	Black & Decker	D 984	125/127	12,7	Bosch	GKS 65	190	30
AEG + Atlas Copco	HKSE 65	190	30	Black & Decker	D 985	125/127	12,7	Bosch	GKS 66	190	30
AEG + Atlas Copco	HKSE 65 A	190	30	Black & Decker	DN 254	125/127	12,7	Bosch	GKS 66 C	190	30
AEG + Atlas Copco	HKSE 66	190	30	Black & Decker	DN 55	125/127	12,7	Bosch	GKS 66 CE	190	30
AEG + Atlas Copco	K 66 S	190	30	Black & Decker	DN 56	125/127	12,7	Bosch	P 30	190	30
AEG + Atlas Copco	K 66 SE	190	30	Black & Decker	DN 984	125/127	12,7	Bosch	P 300	190	30
AEG + Atlas Copco	KS 65	190	30	Black & Decker	DN 985	125/127	12,7	Bosch	PKS 65	190	30
AEG + Atlas Copco	KS 66 S	190	30	Black & Decker	KC 1440 SK	130/134	10	Bosch	PKS 66	190	30
AEG + Atlas Copco	SCS 66 Q	190	30	Black & Decker	BD 228	156/160	12,7	Bosch	PKS 66 CE	190	30
AEG + Atlas Copco	HK 201	200	30	Black & Decker	BD 228 CK	156/160	12,7	Bosch	1561	200	30
AEG + Atlas Copco	CS 75	210	30	Black & Decker	BD 228 L	156/160	12,7	Bosch	1554	210	30
AEG + Atlas Copco	HK 75	210	30	Black & Decker	DN 228	156,5/160	12,7	Bosch	1558	210	30
AEG + Atlas Copco	HK 75 A	210	30	Black & Decker	DN 57	156,5/160	12,7	Bosch	1565	210	30
AEG + Atlas Copco	HKS 75	210	30	Black & Decker	P 3601	156,5/160	12,7	Bosch	GKS 75 S	210	30
AEG + Atlas Copco	HKS 35	230	30	Black & Decker	P 3601 L	156,5/160	12,7	Bosch	1562	230	30
AEG + Atlas Copco	HKS 85	230	30	Black & Decker	SR 352	156,5/160	12,7	Bosch	1566	230	30
AEG + Atlas Copco	HK 240	240	30	Black & Decker	SR 352 E	156,5/160	12,7	Bosch	1662	230	30
AEG + Atlas Copco	MS 3 C	250	30	Black & Decker	374456 N	180/184	16	Bosch	0052	230	30
AEG + Atlas Copco	MK 65	280	30	Black & Decker	BD 229	180/184	16	Bosch	0552	230	30
AEG + Atlas Copco	MKS 65	280	30	Black & Decker	BD 59	180/184	16	Bosch	GKS 85 S	230	30
AEG + Atlas Copco	PC 300	130/132/134	20	Black & Decker	BD 865	180/184	16	Bosch	1555	240	30
AEG + Atlas Copco	TKS 42	130/132/134	20	Black & Decker	BD 865 C	180/184	16	Bosch	GUF 422 A	102/105	20/22
AEG + Atlas Copco	HK 707	140/143	20	Black & Decker	BD 865 E	180/184	16	Bosch	PSF 22 A	102/105	20/22
AEG + Atlas Copco	HK 86	140/143	20	Black & Decker	BD 865 EC	180/184	16	Bosch	GKS 12 V	150/160	16
AEG + Atlas Copco	HTK 707	140/143	20	Black & Decker	DN 229	180/184	16	Bosch	1557	170/180	30
AEG + Atlas Copco	BKS 18	160/165	15,875	Black & Decker	DN 59	180/184	16	Bosch	1560	170/180	30
AEG + Atlas Copco	BKS 18 Li	160/165	15,875	Black & Decker	DN 820	180/184	16	Bosch	0550	170/180	30
AEG + Atlas Copco	KS 55 C	160/165	30	Black & Decker	GD 60	180/184	16	Bosch	GKS 68 BC	190/200	30
AEG + Atlas Copco	KS 66 C	180/184	30	Black & Decker	HD 100	180/184	16	Brüder Mannesmann	12895	180/184	20
Alco	Pro UFS 240	220	30	Black & Decker	HD 1000	180/184	16	Casals	900 26	150	16
BATAVIA	T-RAXX BT-PS001	160	20	Black & Decker	HD 1200 P	180/184	16	Casals	SC 650	150	20
Black & Decker	BD 227	140	12,7	Black & Decker	HD 2062	180/184	16	Casals	SC 320	230	30
Black & Decker	BD 840	140	12,7	Black & Decker	KS 865	180/184	16	De Walt	DE 935 Akku	136	10
Black & Decker	BD 846	140	12,7	Black & Decker	KS 865 E	180/184	16	De Walt	DW 935	136	10
Black & Decker	CD 600	140	12,7	Black & Decker	KS 865 KN	180/184	16	De Walt	DW 935 K	136	10



	Type	Ø			Type	Ø			Type	Ø	
De Walt	DW 936	136	10	De Walt	D 23620 K	180/184	16	Elu	MH 265	190	30
De Walt	DW 936 K	136	10	De Walt	DW 62	180/184	16	Elu	MH 30	200	30
De Walt	DW 351	150	20	De Walt	DW 62 K	180/184	16	Elu	MH 182	210	30
De Walt	D 23550	165	20	Einhell	BHS 55	160	20	Elu	MH 30	210	30
De Walt	D 23551	165	20	Einhell	HES 160	160	20	Elu	MH 82	210	30
De Walt	DC 310	165	20	Einhell	HES 55	160	20	Elu	MH 182	215	30
De Walt	DC 390	165	20	Einhell	HK-G 55	160	20	Elu	MH 30	215	30
De Walt	DC 390 KA/3	165	20	Einhell	HES 200	200	30	Elu	MH 82	215	30
De Walt	DC 390 KB	165	20	Einhell	KGF 205	205	18	Elu	ETS 41	216	30
De Walt	DC 390 N	165	20	Einhell	TK 220	220	30	Elu	MH 182	216	30
De Walt	DW 007	165	10	Elektra Beckum	DS 140 - Duplo	100	22	Elu	MH 274	216	30
De Walt	DW 007 K	165	10	Elektra Beckum	MBR 100 Schattenfugensäge	100	22	Elu	PS 174	216	30
De Walt	DWS 520	165	20	Elektra Beckum	Multi 180	200	30	Elu	PS 274	216	30
De Walt	DW 934	173	20	Elektra Beckum	KS 205	205	18	Elu	PS 274 E	216	30
De Walt	DW 934 K 2	173	20	Elektra Beckum	TK 205	205	18	Elu	MH 286	240	30
De Walt	DW 934 K 2 H	173	20	Elektra Beckum	GKS 255	210	30	Elu	MH 85	240	30
De Walt	DW 62	184	16	Elektra Beckum	PK 200	210	30	Elu	ETS 21	250	30
De Walt	DW 365	190	30	Elektra Beckum	UK 220	210	30	Elu	ETS 23	250	30
De Walt	DW 65	190	30	Elektra Beckum	UK 220 E	210	30	Elu	ETS 31	250	30
De Walt	DW 700	216	30	Elektra Beckum	Secanta	220	30	Elu	ETS 33	250	30
De Walt	DW 701	216	30	Elektra Beckum	GKS 300	250	30	Elu	RAS 1251	250	30
De Walt	DW 707	216	30	Elektra Beckum	GKS 301	250	30	Elu	RAS 1253	250	30
De Walt	DW 383	235	30	Elektra Beckum	GKS 303	250	30	Elu	RKS 1251	250	30
De Walt	DW 86	240	30	Elektra Beckum	GKS 331	250	30	Elu	RKS 1253	250	30
De Walt	DW 100	250	16	Elektra Beckum	KGS 250	250	30	Elu	TGS 170	250	30
De Walt	DW 110	250	16	Elektra Beckum	KGS 300	250	30	Elu	TGS 171	250	30
De Walt	DW 111	250	16	Elektra Beckum	KGS 330	250	30	Elu	TGS 172	250	30
De Walt	DW 125	250	30	Elektra Beckum	KGS 500	250	30	Elu	TGS 173	250	30
De Walt	DW 1251	250	30	Elektra Beckum	KGT 500	250	30	Elu	TGS 271	250	30
De Walt	DW 150	250	30	Elektra Beckum	KGT 501	250	30	Elu	TGS 273	250	30
De Walt	DW 1501	250	30	Elektra Beckum	KGT 550	250	30	Elu	TKS 170	250	30
De Walt	DW 1503	250	30	Elektra Beckum	KS 250	250	20	Elu	TKS 171	250	30
De Walt	DW 250	250	30	Elektra Beckum	Multi 260	250	30	Elu	TKS 172	250	30
De Walt	DW 252	250	30	Elektra Beckum	Multi310	250	30	Elu	TKS 173	250	30
De Walt	DW 320	250	30	Elektra Beckum	PK 250	250	30/20	Elu	EMTS 711	260	30
De Walt	DW 702	250	30	Elektra Beckum	PK 250 K	250	30/20	Elu	DG 79	300	30
De Walt	DW 703	250	30	Elektra Beckum	PK 255	250	30/20	Elu	ETS 3003	300	30
De Walt	DW 710	250	30	Elektra Beckum	PKF 255	250	30/20	Elu	MGS 72	300	30
De Walt	DW 720 K	250	30	Elektra Beckum	PKF255 V 8	250	30/20	Elu	MGS 73	300	30
De Walt	DW 742	250	30	Elektra Beckum	UK 250	250	30	Elu	EMS 705	305	30
De Walt	DW 743	250	30	Elektra Beckum	UK 330	250	30/20	Elu	PS 374	305	30
De Walt	DW 744	250	30	Elektra Beckum	PK 300	300	30	Elu	RAS 1603	350	30
De Walt	DW 746 K	250	30	Elektra Beckum	PKV 300 G	300	30	Elu	RKS 1603	350	30
De Walt	DW 709	260	30	Elektra Beckum	THKS 315	315	30	Elu	MTS 24	355	25,4
De Walt	DW 711	260	30	Elektra Beckum	TK 315	315	30	Elu	DG 102	420	30
De Walt	1370	300	30	Elektra Beckum	TK Combi HSG	315	30	Elu	DG 104	420	30
De Walt	1635	300	30	Elektra Beckum	TK Export HG	315	30	Elu	MGS 105	420	30
De Walt	1875	300	30	Elektra Beckum	TKH 315	315	30	Elu	SA 103/20	420	30
De Walt	8003	300	30	Elektra Beckum	TKHS 315	315	30	Elumatec	DG 163	280	32
De Walt	1420 S	300	30	Elektra Beckum	TK 350	350	30	Elumatec	RS 160	280	32
De Walt	1600 S	300	30	Elektra Beckum	BKH 400	400	30	Elumatec	TS 161	280	32
De Walt	1635/3L	300	30	Elektra Beckum	BKH 500	400	30	Elumatec	KS 101	300	32
De Walt	1635/4L	300	30	Elektra Beckum	BKS 400	400	30	Elumatec	MGS 460	300	32
De Walt	2155/4	300	30	Elektra Beckum	BS 3100	400	30	Elumatec	DG 79/03-05	330	32
De Walt	3 L	300	30	Elektra Beckum	BS 3100 W	400	30	Elumatec	DG 79/50	330	32
De Walt	4 L	300	30	Elektra Beckum	BS 4200	400	30	Elumatec	MGS 72/04	330	32
De Walt	DW 1370	300	30	Elektra Beckum	BS 5500 W	400	30	Elumatec	MGS 73/23	330	32
De Walt	DW 721	300	30	Elektra Beckum	BKH 450	450	30	Elumatec	SA 73/25	330	32
De Walt	DW 722 K	300	30	Elektra Beckum	BKS 450	450	30	Elumatec	DG 79/30-32	380	32
De Walt	DW 725 K	300	30	Elektra Beckum	BS 6000	450	30	Elumatec	DG 79/51	380	32
De Walt	DW 726 K	300	30	Elektra Beckum	BS 8000 D	450	30	Elumatec	MGS 72/30	380	32
De Walt	DW 810	300	30	Elektra Beckum	BW 500	450	30	Elumatec	MGS 73/33	380	32
De Walt	MC 20	300	32	Elektra Beckum	BS 600	500	30	Elumatec	SA 73/35	380	32
De Walt	DW 704	305	30	Elektra Beckum	BS 6000 D	500	30	Elumatec	DG 102	420	30
De Walt	DW 705	305	30	Elektra Beckum	BW 500	500	30	Elumatec	DG 104	420	30
De Walt	DW 706	305	30	Elektra Beckum	BW 4000	700	30	Elumatec	DG 140	420	30
De Walt	DW 708	305	30	Elektra Beckum	BW 750	700	30	Elumatec	MGS 105	420	30
De Walt	1365 GL	350	30	Elu	DS 140 - Duplo	100	22	Elumatec	MGS 461	420	30
De Walt	2155 G	350	30	Elu	MBR 100 Schattenfugensäge	100	22	Elumatec	SA 103/25	420	30
De Walt	C 14	350	30	Elu	MH 25	100	12	Elumatec	DG 142	500	30
De Walt	DW 1600 S	350	30	Elu	DS 140 Doublo	102	22	Elumatec	MGS 142	500	30
De Walt	DW 728 K	350	30	Elu	DS 140 Doublo	105	22	Elumatec	SA 142	500	30
De Walt	DW 729 K	350	30	Elu	Akku	136	10	Elumatec	DG 204	550	30
De Walt	1634	400	30	Elu	MHA 14 KA	136	10	Elumatec	DG 240	550	30
De Walt	1600 S	400	30	Elu	MHA 18 KA	136	10	Elumatec	MGS 205	550	30
De Walt	1635 GL	400	30	Elu	MH 14 (alte Ausführung)	140	15	Emco	EMCOSTAR 3000	200	30
De Walt	1635/6L	400	30	Elu	MH 151	150	20	Emco	Emco-Star 3000	200	30
De Walt	2155 G	400	30	Elu	MH 18 (alte Ausführung)	150	15	Emco	Universal	200	15
De Walt	2155/6	400	30	Elu	MH 18 (neue Ausführung)	150	30	Emco	EMCO Rex 2000	250	20
De Walt	6 L	400	30	Elu	MH 155	170	30	Emco	Emco-Multistar	250	30
De Walt	C 14	400	30	Elu	MH 55	170	30	Emco	Emco-Unistar	250	30
De Walt	6 K	500	30	Elu	MH 65	180	30	Emco	MK 81	250	30
De Walt	6 L	500	30	Elu	MH 165	190	30	Emco	Super. 1011	250	20
De Walt	DA 1635	500	30	Elu				Emco	M 50 L	220	30
De Walt	DA 1635/6K + 6L	500	30	Elu				Eumenia	ML 50 L	220	30
De Walt	D 23620	180/184	16	Elu				Fein	SSK 646	150	20





	Type	Ø	
Fein	SSL 646	150	20
Fein	SSK 660	160	20
Fein	SSK 661	210	30
Felisatti	TP 751	150	20
Felisatti	TP 756	160	20
Felisatti	M 75	250	20
Felisatti	M 76	250	20
FERM	KS-160	160	20
FERM	FKS-165	165	20
FERM	FKS-165L	165	20
FERM	FKS-180	180	20
FERM	ECONOMY EBF-185	180/184	20
FERM	FDCS-185	180/184	20
FERM	FDCS-185L	180/184	20
FERM	FKS-185	180/184	20
FERM	FKS-185L	180/184	20
Festo	AUF 35 S 4 Schatten-nutsäge	105	20
Festo	AUF 35/S3,4	105	20
Festo	AU 35 S 2	120	20
Festo	Auf 35-51	120	20
Festo	AUF 35	125	20
Festo	S 4	125	20
Festo	AF 45 E	150	30
Festo	AXF 45	150	30
Festo	AAU	160	30
Festo	AP 55	160	20
Festo	AP 55 E	160	20
Festo	AP 55 E 8	160	20
Festo	AP 55 EB	160	20
Festo	AP 55 EB-Plus	160	20
Festo	AP 55 E-FS	160	20
Festo	AP 55 Plus	160	20
Festo	AP 55-FS	160	20
Festo	AT 55 EB	160	20
Festo	AT 55 EFS	160	20
Festo	AT 55 E-FS	160	20
Festo	ATB 55-EFS	160	20
Festo	ATF 55	160	20
Festo	ATF 55 - EFS	160	20
Festo	ATF 55 BE	160	20
Festo	ATF 55 E	160	20
Festo	ATF 55 EB	160	20
Festo	ATF 55 E-FS	160	20
Festo	ATF 55 FS	160	20
Festo	AU 50	160	30
Festo	AUP 50	160	30
Festo	Basis-Set 1 A	160	20
Festo	TS 55	160	20
Festo	TS 55 R	160	20
Festo	TS 55 REBQ-Plus	160	20
Festo	TS 55 REBQ-Plus-FS	160	20
Festo	TS 55 RQ-Plus	160	20
Festo	AM 42 A	170	30
Festo	AM 42 S	170	30
Festo	AM 42 STA	170	30
Festo	AMT 42 S	170	30
Festo	AT 55	170	30
Festo	AT 55 C	170	30
Festo	AU 42 A	170	30
Festo	AU 42 S	170	30
Festo	AUT 42	170	30
Festo	AXT 50 LA	170	30
Festo	AXT 55	170	30
Festo	AU 55 S	180	30
Festo	AU 60 P	180	30
Festo	AU 60 S	180	30
Festo	AUP 60 S	180	30
Festo	AUT 60 S	180	30
Festo	AP 65	190	30
Festo	AP 65 E	190	30
Festo	AP 65 E - FS	190	30
Festo	AP 65 EB - FS	190	30
Festo	AP 65 EB-FS	190	30
Festo	AP 65 E-FS	190	30
Festo	AT 65	190	30
Festo	AT 65 E	190	30
Festo	AT 65 E - FS	190	30
Festo	AT 65 EB	190	30
Festo	AT 65 EB-FS	190	30
Festo	AT 65 E-FS	190	30
Festo	ATF 65	190	30
Festo	AD 65	200	30
Festo	AP 68 E	200	30
Festo	AU 65 - S	200	30
Festo	AU 65-S	200	30

	Type	Ø	
Festo	AUP 65 S	200	30
Festo	AUT 65 S	200	30
Festo	AXP 65	200	30
Festo	AU 77 S	220	30
Festo	Compact S 70	225	30
Festo	CS 70 EB	225	30
Festo	F 70	225	30
Festo	AU 80 S	230	30
Festo	AO 85 E-FS	240	30
Festo	AP 85	240	30
Festo	AP 85 E	240	30
Festo	AP 85 E-FS	240	30
Festo	AP 88	240	30
Festo	AP 88 E	240	30
Festo	AXP 85	240	30
Festo	AD 85	250	30
Festo	AE 85	250	30
Festo	AD 100/1	280	30
Festo	AD 100	290	30
Festo	AD 100-1	290	30
Festo	AD 100-2	290	30
Festo	AXP 130	350	30
Festo	AXP 132	350	30
Festo	AXP 132 E	350	30
Festo	BD 125	350	30
Festo	BD 145/1	400	30
Festo	BD 170	450	30
Festo	AT 55 E	160/170	30
Festo	AUT 42 S	170/180	30
Fezer	KG 20	200	18
Fezer	KG 20	205	18
Fezer	KG 25	250	32
Fezer	KG 30	300	32
FLEX	CS 3455	160	20
Flott	1000	250	20
Flott	1011	250	30
Flott	2000	250	20
Flott	2011	250	30
Flott	3011	250	30
Flott	K 4500	250	30
Flott	Profi 2001	250	20
Flott	Profi 3000	250	20
Graule	TS	180	40
Graule	AKF 1	200	40
Graule	AKF 4/200	200	40
Graule	AKF 2	250	40
Graule	AKF 4/250	250	40
Graule	AKF 6/250	250	40
Graule	KS	250	40
Graule	TS	250	40
Graule	AGT	300	40
Graule	AKF 6/300	300	40
Graule	Typ 85	300	40
Graule	ZS 85	300	40
Graule	Typ 135	350	40
Graule	ZS 135	350	40
Graule	ZS 135 N	350	40
Graule	Typ 170	420	40
Graule	ZS 170	420	40
Graule	ZS 170 N	420	40
Graule	ZS 200	520	50
Gross	160 A	160	25
Gross	HKS 160 A	160	25
Gross	200 B	200	25
Gross	250 B	250	25
Güde	HKS 1200	180/184	20
Güde	HKS 1600 L	180/184	20
Haffner	RF 30	100	20
Haffner	RF 60	100	20
Haffner	KSU 40	120	20
Haffner	KSU 105	125	20
Haffner	KSU 50	160	20
Haffner	KS 110	170	30
Haffner	KSU 110	170	30
Haffner	KSU 113	180	30
Haffner	KSU 60 att	180	30
Haffner	KSU 60 neu	180	20
Haffner	KS 75	210	30
Haffner	KL 177	220	30
Haffner	KL 178	220	30
Haffner	KSU 118	220	30
Haffner	KL 176	230	30
Haffner	KS 85	230	30
Haffner	KSU 85	230	30
Haffner	SP 187	230	30
Haffner	US 85	230	30

	Type	Ø	
Haffner	2 D	250	30
Haffner	2 W	250	30
Haffner	AKS	250	30
Haffner	GS 1	250	30
Haffner	GS 150	250	30
Haffner	GS 165	250	30
Haffner	GS 166	250	30
Haffner	SP 189	250	30
Haffner	SP 195	250	30
Haffner	SP 196	250	30
Haffner	SP 197	250	30
Haffner	SP 198	250	30
Haffner	TG 161	250	30
Haffner	TG 162	250	30
Haffner	TG 163	250	30
Haffner	TGS 161	250	30
Haffner	TGS 162	250	30
Haffner	TGS 163	250	30
Haffner	TGS 198	250	30
Haffner	GS 146	300	30
Haffner	GS 147	300	30
Haffner	GS 155	300	30
Haffner	GS 156	300	30
Haffner	GS 157	300	30
Haffner	GS 158	300	30
Haffner	GS 183	300	30
Haffner	GS 183 M	300	30
Haffner	KS 120	300	30
Haffner	SP 223	300	30
Haffner	SP 224	300	30
Haffner	TGS 168	300	30
Haffner	TGS 169	300	30
Haffner	TGS 200	300	30
Haffner	DGS 180	330	30
Haffner	DGS 182	330	30
Haffner	GSA 180	330	30
Haffner	GSM 180	330	30
Haffner	GS 159	350	30
Haffner	GS 160	350	30
Haffner	DG 181	400	30
Haffner	DGS 181	400	30
Haffner	DGS 184	400	30
Haffner	DGS 184 E	400	30
Haffner	GS 184	400	30
Haffner	GSA 183	400	30
Haffner	GSM 183	400	30
Haffner	KS 155	400	30
Haffner	ZS 640	400	30
Haffner	ZS 800	400	30
Haffner	DGS 123	450	30
Haffner	DGS 125	450	30
Haffner	GS 123	450	30
Haffner	DGS 124	500	30
Haffner	DGS 126	500	30
Haffner	DGS 185	500	30
Haffner	DGS 187	500	30
Haffner	DGS 202	500	30
Haffner	GS 124	500	30
Haffner	GS 161	500	30
Haffner	GS 162	500	30
Hanning	TK 20 N	200	16
Hanning	TK 20 S	200	16
Hanning	TK 200	200	16
Hanning	TK 300	200	16
Hanning	ZK 205	200	16
Hanning	3 SV	315	30
Hanning	315/1.6	315	30
Hanning	315/3.0	315	30
Hanning	4.0	315	30
Hanning	HTK 315	315	30
Hanning	HTK 315/3 SV	315	30
Hilti	WSC 255	160	20
Hilti	WSC 55	160	20
Hilti	WSC 85	230	30
Hitachi	C 5 Y	125	20
Hitachi	C 5	150	20
Hitachi	CM 6	150	20
Hitachi	FC 5	150	20
Hitachi	FC 5 A	150	20
Hitachi	FC 5 SA	150	20
Hitachi	FC 5 SA 1	150	20
Hitachi	SA	150	20
Hitachi	SA 1	150	20
Hitachi	C 6	160	20
Hitachi	C 6 DA	160	20
Hitachi	C 60 A	160	20

Art. 100 101 102



	Type	Ø	
Hitachi	DA	160	20
Hitachi	FC 6 A	160	20
Hitachi	FC 6 SA	160	20
Hitachi	FC 65 A	160	20
Hitachi	C 18 DL	165	30
Hitachi	C 6 BU	165	30
Hitachi	C 6 BU2	165	30
Hitachi	C 6 DD-Akku	165	30
Hitachi	C 6 U	165	30
Hitachi	C 6 U2	165	30
Hitachi	C 6 SA	170	30
Hitachi	PSU 6	170	30
Hitachi	FC 7 SA	190	30
Hitachi	PSM 7	190	30
Hitachi	PSU 7	190	30
Hitachi	C 8 FA	210	30
Hitachi	C 8 U	210	30
Hitachi	PSM 8	210	30
Hitachi	PSU 8	210	30
Hitachi	C 9 U	235	30
Hitachi	PSM 9	240	30
Hitachi	PSU 9	240	30
Hitachi	U 210	250	30
Hitachi	C 10 FB	255	30
Hitachi	C 10 FCA	255	30
Hitachi	C 10 RA	255	30
Hitachi	C 13 U	335	30
Hitachi	PSU 13	335	30
Hitachi	C 7 BU	180/184	30
Hitachi	C 7 U	180/184	30
Hitachi	P 7 U	180/184	30
Hitachi	C 8 FC	215/216	30
Hitachi	C 8 FS	215/216	30
Holz-Her	KS 5-1	105	22
Holz-Her	170	140	20
Holz-Her	260	140	20
Holz-Her	270	140	20
Holz-Her	2260	140	20
Holz-Her	2270	140	20
Holz-Her	264	160	20
Holz-Her	1420	160	20
Holz-Her	2103	160	20
Holz-Her	2104	160	20
Holz-Her	2105	160	20
Holz-Her	2106	160	20
Holz-Her	2107	160	20
Holz-Her	2108	160	20
Holz-Her	HKU 264	160	20
Holz-Her	HKU 50	160	20
Holz-Her	HKUS 50	160	20
Holz-Her	281	170	30
Holz-Her	1563	170	30
Holz-Her	2215	170	30
Holz-Her	2266	170	30
Holz-Her	2271	170	30
Holz-Her	2281	170	30
Holz-Her	2115 (t 55a)	170	30
Holz-Her	55 A	170	30
Holz-Her	HKUS 266	170	30
Holz-Her	HKUS 281	170	30
Holz-Her	269	180	30
Holz-Her	272	180	30
Holz-Her	282	180	30
Holz-Her	2112	180	30
Holz-Her	2272	180	30
Holz-Her	2291	180	30
Holz-Her	2292	180	30
Holz-Her	HKU 55	180	30
Holz-Her	HKUS 55	180	30
Holz-Her	2114	190	30
Holz-Her	2116	190	30
Holz-Her	2117	190	30
Holz-Her	2119	190	30
Holz-Her	2126	190	30
Holz-Her	2127	190	30
Holz-Her	2269	190	30
Holz-Her	2282	190	30
Holz-Her	Derby 2214	190	30
Holz-Her	2113	200	30
Holz-Her	2555	200	30
Holz-Her	HK 201	200	30
Holz-Her	284	210	30
Holz-Her	2264	210	30
Holz-Her	2267	210	30
Holz-Her	2284	210	30
Holz-Her	PKS 267	210	30

	Type	Ø	
Holz-Her	Leistsäge 2141	216	30
Holz-Her	274	220	30
Holz-Her	1205	220	30
Holz-Her	1331	220	30
Holz-Her	1342	220	30
Holz-Her	1345	220	30
Holz-Her	1346	220	30
Holz-Her	2274	220	30
Holz-Her	HKU 75	220	30
Holz-Her	PKS 75	220	30
Holz-Her	2118	230	30
Holz-Her	2120	230	30
Holz-Her	2293	230	30
Holz-Her	2294	230	30
Holz-Her	268	240	30
Holz-Her	2268	240	30
Holz-Her	HKD 65	240	30
Holz-Her	HKS 2128	240	30
Holz-Her	275	300	30
Holz-Her	1211	300	30
Holz-Her	1212	300	30
Holz-Her	1213	300	30
Holz-Her	1215	300	30
Holz-Her	1220	300	30
Holz-Her	HKD 85	300	30
Holz-Her	PK 1225	300	30
Holz-Her	PK 1230	300	30
Holz-Her	PKS 1210	300	30
Holz-Her	150	350	30
Holz-Her	276	350	30
Holz-Her	HKS 130	350	30
Holz-Her	277	400	30
Holz-Her	B 7 K	400	30
Holz-Her	HKS 155	400	30
Holz-Her	2171	130/132/134	20
Holz-Her	Derby 2110	130/132/134	20
Holz-Her	Mosquito 2111	130/132/134	20
Holz-Her	2279	210/220	30
INCA	51	150	15
INCA	54	150	15
INCA	Majior	250	20
Jepson	8219	192	20
Jepson	Dry-Miter Cutter 9211 D	255	25,4
Jepson	9312	305	25,4
Jepson	9430	305	25,4
Jepson	Dry-Cutter 9312/E	305	25,4
Jepson	9314	355	25,4
Jepson	9435	355	25,4
Jepson	SuperDry-Cutter 9314	355	25,4
Kango	6235	150	20
Kango	6070	184	16
Kity	511	150	15
Kity	626	150	20
Kity	1611	150	15
Kity	1616	150	15
Kity	510	180	15
Kity	616	180	15
Kity	617	180	15
Kity	2617	180	15
Kity	618	200	30
Kity	0419	200	30
Kity	Junior 6	200	30
Kity	Kombi 2000	200	30
Kity	Kombi 5023	200	30
Kity	KR 419	200	30
Kity	KR 619	200	30
Kity	608	250	30
Kity	609	250	30
Kity	619	250	30
Kity	1609	250	30
Kity	5519	250	30
Kity	5619	250	30
Kity	6619	250	30
Kity	SC 250	250	20
Kity	SCE 1600	250	30
Kity	SCE 250	250	30
Kity	1619	270	30
Kity	9619	270	30
Kity	Formatkreissäge 618/619	270	30
Kity	Kombi 609	270	30
Kity	819	315	30
Kress	6000	150	13
Kress	6006	150	13
Kress	6010	150	13
Kress	6018	150	13

	Type	Ø	
Kress	HKS 400	150	13
Kress	HKS 6006	150	13
Kress	HKS 6018	150	13
Kress	PK 710	150	13
Kress	PK 710 HK	150	13
Kress	XMC 9060	150	13
Kress	6050	160	20
Kress	6055	160	20
Kress	1050 KS	160	20
Kress	6055 a	160	20
Kress	6055 DUO	160	20
Kress	CHKS 6050	160	20
Kress	CHKS 6055	160	20
Kress	DUO Säge	160	20
Kress	HKS 6050	160	20
Kress	6060	190	20
Kress	6066	190	20
Kress	1500 KS	190	20
Kress	1800 KSE	190	20
Kress	6060 b	190	20
Kress	CHKS 6060	190	20
Kress	CHKS 6066	190	20
Kress	HKS 6060 W	190	20
Kress	HTKS 1600	190	20
Kress	KS 1400	190	20
Kress	GS 105	250	30
Kress	GS 90	250	30
Kress	GST 90	250	30
Lamello	Nutfräsen	100	22
Lamello	SF Tanga	150	20
Lamello	Tanga	180	22,23 mm (7/8")
Lutz	KKS 400	315	30
Lutz	LBK	350	30
Lutz	RBK 500	350	30
Lutz	AKS	700	30
Lutz	WKS	700	30
Lutz	ZWS 700	700	30
Mafell	A 35	120	20
Mafell	F 35	120	20
Mafell	FS 35	120	20
Mafell	KSP 40	120	20
Mafell	KSS 300	120	20
Mafell	SF 32 Schattenfugensäge	125	20
Mafell	X 40	125	20
Mafell	XE 40	125	20
Mafell	Biberella	150	13
Mafell	KS 320	160	30
Mafell	KS 330	160	20
Mafell	KSP 55	160	20
Mafell	KSP 55 F	160	20
Mafell	KSS 330	160	20
Mafell	KSS 400	160	20
Mafell	KST 55	160	20
Mafell	MKS 55	160	20
Mafell	MKS 55 F	160	20
Mafell	MS 55	160	20
Mafell	MT 55 cc	160	20
Mafell	PS 52	160	20
Mafell	PSS 3000	160	20
Mafell	PSS 3100 SE	160	20
Mafell	X 55	160	20
Mafell	XE 55	160	20
Mafell	A 55	170	20
Mafell	B 55	170	20
Mafell	FK 50	170	20
Mafell	FU 50	170	20
Mafell	FUS 50	170	20
Mafell	Erika 50	180	30
Mafell	Erika 55	180	30
Mafell	Erika 65	180	30
Mafell	Erika 60	190	30
Mafell	KSP 65	190	30
Mafell	MKS 65	190	30
Mafell	MS 65	190	30
Mafell	B 65	200	30
Mafell	X 72	200	30
Mafell	A 65	210	30
Mafell	FU 65	210	30
Mafell	FUS 65	210	20
Mafell	MKS 75	210	30
Mafell	MS 75	210	30
Mafell	Erika 220	220	30
Mafell	Erika 70 E	225	30
Mafell	MKS 85 S/N	225	30





- 1
- 2
- 3
- 4
- 5
- 6
- 7
- 8
- 9
- 10

	Type	Ø	
Mafell	KSP 85 F	230	30
Mafell	B 82	240	30
Mafell	85 K	250	30
Mafell	Erika 85	250	30
Mafell	Erika 85 K	250	30
Mafell	Erika 85 L	250	30
Mafell	MS 85	250	30
Mafell	A 85	280	30
Mafell	Erika	280	30
Mafell	Erika 65 K	280	30
Mafell	Erika 65 L	280	30
Mafell	Erika 70 L	280	30
Mafell	FS 65	280	30
Mafell	FUS 85	280	30
Mafell	Biborex	315	30
Mafell	FS 85	315	30
Mafell	MKS 102	315	30
Mafell	MKS 105	315	30
Mafell	Monika	315	30
Mafell	TFK 85 K	315	30
Mafell	TFK 85 L	315	30
Mafell	Biber	320	30
Mafell	MKS 125	350	30
Mafell	MSK 125	350	30
Mafell	SF 32	350	30
Mafell	MKS 125 E	355	30
Mafell	MKS 145 E	370	30
Mafell	AZB	400	30
Mafell	BK 3	400	30
Mafell	BSK 4	400	30
Mafell	FKB 150	400	30
Mafell	FS 130	400	30
Mafell	FS 130 K	400	30
Mafell	FS 130 S	400	30
Mafell	TD 3	400	30
Mafell	TDH 4	400	30
Mafell	TDH 425	400	30
Mafell	TK 150	400	30
Mafell	VKS	400	30
Mafell	VKS 130	400	30
Mafell	VKS 160	400	30
Mafell	MKS 165 E	410	30
Mafell	BK	450	30
Mafell	BK 4	450	30
Mafell	BKV 4	450	30
Mafell	BSK 5	450	30
Mafell	FSG 165	450	30
Mafell	FSG 165 K	450	30
Mafell	TDH 450	450	30
Mafell	170	500	30
Mafell	BKV 5	500	30
Mafell	BSK 6	500	30
Mafell	MKS 85	225/250	30
Mafell	TDH 5	450/500	30
Mafell	FSG 200	450/550	30
Mafell	FSG 240 K	450/640	30
Makita	5000 SR	140	16
Makita	4341 S	150	20
Makita	BTK 0	150	20
Makita	5600 NB	160	20
Makita	5600 RDW	160	20
Makita	MKS 55	160	20
Makita	5603K	165	20
Makita	5603RK	165	20
Makita	5604 R	165	20
Makita	BSS610	165	20
Makita	BSS611	165	20
Makita	HS6101	165	20
Makita	SP6000	165	20
Makita	SP6000K	165	20
Makita	SP6000K1	165	20
Makita	SP6000K2	165	20
Makita	SP6000X1	165	20
Makita	5800	180	20
Makita	5500 S	180	20
Makita	5800 B	180	20
Makita	5800 N	180	20
Makita	5800 B	180	20
Makita	5801 B	180	20
Makita	6317 S	180	20
Makita	S 800 BR	180	20
Makita	5017 RKB	190	30
Makita	5703 R	190	30
Makita	5705 R	190	30
Makita	5900 B	235	25
Makita	5903 R	235	30
Makita	2400 B	250	25

	Type	Ø	
Makita	LS 1013	260	25
Makita	LS 1040	260	25
Makita	2402	265	25
Makita	5103 R	270	30
Makita	SR 2600	270	30
Makita	LS 1400	350	25
Makita	BCS550	130/132/134	20
Makita	BSS500	130/132/134	20
Makita	BSS501	130/132/134	20
Makita	5600 B	150/160	20
Makita	5603R	160/165	20
Makita	SR 1600	160/165/180	20
Makita	5600 BR	160/170	20
Makita	4131	180/184	30
Makita	5800 BR	180/184	20
Makita	SR 1800	180/184	20
Makita	5143 R	350/355	30
Maktec	MT580	180/184	20
Meisterkraft	MKR 040 S	160	20
Meisterkraft	MKR 1200	180	20
Metabo	F 0520	100	22
Metabo	6311 S	125	13
Metabo	6311	130	16
Metabo	KS 3340 S	130	16
Metabo	KS 40 S	130	16
Metabo	SHK 01	130	16
Metabo	3340	132	13
Metabo	3342	132	13
Metabo	KS 3342 S	132	13
Metabo	4345 S	140	20
Metabo	C 1	140	20
Metabo	C 2	140	20
Metabo	4340 S	142	13
Metabo	BHK 3	142	13
Metabo	61	150	20
Metabo	62	150	20
Metabo	4341 S	150	20
Metabo	BTK 61+2	150	20
Metabo	BTKOC	150	20
Metabo	KS 0846	150	20
Metabo	KS 0946	150	20
Metabo	KS 0946 S	150	20
Metabo	KS 52	150	20
Metabo	KS 52 S	150	20
Metabo	KS 1155	160	20
Metabo	KS 54	160	20
Metabo	KS 54 SP	160	20
Metabo	KS 55 FS	160	20
Metabo	KSAP 18	160	20
Metabo	KSE 55 Plus	160	20
Metabo	KSE 55 Vario Plus	160	20
Metabo	KSTE 1357 S-Signal	160	20
Metabo	KS 1157 S	165	20
Metabo	KSTE 1357 S	165	20
Metabo	Magnum TK 1256	165	20
Metabo	TK 1256	167	20
Metabo	KS 1185 S	170	20
Metabo	6317 S	180	20
Metabo	SR 1800	180	20
Metabo	5348	190	20
Metabo	46 S	190	20
Metabo	KS 1266 S	190	20
Metabo	KS 1468 S	190	20
Metabo	KS 4345 S	190	20
Metabo	KS 4346 S	190	20/30
Metabo	KS 65 S	190	20
Metabo	KSE 1668 S	190	20
Metabo	TK 5348	190	20
Metabo	KGSE 1670	210	30
Metabo	KGSE 1670 S	210	30
Metabo	KSE 1678 S	210	30
Metabo	TK 1066	210	30
Metabo	TKU 225	210	30
Metabo	6323 S	240	30
Metabo	KS 1785 S	240	30
Metabo	KS 6323 S	240	30
Metabo	THU 1693 D	250	30
Metabo	TKU 1633	250	30
Metabo	TKU 1633 D	250	30
Metabo	TKU 1693	250	30
Metabo	TKU 1693 D	250	30
Metabo	4340	125/130	13/16
Metabo	BHK 1	125/130/132	13/16
Metabo	Max	130/132	13/16
Metabo	BHK 2	130/142	13/16
Metabo	BTK 0	140/150	20

	Type	Ø	
Metabo	BTK	140/160	20
Metabo	KS 0846 S	150/152	20
Metabo	KS 0852 S	150/152	20
Metabo	KSE 0946 S	150/152	20
Metabo	KST 1157 S	165/167	20
Metabo	KST 1357 S	165/167	20
Metabo	BTK 1	165/167/170	20
Metabo	KS 1155 S	165/167/170	20
Metabo	6322 S	220/240	30
Metabo	1688 Magnum	250/300/315	30
Metabo	TK 1685	250/300/315	30
Metabo	TK 1685 D	250/300/315	30
Metabo	TK 1688 D	250/300/315	30
Metabo	TK 168 S	250/300/315	30
Metalkraft	EVO 180	180	20
Metalkraft	EVO 180 Xtreme	180	20
Milwaukee	CS 55	165	30
Milwaukee	V28 MS	170/174	20
Narex	EPK 16 D	160	20
Nutool	EPK 16	160	20
Omega	Diverse	250 - 240	30
Panasonic	EY 3501	110	20
Panasonic	EY 3530	135	20
Panasonic	EY3551GOW	165	20
Panasonic	EY3552GOW	165	20
Panasonic	EY3530NQMKW	130/132/134	20
Parkside	PAHKS 18 V	140	10
Performance Power	110 W	160	20
Perles	25 S	100	12
Perles	SC 47 C	140	20
Perles	KS 50	150	20
Perles	KS 51 Chroma	150	20
Perles	Peugeot	150	20
Perles	SC 53 C	150	20
Perles	KS 55 (ab 2007 oder 2008)	160	20
Perles	KS 55 (bis 2007)	160	16
Perles	6317 S	180	20
Perles	FIP 50 S	180	20
Perles	SR 1800	180	20
Peugeot	25 S	100	12
Peugeot	25 SL	100	12
Peugeot	SC 1	132	13
Peugeot	HKS 700	140	20
Peugeot	Proffline	140	20
Peugeot	SC 3	140	12,7 (1/2")
Peugeot	SC 47 C	140	20
Peugeot	TC 3008	140	20
Peugeot	SC 46	150	20
Peugeot	SC 52	150	20
Peugeot	SC 52 C	150	20
Peugeot	SC 52 S	150	20
Peugeot	SC 53 C	150	20
Peugeot	TC 3009	150	20
Peugeot	SC 55010 XA	170	16
Peugeot	FIP 20 S	180	20
Peugeot	FIP 50	180	20
Peugeot	FIP 50 S	180	20
Peugeot	TC 3017	190	30
Peugeot	TC 3014	200	30
Peugeot	SC 86010 XA	235	16
Peugeot	SC 42 C	130/132/134	20
Peugeot	SC 42 C-H	130/132/134	20
Peugeot	SC 4510 XA	160/165	16
Peugeot	10 XA	180/184	16
Peugeot	SC 65 C	180/184	16
Peugeot	SC 660	180/184	16
Peugeot	SC 65010 XA	180/184	16
Peugeot	SC 66 C	180/184	16
Peugeot	SC 66 C-H	180/184	16
Powerplus	POW 1041P	140	16
Powerplus	POW 104	160	20
Powerplus	POW 1043	160	20
Powerplus	POW 1044	180/184	20
Powerplus	POW X052	180/184	20
Powerplus	POW X142	180/184	20
Powerplus	POW X05313	180/184	20
Prostar	HKS 1400	140	20
Protool	CSP 55-1	160	20
Protool	CSP 55-2	160	20
Protool	CSP 56 EQ	160	20
Protool	CSP 56-2 EB	160	20
Protool	CSP 56-Q	160	20
Protool	CSP 68	160	20
Proviel	HHK 1400	140	20
Proviel	HHK 1805	184	16



MASCHINENHERSTELLER ALPHABETISCH MIT PASSENDEM BLATT-Ø + BOHRUNG
 MACHINE MANUFACTURER IN ALPHABETICAL ORDER WITH MATCHING BLADE-Ø + BORE-Ø

Karnasch®

	Type	Ø	
Proviel	HTK 1000	200	16
Proviel	HTS 600	200	16
Proviel	WWT 1000	200	16
Proviel	HKF 205	205	18
Proviel	HKG 210	210	30
Robland	K 210-260	240	30
Robland	X 260	250	30
Robland	K 310	300	30
Robland	X 310	300	30
Rockwell	346	165	16
Rockwell	315	184	16
Rockwell	4500	184	16
Rockwell	368 Bohrung 20 mm	210	30
Rockwell	63418 Bohrung 20 mm	210	30
Rockwell	368	220	20
Rockwell	63418	220	20
Rockwell	63416	165/170	16
Rockwell	63417	180/184	16
Ryobi	CCS1801/DM	150	10
Ryobi	CCS1801/LM	150	10
Ryobi	LCS180	150	10
Ryobi	W-5502	160	20
Ryobi	W-5503	160	16
Ryobi	W-560	160	20
Ryobi	W-560 P	160	20
Ryobi	B 6402	180	20
Ryobi	W-6502	180	20
Ryobi	W-651	180	20
Ryobi	W-651 A	180	20
Ryobi	W-651 P	180	20
Ryobi	W-66 N	180	20
Ryobi	HW 600	180/184	16
Ryobi	W 640 C	180/184	16
Ryobi	W 640 NCI	180/184	16
Ryobi	W 6402 C	180/184	16
Ryobi	W 6402 NC	180/184	16
Ryobi	W 6403 C	180/184	16
Ryobi	W 6403 NC	180/184	16
Ryobi	W 660	180/184	16
Ryobi	W 6601	180/184	16
Ryobi	W 6602	180/184	16
Scheer	HM 5	100	22
Scheer	HM 6	100	22
Scheer	MS 45	150	20
Scheer	MS 45 E	150	20
Scheer	MS 45-3	150	20
Scheer	MS 50	150	16
Scheer	FM (160 mm-Ausführung)	160	16
Scheer	M 55	160	20
Scheer	MS 55	160	20
Scheer	FM (180 mm-Ausführung)	180	16
Scheer	MS 65	190	30
Scheer	MS 70	200	30
Scheer	MS 80	220	30
Scheer	FM-10A-3100-4200	240	30
Scheer	MS 85	220/230	30
Scheppach	KG 205 E	200	30
Scheppach	KSE 250	200	30
Scheppach	TS 2000	200	30
Scheppach	KG 205	205	18
Scheppach	Capas 1	216	30
Scheppach	Capas 2	216	30
Scheppach	KG 250	250	20
Scheppach	KG 260 E	250	30
Scheppach	KG 280 E	250	30
Scheppach	TKG 250	250	20
Scheppach	TKG 260 E	250	30
Scheppach	TKG 280 E	250	30
Scheppach	TS 2500	250	30
Scheppach	KSE 300 (Export)	300	30
Scheppach	TK	300	30
Scheppach	TKH	300	30
Scheppach	TKU	300	30
Scheppach	TS 4000	300	30
Scheppach	Capas 3	305	30
Scheppach	TKG 305 E	305	30
Scheppach	Forsato XL/XXL	315	30
Scheppach	TS 315	315	30
Scheppach	TS 315 GT	315	30
Scheppach	TS 4010	315	30
Scheppach	XXL	315	30
Scheppach	BS 500	400	30
Scheppach	BSH 400	400	30
Scheppach	BSH 500	400	30

	Type	Ø	
Schleicher	300	180	12,7 (1/2")
Schleicher	310	250	30
Schleicher	330	300	30
Skil/Skilsaw/-Masters	5140	130	16
Skil/Skilsaw/-Masters	5240	130	16
Skil/Skilsaw/-Masters	5740	130	16
Skil/Skilsaw/-Masters	532	142	13
Skil/Skilsaw/-Masters	1800	150	20
Skil/Skilsaw/-Masters	1850	150	20
Skil/Skilsaw/-Masters	5246	150	16
Skil/Skilsaw/-Masters	1800 H	150	20
Skil/Skilsaw/-Masters	1850 H	150	20
Skil/Skilsaw/-Masters	1850 HD	150	20
Skil/Skilsaw/-Masters	367	160	16
Skil/Skilsaw/-Masters	534	160	16
Skil/Skilsaw/-Masters	536	160	16
Skil/Skilsaw/-Masters	856	160	16
Skil/Skilsaw/-Masters	1854	160	16
Skil/Skilsaw/-Masters	5750	160	16
Skil/Skilsaw/-Masters	5855	160	16
Skil/Skilsaw/-Masters	1440 H	160	16
Skil/Skilsaw/-Masters	1854 U	160	16
Skil/Skilsaw/-Masters	1855 H	160	16
Skil/Skilsaw/-Masters	1855 U	160	16
Skil/Skilsaw/-Masters	416 H	160	16
Skil/Skilsaw/-Masters	552 B	160	16
Skil/Skilsaw/-Masters	552 H	160	16
Skil/Skilsaw/-Masters	5750 A	160	16
Skil/Skilsaw/-Masters	416 H 1	165	16
Skil/Skilsaw/-Masters	1410 H 2	170	16
Skil/Skilsaw/-Masters	1522 H	170	20
Skil/Skilsaw/-Masters	1522 U	170	16
Skil/Skilsaw/-Masters	416 H 2	170	16
Skil/Skilsaw/-Masters	5055 MA	170	16
Skil/Skilsaw/-Masters	5164 A	184	16
Skil/Skilsaw/-Masters	1866	190	16
Skil/Skilsaw/-Masters	5266	190	16
Skil/Skilsaw/-Masters	5565	190	16
Skil/Skilsaw/-Masters	5566	190	16
Skil/Skilsaw/-Masters	5666	190	16
Skil/Skilsaw/-Masters	1965 U	190	30
Skil/Skilsaw/-Masters	5266 UG	190	16
Skil/Skilsaw/-Masters	5866 A	190	16
Skil/Skilsaw/-Masters	1524 H	210	30
Skil/Skilsaw/-Masters	1526 H	210	30
Skil/Skilsaw/-Masters	1873 H	210	30
Skil/Skilsaw/-Masters	1525 H	235	30
Skil/Skilsaw/-Masters	1886 H	235	30
Skil/Skilsaw/-Masters	1985 U	235	30
Skil/Skilsaw/-Masters	1986 U	235	30
Skil/Skilsaw/-Masters	1523 H	260	30
Skil/Skilsaw/-Masters	1899 H	260	30
Skil/Skilsaw/-Masters	22501 B	125/127	12,7 (1/2")
Skil/Skilsaw/-Masters	533	142/150	13
Skil/Skilsaw/-Masters	553	142/150	13
Skil/Skilsaw/-Masters	1408 H	160/165	16
Skil/Skilsaw/-Masters	1408 N	160/165	16
Skil/Skilsaw/-Masters	1409 H	160/165	16
Skil/Skilsaw/-Masters	1410 H	160/165	16
Skil/Skilsaw/-Masters	77	180/184	16
Skil/Skilsaw/-Masters	537	180/184	16
Skil/Skilsaw/-Masters	559	180/184	16
Skil/Skilsaw/-Masters	857	180/184	16
Skil/Skilsaw/-Masters	1865	180/184	16
Skil/Skilsaw/-Masters	1865 H	180/184	16
Skil/Skilsaw/-Masters	1865 U	180/184	16
Skil/Skilsaw/-Masters	553 B	180/184	16
Skil/Skilsaw/-Masters	553 BIH	180/184	16
Skil/Skilsaw/-Masters	553 H	180/184	16
Skil/Skilsaw/-Masters	559 U	180/184	16
Skil/Skilsaw/-Masters	574 U	180/184	16
Skil/Skilsaw/-Masters	77 U	180/184	16
Smalcalda/DDR	H 162	160	25
Smalcalda/DDR	H 165	160	25
Smalcalda/DDR	HKS 160	160	25
Smalcalda/DDR	HKS 160 A	160	25
Smalcalda/DDR	KS 35	160	25
Smalcalda/DDR	ZHK 250	160	25
Smalcalda/DDR	ZHK 43	160	25
Smalcalda/DDR	ZHK 45	160	25
Smalcalda/DDR	ZHT 43	160	25
Smalcalda/DDR	ZHT 45	160	25
Smalcalda/DDR	ZTK 43	160	25
Smalcalda/DDR	ZTK 450	160	25
Stanley	H 272	180/184	16
Stanley	H 273	180/184	16

	Type	Ø	
Stayer	CP 46	140	20
Stayer	HKS 700	140	20
Stayer	Proflite	140	20
Stayer	SC 47 C	140	20
Stayer	CP 50	150	20
Stayer	KS 700	205	18
Stayer	SC 205	205	18
Stayer	TKS 2000	205	18
Stayer	Kapp-Gehrung	250	30
Stayer	SC 250	250	20
Stayer	SC 251	250	20
Stayer	SC 260	250	30
Stayer	SCE 1610	250	30
Stayer	SCE 250	250	30
Stayer	SCU 74	250	20
Stayer	SII 250	250	30
Stayer	TD 305	305	25,4
Striebig	Plattensäge	250	30
Striebig	Plattensäge	300	30
Tecline	EHS 160	160	20
TIP	HKS 160	160	20
TIP	HKS 161	160	20
TIP	HKS 200	200	16
Ulmia	Universa	125	16
Ulmia	KS 1	150	30
Ulmia	1607	160	16
Ulmia	1610	160	16
Ulmia	1409 B	160	16
Ulmia	1706	200	30
Ulmia	1708	200	30
Ulmia	US 1	200	30
Ulmia	1622	250	20
Ulmia	1625	250	20
Ulmia	1710 R	250	30
Ulmia	1710 S	250	30
Ulmia	1612	300	30
Ulmia	1711	300	30
Ulmia	KS 300	300	30
Ulmia	1712	350	30
Ulmia	1728	350	30
Ulmia	1729	350	30
Ulmia	1712 R	350	30
Ulmia	KS 350	350	30
Uniropa (Quelle)	HKS 6050	160	20
Uniropa (Quelle)	HKS 6055	160	20
Wegoma	TB 204	105	22
Wegoma	HS 50	150	20
Wegoma	RZ270S	160	20
Wegoma	TS160	160	20
Wegoma	TS160M	160	20
Wegoma	TS230	230	30
Wegoma	TS230M	230	30
Wegoma	KG548	250	30
Wegoma	KG548T	250	30
Wegoma	TS 250	250	32
Wegoma	KG533	300	30
Wegoma	KG533T	300	30
Wegoma	KG572	300	30
Wegoma	KG572T	300	30
Wegoma	FKS	315	30
Wegoma	S315	315	30
Wegoma	S315ECO	315	30
Wegoma	S 4 D	350	30
Wegoma	S 4 W	350	30
Wegoma	S400	400	30
Wegoma	S400ECO	400	30
Wegoma	S400NC	400	30
Wegoma	TS 400	400	30
Wolf	6070	180/184	16



Art.
100
101
102

Stahl Steel

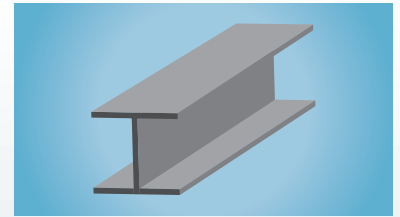

Dünnschnitt-Kreissägen für Produktionsmaschinen wie von:
 Thin-section circular saws for production machines, e.g. from:

ADIGE, BEHRINGER-EISELE,
 BEWO, DELTA, EVERISING,
 EXACT-CUT, FICEP, GERNETTI,
 ITEC, KALTENBACH, KASTO,
 MAGA, NISHIJIMA-SIMAX,
 RATTUNDE, RSA, SINICO, TSUNE

532/533

Kreissägen für industrielle Großsägen, Produktionsmaschinen wie von:
 Circular saws for large industrial production machines such as:

FRAMAG, LINSINGER, MFL

535

Schnittwertempfehlungen · Recommended cutting values

Werkstoffgruppe Material Group	DIN	Werkstoff-Nr. Material number	Vc (m/min) Schnittgeschwindigkeit Cutting speed	fz (mm/z) Vorschub pro Zahn Feed per tooth
Baustähle Structural steels	St 37/42	1.0037 / 1.0042	130 - 150	0,06 - 0,07
	St 52/60	1.0050 / 1.0060	100 - 120	0,06 - 0,07
Einsatzstähle Case hardened steels	C 10/C 15	1.0301 / 1.0401	130 - 150	0,06 - 0,07
	16 MnCr 5	1.7131	100 - 120	0,06 - 0,07
	20CrMo5	1.7264	100 - 120	0,06 - 0,07
	21NiCrMo2	1.6523	100 - 120	0,06 - 0,07
Nitrierstähle Nitriding steels	34CrAlNi 7	1.8550	90 - 100	0,06 - 0,07
	34 CrAlMo 5	1.8507	90 - 100	0,06 - 0,07
Automatenstähle Machining steels	9 S 20	1.0711	130 - 150	0,06 - 0,07
	9SMn28	1.0718	130 - 150	0,06 - 0,07
Vergütungsstähle Quenched and tempered steels	C35/C45	1.051 / 1.0503	100 - 120	0,06 - 0,07
	42CrMo4	17225	90 - 100	0,05 - 0,06
	34 CrNiMo 6	1.6582	90 - 100	0,05 - 0,06
Wälzlagerstähle Ball bearing steels	115CrV3	12210	70 - 90	0,05 - 0,06
	100Cr6	13505	70 - 90	0,05 - 0,06
Federstahl Spring steel	65 Si 7	15028	80 - 90	0,05 - 0,06
	50CrV 4	18159	80 - 90	0,05 - 0,06
Werkzeugstähle Tool steel	C125W	11663	70 - 90	0,05 - 0,06
	40CrMnMo7	12311	70 - 90	0,05 - 0,06
	X 40 CrMoV 51	12344	60 - 90	0,04 - 0,05
	X 155 CrVMo 12 1	12379	60 - 80	0,04 - 0,05
Schnellarbeitsstähle High-speed steels	S6-5-2	13343	70 - 90	0,04 - 0,05
	b-10-1-8	13247	70 - 90	0,04 - 0,05
Rost- und säurebeständige Stähle Stainless steel	x20Cr13	14021	50 - 90	0,04 - 0,05
	X 5CrNi 1810	14301	50 - 80	0,04 - 0,05
	X 6 CrNiMoTi 17122	14571	50 - 70	0,04 - 0,05
Kaltfließpressstahl Cold forging steel	38Cr2	17003	60 - 100	0,04 - 0,05
	37Cr4	17034	80 - 100	0,04 - 0,05
Vergütete Stähle Tempered steels	1200-1400 N/mm	-	70 - 90 60 - 80	0,04 - 0,05 0,04 - 0,05

Festlegung der Schnittgeschwindigkeit Vc
 Determination of cutting speed Vc

$$Vc \text{ (m/min)} = \frac{D \cdot \pi \cdot n}{1000}$$

Festlegung der Vorschubgeschwindigkeit Vf
 Determination of feed rate Vf

$$Vf \text{ (mm/min)} = fz \cdot n \cdot Z$$

Festlegung der Drehzahl n
 Determination

$$n \text{ (min}^{-1}\text{)} = \frac{Vc \cdot 1000}{D \cdot \pi}$$



fz (mm/z) = Vorschub pro Zahn · Feed per tooth
 D (mm) = Sägendurchmesser · Saw blade diameter
 Z = Anzahl der Zähne · Number of teeth
 n (min⁻¹) = Drehzahl · rpm

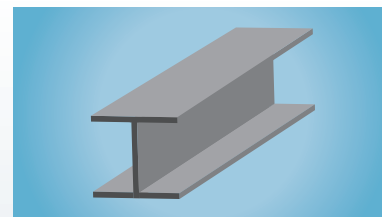

Art.
100
101
102

Stahl
Steel

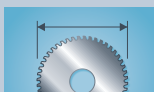

Art. Ø mm	Type	Anwendung · Application	
10.7000 Ø mm 250-460 	Dünnschnitt-Stahlsägen Cermet	Für Kreissägeautomaten mit Sägeblattstabilisatoren	532
	Thin-Cut steel saws Cermet	For circular saw machines with saw blade stabilisers	
10.7001 Ø mm 250-460 	Dünnschnitt-Stahlsägen Hartmetall-bestückt	Für Kreissägeautomaten mit Sägeblattstabilisatoren	533
	Thin-Cut steel saws Carbide tipped	For circular saw machines with saw blade stabilisers	
10.7050 Ø mm 250-1560 	Hochleistungs-Stahlsägen	Für Kreissägeautomaten / stabile Maschinen wie z.B. FRAMAG, LINSINGER, MFL	535
	High-Performance steel saws	For circular saw machines / stable production machines such as FRAMAG, LINSINGER, MFL	

1



2



3



4



5



6



7



8



9



10



Art.
100
101
102

Art. **10.7000**

Dünnschnitt-Stahlsägen Cermet
Thin-Cut steel saws Cermet

GOLD-STAR LINE 

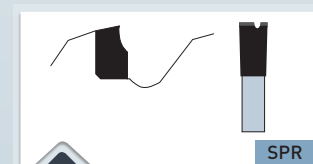

CERMET-Zähne

CERMET teeth

SPR

- > Spezialgeometrie mit Spanteilerillen
- > Special geometry with chip breaker

MASCHINE · MACHINE

Für Kreissägeautomaten mit Sägeblattstabilisator wie: ADIGE, BEHRINGER-EISELE, BEWO, DELTA, EVERISING, EXACT-CUT, FICEP, GERNETTI, ITEC, KALTENBACH, KASTO, MAGA, NISHIJIMA-SIMAX, RATTUNDE, RSA, SINICO, TSUNE

For circular saw machines with saw blade stabilisers, such as: ADIGE, BEHRINGER-EISELE, BEWO, DELTA, EVERISING, EXACT-CUT, FICEP, GERNETTI, ITEC, KALTENBACH, KASTO, MAGA, NISHIJIMA-SIMAX, RATTUNDE, RSA, SINICO, TSUNE



FÜR DIE ABGABE EINES ANGEBOTES BENÖTIGEN WIR FOLGENDE

ANGABEN: Abmessung, Stückzahl, DIN-Normbezeichnung des zu sägenden Materials, die Abmessung des zu sägenden Materials, Vorschub, Maschinentyp. Falls vorhanden Zeichnung der Schneidengeometrie oder Musterblatt.

WE REQUIRE THE FOLLOWING INFORMATION FOR DELIVERY OF AN

ORDER: Dimensions, Quantity, DIN standard designation of the material to be cut, the dimensions of the material to be cut, Feed, machine type, diagram of the cutting geometry or sample blade, if available.





✓ OPTIMAL · OPTIMAL ✓ GUT · GOOD ✓ MÖGLICH · POSSIBLE

✓		Baustahl	Mild steel
✓		Edelstahl	Stainless steel
✓		Ne-Metall wie Alu, Messing, Kupfer	Non ferrous materials like alu, copper, brass

ANWENDUNG · APPLICATION

Zum Sägen von Stahl, Edelstahl, NE-Metallen wie Alu, Kupfer, Messing u.ä.

For cutting steel, high-grade steel, non-ferrous metals, such as aluminium, copper, brass, etc.

Art.	Maschinenhersteller Machine manufacturers						€
107000.250.010	Tsune, Kasto, Nichijima, Everising	○ 250	2,0/1,75	32	54	4-9-50 / 4-11-63	-
107000.250.020		○ 250	2,0/1,75	32	60	4-9-50 / 4-11-63	-
107000.250.030		○ 250	2,0/1,75	32	72	4-9-50 / 4-11-63	-
107000.250.040	Bewo, Pfeiffner	○ 250	2,0/1,75	32	80	4-9-50 / 4-11-63	-
107000.250.050		○ 250	2,0/1,75	40	54	2-8,5-55 / 4-12-64	-
107000.250.060		○ 250	2,0/1,75	40	60	2-8,5-55 / 4-12-64	-
107000.250.070		○ 250	2,0/1,75	40	72	2-8,5-55 / 4-12-64	-
107000.250.080		○ 250	2,0/1,75	40	80	2-8,5-55 / 4-12-64	-
107000.285.010	Tsune, Kasto, Nichijima, I.T.E.C, Dualcut	○ 285	2,0/1,75	32	54	4-9-50 / 4-11-63	-
107000.285.020		○ 285	2,0/1,75	32	60	4-9-50 / 4-11-63	-
107000.285.030		○ 285	2,0/1,75	32	72	4-9-50 / 4-11-63	-
107000.285.040		○ 285	2,0/1,75	32	80	4-9-50 / 4-11-63	-
107000.285.050		○ 285	2,0/1,75	40	54	4-12-64 / 4-11-80	-
107000.285.060	Everising, Amada, Bewo, Noritake	○ 285	2,0/1,75	40	60	4-12-64 / 4-11-80	-
107000.285.070		○ 285	2,0/1,75	40	72	4-12-64 / 4-11-80	-
107000.285.080		○ 285	2,0/1,75	40	80	4-12-64 / 4-11-80	-
107000.315.010	Kasto, Kentaki	○ 315	2,25/2,0	32	60	4-9-50	-
107000.315.020		○ 315	2,25/2,0	32	72	4-9-50	-
107000.315.030		○ 315	2,25/2,0	32	80	4-9-50	-
107000.315.040	Behringer	○ 315	2,25/2,0	40	80	2-15-80	-
107000.360.010	Everising, Amada, Noritake, Behringer, Mega, Missler	○ 360	2,6/2,25	40	60	4-15-80 / 4-11-90	-
107000.360.020		○ 360	2,6/2,25	40	72	4-15-80 / 4-11-90	-
107000.360.030		○ 360	2,6/2,25	40	80	4-15-80 / 4-11-90	-
107000.360.040		○ 360	2,6/2,25	40	100	4-15-80 / 4-11-90	-
107000.360.050	Tsune, Kasto, Kaltenbach, Nichijima, Endo, Rattunde	○ 360	2,6/2,25	50	60	4-15-80 / 4-11-90	-
107000.360.060		○ 360	2,6/2,25	50	72	4-15-80 / 4-11-90	-
107000.360.070		○ 360	2,6/2,25	50	80	4-15-80 / 4-11-90	-
107000.360.080		○ 360	2,6/2,25	50	100	4-15-80 / 4-11-90	-
107000.425.010	Tsune, Kasto	○ 425/420	2,6/2,25	50	60	4-15-80 / 4-11-90	-
107000.425.020		○ 425/420	2,6/2,25	50	80	4-15-80 / 4-11-90	-
107000.425.030		○ 425/420	2,6/2,25	50	100	4-15-80 / 4-11-90	-
107000.460.010	Amada, Everising, Nichijima, Noritake	○ 460	2,7/2,25	50	60	4-15-80 / 4-11-90	-
107000.460.020		○ 460	2,7/2,25	50	80	4-15-80 / 4-11-90	-
107000.460.030		○ 460	2,7/2,25	50	100	4-15-80 / 4-11-90	-

Weitere Abmessungen auf Anfrage
Other dimensions are available on request



Video



1

2

3

4

5

6

7

8

9

10

Art.
100
101
102

Dünnschnitt-Stahlsägen Hartmetall-bestückt
Thin-Cut steel saws carbide tipped

Art. **10.7001**

GOLD-STAR LINE

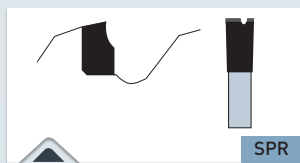

Hartmetall-Zähne +
TIALN-beschichtet

Carbide teeth +
TIALN-coated

SPR

- > Spezialgeometrie mit Spanteilerrillen
- > Special geometry with chip breaker

MASCHINE · MACHINE

Für Kreissägeautomaten mit Sägeblattstabilisator wie: ADIGE, BEHRINGER-EISELE, BEWO, DELTA, EVERISING, EXACT-CUT, FICEP, GERNETTI, ITEC, KALTENBACH, KASTO, MAGA, NISHIJIMA-SIMAX, RATTUNDE, RSA, SINICO, TSUNE

For circular saw machines with saw blade stabilisers, such as: ADIGE, BEHRINGER-EISELE, BEWO, DELTA, EVERISING, EXACT-CUT, FICEP, GERNETTI, ITEC, KALTENBACH, KASTO, MAGA, NISHIJIMA-SIMAX, RATTUNDE, RSA, SINICO, TSUNE

FÜR DIE ABGABE EINES ANGEBOTES BENÖTIGEN WIR FOLGENDE

ANGABEN: Abmessung, Stückzahl, DIN-Normbezeichnung des zu sägenden Materials, die Abmessung des zu sägenden Materials, Vorschub, Maschinentyp. Falls vorhanden Zeichnung der Schneidengeometrie oder Musterblatt.

WE REQUIRE THE FOLLOWING INFORMATION FOR DELIVERY OF AN

ORDER: Dimensions, Quantity, DIN standard designation of the material to be cut, the dimensions of the material to be cut, Feed, machine type, diagram of the cutting geometry or sample blade, if available.

- ✓ OPTIMAL · OPTIMAL
- ✓ GUT · GOOD
- ✓ MÖGLICH · POSSIBLE

✓		Baustahl	Mild steel
✓		Edelstahl	Stainless steel
✓		Ne-Metall wie Alu, Messing, Kupfer	Non ferrous materials like alu, copper, brass

ANWENDUNG · APPLICATION

Zum Sägen von Stahl, Edelstahl, NE-Metallen wie Alu, Kupfer, Messing u.ä.

For cutting steel, high-grade steel, non-ferrous metals, such as aluminium, copper, brass, etc.

Art.	Maschinenhersteller Machine manufacturers						€
107001.250.010	Tsune, Kasto, Nichijima, Everising	○ 250	2,0/1,75	32	54	4-9-50 / 4-11-63	-
107001.250.020		○ 250	2,0/1,75	32	60	4-9-50 / 4-11-63	-
107001.250.030		○ 250	2,0/1,75	32	72	4-9-50 / 4-11-63	-
107001.250.040	Bewo, Pfeiffner	○ 250	2,0/1,75	32	80	4-9-50 / 4-11-63	-
107001.250.050		○ 250	2,0/1,75	40	54	2-8,5-55 / 4-12-64	-
107001.250.060		○ 250	2,0/1,75	40	60	2-8,5-55 / 4-12-64	-
107001.250.070		○ 250	2,0/1,75	40	72	2-8,5-55 / 4-12-64	-
107001.250.080		○ 250	2,0/1,75	40	80	2-8,5-55 / 4-12-64	-
107001.285.010	Tsune, Kasto, Nichijima, I.T.E.C, Dualcut	○ 285	2,0/1,75	32	54	4-9-50 / 4-11-63	-
107001.285.020		○ 285	2,0/1,75	32	60	4-9-50 / 4-11-63	-
107001.285.030		○ 285	2,0/1,75	32	72	4-9-50 / 4-11-63	-
107001.285.040		○ 285	2,0/1,75	32	80	4-9-50 / 4-11-63	-
107001.285.050		○ 285	2,0/1,75	40	54	4-12-64 / 4-11-80	-
107001.285.060	Everising, Amada, Bewo, Noritake	○ 285	2,0/1,75	40	60	4-12-64 / 4-11-80	-
107001.285.070		○ 285	2,0/1,75	40	72	4-12-64 / 4-11-80	-
107001.285.080		○ 285	2,0/1,75	40	80	4-12-64 / 4-11-80	-
107001.315.010	Kasto, Kentaki	○ 315	2,25/2,0	32	60	4-9-50	-
107001.315.020		○ 315	2,25/2,0	32	72	4-9-50	-
107001.315.030		○ 315	2,25/2,0	32	80	4-9-50	-
107001.315.040	Behringer	○ 315	2,25/2,0	40	80	2-15-80	-
107001.360.010	Everising, Amada, Noritake, Behringer, Mega, Missler	○ 360	2,6/2,25	40	60	4-15-80 / 4-11-90	-
107001.360.020		○ 360	2,6/2,25	40	72	4-15-80 / 4-11-90	-
107001.360.030		○ 360	2,6/2,25	40	80	4-15-80 / 4-11-90	-
107001.360.040		○ 360	2,6/2,25	40	100	4-15-80 / 4-11-90	-
107001.360.050	Tsune, Kasto, Kaltenbach, Nichijima, Endo, Rattunde	○ 360	2,6/2,25	50	60	4-15-80 / 4-11-90	-
107001.360.060		○ 360	2,6/2,25	50	72	4-15-80 / 4-11-90	-
107001.360.070		○ 360	2,6/2,25	50	80	4-15-80 / 4-11-90	-
107001.360.080		○ 360	2,6/2,25	50	100	4-15-80 / 4-11-90	-
107001.425.010	Tsune, Kasto	○ 425/420	2,6/2,25	50	60	4-15-80 / 4-11-90	-
107001.425.020		○ 425/420	2,6/2,25	50	80	4-15-80 / 4-11-90	-
107001.425.030		○ 425/420	2,6/2,25	50	100	4-15-80 / 4-11-90	-
107001.460.010	Amada, Everising, Nichijima, Noritake	○ 460	2,7/2,25	50	60	4-15-80 / 4-11-90	-
107001.460.020		○ 460	2,7/2,25	50	80	4-15-80 / 4-11-90	-
107001.460.030		○ 460	2,7/2,25	50	100	4-15-80 / 4-11-90	-

Weitere Abmessungen auf Anfrage
Other dimensions are available on request



Video

533



Art.
100
101
102



Art. **10.7050**

Hochleistungs-Stahlsägen
High-Performance steel saws

GOLD-STAR LINE 



✓ OPTIMAL · OPTIMAL ✓ GUT · GOOD ✓ MÖGLICH · POSSIBLE

✓		Baustahl	Mild steel
✓		Edelstahl	Stainless steel
✓		Schienen	Rails

ANWENDUNG · APPLICATION

Zum Sägen von Stahl, Edelstahl, Eisenbahnschienen. Profile und Vollmaterial

For cutting steel, stainless steel, rails. Profiles and solid material

FÜR DIE ABGABE EINES ANGEBOTES BENÖTIGEN WIR FOLGENDE ANGABEN:

Abmessung, Stückzahl, DIN-Normbezeichnung des zu sägenden Materials, die Abmessung des zu sägenden Materials, Vorschub, Maschinentyp. Falls vorhanden Zeichnung der Schneidengeometrie oder Musterblatt.

WE REQUIRE THE FOLLOWING INFORMATION FOR DELIVERY OF AN ORDER:

Dimensions, Quantity, DIN standard designation of the material to be cut, the dimensions of the material to be cut, Feed, machine type, diagram of the cutting geometry or sample blade, if available.

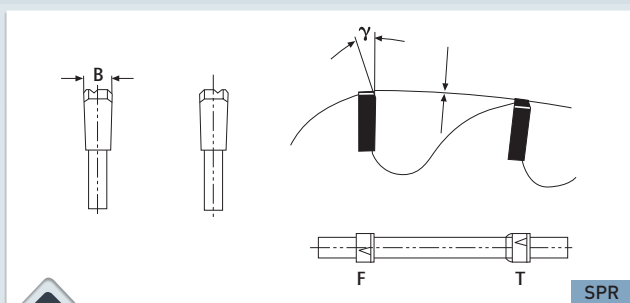

SPR

- > Universalverzahnung für Profile und Vollmaterial
- > Universal toothing for profiles and solid material

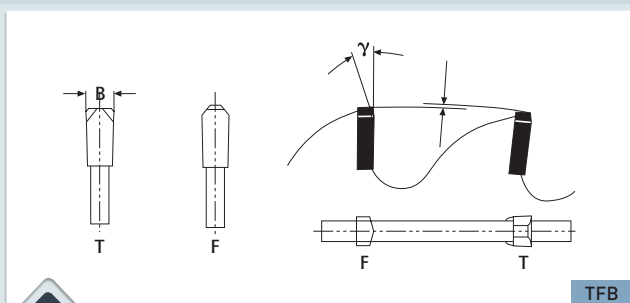

TFB

- > Spezialverzahnung für Vollmaterial
- > Special toothing for solid material

MASCHINE · MACHINE

Für Kreissägeautomaten / stabile Maschinen wie z.B. FRAMAG, LINSINGER, MFL auf denen HM-Bestückte Kreissägen eingesetzt werden können.





- Material muss vibrationsfrei gespannt sein
- Umfangsgeschwindigkeit für Vollmaterial je nach Materialgüte 80-140 m/min erforderlich
Stufenlos regelbarer Vorschub von 0,2-0,4 m/min
- Umfangsgeschwindigkeit bei Profile: Je nach Profil- oder Rohrstärke 110-160 m/min erforderlich
Stufenlos regelbarer Vorschub von 0,2-0,8 m/min.

For circular saw machines / stable production machines such as FRAMAG, LINSINGER, MFL on which T.C tipped tools can be installed.

- The material has to be fixed without causing vibrations
- Rotational speed for solid material depending on the material quality 80-140 m/min required
Infinitely adjustable feed rate of 0.2-0.4 m/min
- Rotational speed for profiles: Depending on the profile or tube thickness 110-160 m/min required
Infinitely adjustable feed rate of 0.2-0.8 m/min.



Hochleistungs-Stahlsägen
High-Performance steel saws

					€
○ 250	3,5/2,5	Auf Anfrage/On request	Auf Anfrage/On request	Auf Anfrage/On request	-
○ 280	3,5/2,5	Auf Anfrage/On request	Auf Anfrage/On request	Auf Anfrage/On request	-
○ 315	4,0/3,0	Auf Anfrage/On request	Auf Anfrage/On request	Auf Anfrage/On request	-
○ 350	4,5/3,5	Auf Anfrage/On request	Auf Anfrage/On request	Auf Anfrage/On request	-
○ 360	4,5/3,5	Auf Anfrage/On request	Auf Anfrage/On request	Auf Anfrage/On request	-
○ 400	4,5/3,5	Auf Anfrage/On request	Auf Anfrage/On request	Auf Anfrage/On request	-
○ 420	4,5/3,5	Auf Anfrage/On request	Auf Anfrage/On request	Auf Anfrage/On request	-
○ 425	4,5/3,5	Auf Anfrage/On request	Auf Anfrage/On request	Auf Anfrage/On request	-
○ 450	5,0/4,0	Auf Anfrage/On request	Auf Anfrage/On request	Auf Anfrage/On request	-
○ 560	3,8/2,8	Auf Anfrage/On request	Auf Anfrage/On request	Auf Anfrage/On request	-
○ 570	5,5/4,0	Auf Anfrage/On request	Auf Anfrage/On request	Auf Anfrage/On request	-
○ 630	6,5/5,0	Auf Anfrage/On request	Auf Anfrage/On request	Auf Anfrage/On request	-
○ 660	6,5/5,0	Auf Anfrage/On request	Auf Anfrage/On request	Auf Anfrage/On request	-
○ 710	6,5/5,5	Auf Anfrage/On request	Auf Anfrage/On request	Auf Anfrage/On request	-
○ 760	6,5/5,0	Auf Anfrage/On request	Auf Anfrage/On request	Auf Anfrage/On request	-
○ 800	6,5/5,0	Auf Anfrage/On request	Auf Anfrage/On request	Auf Anfrage/On request	-
○ 830	6,5/5,0	Auf Anfrage/On request	Auf Anfrage/On request	Auf Anfrage/On request	-
○ 860	8,0/6,0	Auf Anfrage/On request	Auf Anfrage/On request	Auf Anfrage/On request	-
○ 910	8,0/6,0	Auf Anfrage/On request	Auf Anfrage/On request	Auf Anfrage/On request	-
○ 940	8,0/6,0	Auf Anfrage/On request	Auf Anfrage/On request	Auf Anfrage/On request	-
○ 960	8,0/6,0	Auf Anfrage/On request	Auf Anfrage/On request	Auf Anfrage/On request	-
○ 1000	6,0/5,0	Auf Anfrage/On request	Auf Anfrage/On request	Auf Anfrage/On request	-
○ 1000	8,0/6,0	Auf Anfrage/On request	Auf Anfrage/On request	Auf Anfrage/On request	-
○ 1020	6,5/5,0	Auf Anfrage/On request	Auf Anfrage/On request	Auf Anfrage/On request	-
○ 1020	8,0/6,0	Auf Anfrage/On request	Auf Anfrage/On request	Auf Anfrage/On request	-
○ 1040	6,0/5,0	Auf Anfrage/On request	Auf Anfrage/On request	Auf Anfrage/On request	-
○ 1040	8,0/6,0	Auf Anfrage/On request	Auf Anfrage/On request	Auf Anfrage/On request	-
○ 1050	8,5/6,5	Auf Anfrage/On request	Auf Anfrage/On request	Auf Anfrage/On request	-
○ 1060	6,0/5,0	Auf Anfrage/On request	Auf Anfrage/On request	Auf Anfrage/On request	-
○ 1060	8,0/6,0	Auf Anfrage/On request	Auf Anfrage/On request	Auf Anfrage/On request	-
○ 1120	8,0/6,0	Auf Anfrage/On request	Auf Anfrage/On request	Auf Anfrage/On request	-
○ 1125	8,0/6,0	Auf Anfrage/On request	Auf Anfrage/On request	Auf Anfrage/On request	-
○ 1150	6,5/5,0	Auf Anfrage/On request	Auf Anfrage/On request	Auf Anfrage/On request	-
○ 1150	8,0/6,0	Auf Anfrage/On request	Auf Anfrage/On request	Auf Anfrage/On request	-
○ 1160	6,5/5,5	Auf Anfrage/On request	Auf Anfrage/On request	Auf Anfrage/On request	-
○ 1160	8,5/6,5	Auf Anfrage/On request	Auf Anfrage/On request	Auf Anfrage/On request	-
○ 1250	8,0/6,0	Auf Anfrage/On request	Auf Anfrage/On request	Auf Anfrage/On request	-
○ 1320	9,0/7,5	Auf Anfrage/On request	Auf Anfrage/On request	Auf Anfrage/On request	-
○ 1350	9,0/7,5	Auf Anfrage/On request	Auf Anfrage/On request	Auf Anfrage/On request	-
○ 1370	8,2/8,6	Auf Anfrage/On request	Auf Anfrage/On request	Auf Anfrage/On request	-
○ 1430	9,0/7,0	Auf Anfrage/On request	Auf Anfrage/On request	Auf Anfrage/On request	-
○ 1470	9,0/7,0	Auf Anfrage/On request	Auf Anfrage/On request	Auf Anfrage/On request	-
○ 1600	11,0/9,0	Auf Anfrage/On request	Auf Anfrage/On request	Auf Anfrage/On request	-
○ 1700	12,5/10,5	Auf Anfrage/On request	Auf Anfrage/On request	Auf Anfrage/On request	-

Weitere Abmessungen auf Anfrage · Other dimensions are available on request

1



2



3



4



5



6



7



8



9



10



Art.
100
101
102

Baustahl · Edelstahl · Dünobleche · Sandwichmaterial

Mild steel · Stainless steel · Thin iron sheets, Sandwich material

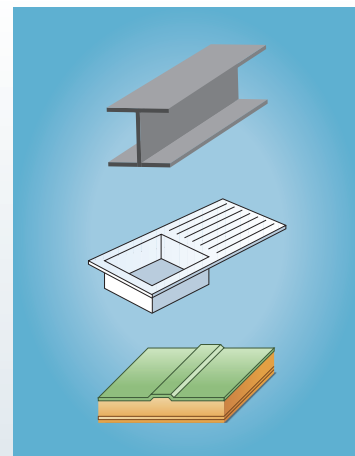

Für Handkreissägen, Tauchsägen, Kapp- und Gehrungssägen, Radialarmsägen, Tisch- und Formatkreissägen, akku-betriebene Maschinen und passend ebenfalls für sogenannte DRY-CUTTER Maschinen mit reduzierten Drehzahlen wie zum Beispiel: JEPSON, RIDGID, ELU, RYOBI...

For portable machines, cross-cut saws, panel and sizing saws, mitre saws, table and radial arms saws, battery-driven saws and suitable also for so-called DRY CUTTER machines with reduced speeds such as: Jepson, RIDGID, ELU, RYOBI...

Schnittwertempfehlungen · Recommended cutting values

Werkstoffgruppe Material Group	Werkstoffbeispiele Material examples	Vc (m/min) Schnittgeschwindigkeit Cutting speed	m/min Handvorschub Manual feed
Baustähle Structural steels	St 37/42 (1.0037 / 1.0042) St 52/60 (1.0050 / 1.0060)	20-35	2-7
Rost- und Säurebeständige Stähle Stainless steel	X 20Cr 13 (14021) X 5CrNi 1810 (14301)	15-30	1.5-4

Drehzahl n (U/min) · Revolution per minute n (rpm)

	1000	1500	2000	2500	2850	3000	4000	4500	5000	5600	6000	8000	9000	10000	12000
80 Ø	4,5	6,5	8,5	10,5	12	13	17	19	21	23,5	26	34	38	42	52
90 Ø	5	7	9,5	12	13,5	14	19	21	24	26,5	28	38	42	48	56
100 Ø	5,5	8	10,5	13	15	16	21	24	26	29	32	42	48	52	54
120 Ø	6,5	9,5	13	16	18	19	26	28	32	35	38	52	56	64	76
125 Ø	7	10	13,5	16,5	18,5	19,5	27	29	33	36,5	39	54	59	66	78
140 Ø	8	11	15	18	21	22	30	33	36	41	44	60	66	72	88
150 Ø	8,5	12	15,5	19,5	22,5	23,5	31,5	33,5	39	44	47	63	70,5	78,5	94,5
160 Ø	9	13	17	21	24	26	34	38	42	47	52	68	76	84	104
180 Ø	10	14	19	24	27	28	38	42,5	48	53	56	76	85	96	118
200 Ø	11	16	21	26	30	32	42	47	52	58,5	64	84	94	104	128
225 Ø	12	18	24	30	33,5	36	48	58	60	66	72	96	106	120	144
250 Ø	14	20	26	33	37	40	52	59	66	73,5	80	104	118	132	160
300 Ø	17	24	31,5	40	45	48	63	71	80	88	96	126	142	160	192
350 Ø	19	28	36,5	47	52	56	73	88	94	105	112	146	166	188	224
400 Ø	22	32	42	54	60	64	84	94	108	117	128	168	188	216	256
450 Ø	24	35,5	47	59	67,5	70,5	94,5	106	118	132	141,6	188	211	236	283
500 Ø	27	40	53	67	74,5	80	106	118	134	146,5	160	212	236	268	320

Schnittgeschwindigkeit in m/s · Cutting speed in m/s

1 Stahl, Edelstahl
Steel, stainless steel

2 Sicherheitsgrenze
Safety limits

Festlegung der Schnittgeschwindigkeit Vc
Determination of cutting speed Vc

BEMERKUNG · COMMENT

Die Kreissägen in dieser Rubrik sind nicht für die Serienfertigung von Stahlabschnitten konzipiert. Diese Sägen sind ideal um schnell nahezu alle Materialien zu sägen wie: Stahl, Nichteisenmetalle, Kunststoffe, Sandwich und Verbundmaterial. Also Ideal als Baustellensäge sowie für den Laden- und Messebauer. Um Stahl in Serie/Produktion zu sägen empfehlen wir Kreissägen siehe Seiten 532-535

The Circular Saws in this Category are not designed for the mass production of steel sections. These saws are ideal for fast cuts in almost any material such as: Steel, non-ferrous metals, plastics, composites and sandwich material. The perfect saws for the building site as well as for store and stand builders. If steel is to be cut in series / production, we recommend our circular saws see page 532-535



Baustahl · Edelstahl · Dünobleche · Sandwichmaterial

Mild steel · Stainless steel · Thin iron sheets,
Sandwich material

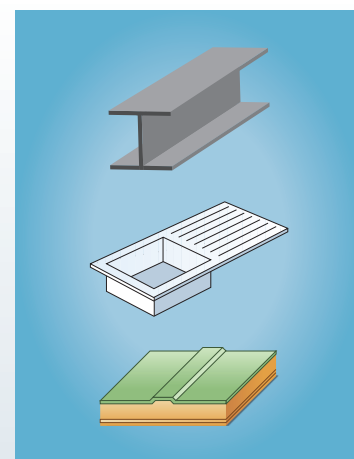

Art. Ø mm	Type	Anwendung · Application	
10.7100 Ø mm 136-500 	Dry-Cutter Baustähle	Schwerpunkt ist das Trennen von Profilmaterial sowie Bleche bis ca. 6 mm Wandstärke	538
	Dry-Cutter mild steel	The focus is on cutting profile material and sheet metals up to 6 mm wall thickness	
10.7200 Ø mm 250-355 	Super Dry-Cutter Baustähle	Schwerpunkt ist das Trennen von Profilmaterial sowie Bleche bis ca. 8 mm Wandstärke	539
	Super Dry-Cutter mild steel	The focus is on cutting profile material and sheet metals up to 8 mm wall thickness	
10.7300 Ø mm 136-500 	Dry-Cutter Edelstahl	Schwerpunkt ist das Trennen von Profilmaterial sowie Bleche aus Edelstahl bis ca. 4 mm Wandstärke	540
	Dry-Cutter stainless	The focus is cutting of profile material and sheets of stainless steel up to no more than 4mm wall thickness	
10.7400 Ø mm 136-500 	Dry-Cutter Sandwich	Schwerpunkt ist das Trennen von Dünoblech bis ca. 3 mm sowie Sandwichmaterialien, Fassadenprofile u.ä.	541
	Dry-Cutter sandwich	The focus is on cutting thin sheet up to approx. 3mm and sandwich materials, façade profiles, etc.	
10.8055 Ø mm 120-500 	Winkelschleifer + Brutal Einweg-Sägeblätter	Brutal Einweg-Sägeblätter zum Sägen „fast“ aller Materialien. Ideal für Bau und Handwerk	543
	Angle Grinder + Brutal disposable saw blades	Brutal disposable saw blades for sawing "almost" any material. Ideal for construction and crafts	

1



2



3



4



5



6



7



8



9



10



Art.
100
101
102

Art. **10.7100**

Dry-Cutter Baustähle
Dry-Cutter mild steel

GOLD-STAR LINE

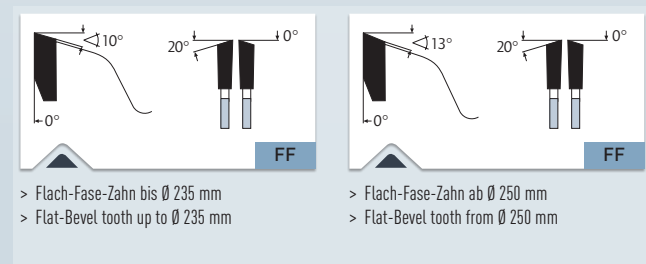

> Flach-Fase-Zahn bis Ø 235 mm
> Flat-Bevel tooth up to Ø 235 mm

> Flach-Fase-Zahn ab Ø 250 mm
> Flat-Bevel tooth from Ø 250 mm

MASCHINE · MACHINE

Für Handkreissägen, Tauchsägen, Kapp- und Gehrungssägen, Radialarmsägen, Tisch- und Formatkreissägen, akkubetriebene Maschinen und passend ebenfalls für sogenannte DRY-CUTTER Maschinen mit reduzierten Drehzahlen wie zum Beispiel: JEPSON, RIDGID, ELU, RYOBI...

For portable machines, cross-cut saws, panel and sizing saws, mitre saws, table and radial arms saws, battery-driven saws and suitable also for so-called DRY CUTTER machines with reduced speeds such as: Jepson, RIDGID, ELU, RYOBI...

Bei Stahl ist es vorteilhaft mit reduzierten Drehzahlen (min⁻¹) zu arbeiten (siehe Tabelle unten). Die Verwendung von Schneidspray oder Mecut-wachs erhöht wesentlich die Standzeit (Schneidöle siehe ab Seite 711).

For steel, it is beneficial to work at reduced speeds (see table below). Use of cutting spray or Mecut wax increases the service life (coolants see from page 711)

Ø 160-200 mm = 3500-3000 min⁻¹/rpm

Ø 210-250 mm = 2800-1900 min⁻¹/rpm

Ø 260-305 mm = 1800-1500 min⁻¹/rpm

Ø 350-400 mm = 1500-1000 min⁻¹/rpm

Trennen von Dünnschleif bis ca. 3 mm Wandstärke sowie Sandwichmaterial siehe Art. 10.7400 Seite 541

Trennen von Edelstahl bis ca. 4 mm siehe Art. 10.7300 Seite 540

Trennen von Aluprofilen/Alublechen siehe Art. 10.8000 Seite 546 / Art. 11.1100 Seite 553 / Art. 11.1120 Seite 555

Trennen von Holz, Kunststoffen, NE-Metallen wie Alu, Baustähle siehe Art. 10.8055 Seite 543

Cutting thin sheet up to approx. 3mm wall thickness and sandwich material: see item 10.7400 page 541

Cutting stainless steel up to approx. 4mm: see item 10.7300 page 540

Cutting of aluminium profiles/sheets: see item 10.8000 page 546 / item 11.1100 page 553 / item 11.1120 page 555

Cutting of wood, plastics, non-ferrous materials like aluminium, mild steels: see item 10.8055 page 543

✓ OPTIMAL · OPTIMAL ✓ GUT · GOOD ✓ MÖGLICH · POSSIBLE

✓		Baustahl	Mild steel
✓		Ne-Metall wie Alu, Messing, Kupfer	Non ferrous materials like alu, copper, brass
✓		Dünnschleif, Sandwich Material, Verbundstoffe	Thin iron sheets, sandwich material, composites
✓		Kunststoffe, Plexiglas, Duro- und Thermoplaste	Plastics, plexiglass, acrylics, duro- and thermoplastics

ANWENDUNG · APPLICATION

Schwerpunkt ist das Trennen von Profilmaterial sowie Bleche bis ca. 6 mm Wandstärke. Die höhere Zähnezahl ist bis ca. 3 mm Wandstärke geeignet. Für noch höhere Standzeiten und zum Trennen bis zu 8 mm Wandstärke siehe unsere neuen **Super Dry-Cutter Baustähle** Blätter. (Art. 10.7200 / Seite 539).

The focus is on cutting profile material and sheet metals up to 6 mm wall thickness. The higher number of teeth is suitable up to 3 mm thickness. For higher service lives and cutting up to 8 mm thickness see our new **Super Dry-Cutter mild steel** sheets. (item.10.7200/ page 539).

Art.							€
107100.136.010	● 136	1,6/1,2	20/10	30 FF	2-6-32	-	32,45
107100.150.010	● 150	1,8/1,4	20/16	30 FF	2-6-32	-	32,75
107100.160.010	● 160	1,8/1,4	20/16	30 FF	2-6-32	-	33,65
107100.180.010	● 180	1,8/1,4	30/20	34 FF	UNI 1	-	37,55
107100.185.010	● 185	1,8/1,4	20/16	34 FF	2-6-32	-	37,55
107100.190.010	● 190	1,8/1,4	30	38 FF	UNI 1	-	38,45
107100.200.010	● 200	2,0/1,6	30	40 FF	UNI 1	-	42,95
107100.210.010	● 210	2,0/1,6	30	40 FF	UNI 1	-	43,55
107100.216.010	● 216	2,0/1,6	30	42 FF	UNI 1	-	46,25
107100.230.010	● 230/235	2,0/1,6	30	44 FF	UNI 1	-	47,15
107100.250.010	● 250	2,2/1,8	30/25,4	48 FF	UNI 1 + UNI 2	✓	59,15
107100.250.020	● 250	2,2/1,8	30/25,4	60 FF	UNI 1 + UNI 2	✓	75,65
107100.260.010	● 260	2,2/1,8	30	60 FF	UNI 1 + UNI 2	✓	81,35
107100.270.010	● 270	2,2/1,8	30	60 FF	UNI 1 + UNI 2	✓	82,85
107100.280.010	● 280	2,2/1,8	30	60 FF	UNI 1 + UNI 2	✓	84,35
107100.300.010	● 300	2,2/1,8	30	60 FF	UNI 1 + UNI 2	✓	85,55
107100.300.020	● 300	2,2/1,8	30	80 FF	UNI 1 + UNI 2	✓	104,15
107100.305.010	● 305	2,2/1,8	25,4	60 FF	-	✓	83,15
107100.305.020	● 305	2,2/1,8	25,4	80 FF	-	✓	104,15
107100.320.010	● 320	2,2/1,8	30/25,4	84 FF	UNI 1 + UNI 2	✓	107,15
107100.330.010	● 330	2,2/1,8	32/30	84 FF	UNI 2	✓	108,35
107100.350.010	● 350	2,2/1,8	30	80 FF	UNI 1 + UNI 2	✓	108,35
107100.355.010	● 355	2,2/1,8	25,4	60 FF	-	✓	94,55
107100.355.020	● 355	2,2/1,8	25,4	80 FF	-	✓	108,35
107100.355.030	● 355	2,2/1,8	25,4	90 FF	1-12-55,4	✓	115,55
107100.400.010	● 400	2,6/3,0	30	84 FF	UNI 1 + UNI 2	✓	138,35
107100.420.010	● 420	2,6/3,0	30	84 FF	UNI 1 + UNI 2	✓	153,95
107100.450.010	● 450	2,8/2,4	30	90 FF	UNI 1 + UNI 2	✓	169,25
107100.500.010	● 500	3,0/2,6	30	100 FF	UNI 1 + UNI 2	✓	201,05

UNI 1 = 2-7-42 + 2-9-46,4 UNI 2 = 2-10-60 + 2-11-63 + 2-12-64 · ● Gefertigt/Manufactured 232,50 mm



Super Dry-Cutter Baustähle
Super Dry-Cutter mild steel

Art. 10.7200

GOLD-STAR LINE

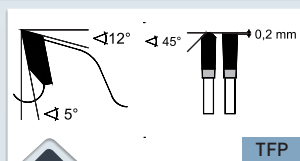

TFP

- > Trapez Flach Positiv
- > Triple-chip / flat tooth positive

MASCHINE - MACHINE

Für Handkreissägen, Tauchsägen, Kapp- und Gehrungssägen, Radialarmsägen, Tisch- und Formatkreissägen, akkubetriebene Maschinen und passend ebenfalls für sogenannte DRY-CUTTER Maschinen mit reduzierten Drehzahlen wie zum Beispiel: JEPSON, RIDGID, ELU, RYOBI...

For portable machines, cross-cut saws, panel and sizing saws, mitre saws, table and radial arms saws, battery-driven saws and suitable also for so-called DRY CUTTER machines with reduced speeds such as: JEPSON, RIDGID, ELU, RYOBI...

Bei Stahl ist es vorteilhaft mit reduzierten Drehzahlen (min^{-1}) zu arbeiten (siehe Tabelle unten). Die Verwendung von Schneidspray oder Mecutwachs erhöht wesentlich die Standzeit (Schneidöle siehe ab Seite 711).

For steel, it is beneficial to work at reduced speeds (see table below). Use of cutting spray or Mecut wax increases the service life (coolants see from page 711)

Ø 160-200 mm = 3500-3000 min^{-1} /rpm

Ø 210-250 mm = 2800-1900 min^{-1} /rpm

Ø 260-305 mm = 1800-1500 min^{-1} /rpm

Ø 350-400 mm = 1500-1000 min^{-1} /rpm

Weitere Abmessungen siehe Art. 10.7100 Seite 538

Trennen von Dünnschicht bis ca. 3 mm Wandstärke sowie Sandwichmaterial siehe Art. 10.7400 Seite 541

Trennen von Edelstahl bis ca. 4 mm siehe Art. 10.7300 Seite 540

Trennen von Aluprofilen/ Alublechen siehe Art. 10.8000 Seite 546 / Art. 11.1100 Seite 553 / Art. 11.1120 Seite 555

Trennen von Holz, Kunststoffen, NE-Metallen wie Alu, Baustähle siehe Art. 10.8055 Seite 543

For other sizes, see item 10.7100 page 538

Cutting thin sheet up to approx. 3mm wall thickness and sandwich material: see item 10.7400 page 541

Cutting stainless steel up to approx. 4mm: see item 10.7300 page 540

Cutting of aluminium profiles/sheets: see item 10.8000 page 546 / item 11.1100 page 553 / item 11.1120 page 555

Cutting of wood, plastics, non-ferrous materials like aluminium, mild steels: see item 10.8055 page 543

- ✓ OPTIMAL · OPTIMAL
- ✓ GUT · GOOD
- ✓ MÖGLICH · POSSIBLE

✓		Baustahl	Mild steel
✓		Ne-Metall wie Alu, Messing, Kupfer	Non ferrous materials like alu, copper, brass
✓		Dünnschicht, Sandwich Material, Verbundstoffe	Thin iron sheets, sandwich material, composites
✓		Kunststoffe, Plexiglas, Duro- und Thermoplaste	Plastics, plexiglass, acrylics, duro- and thermoplastics

ANWENDUNG - APPLICATION

Schwerpunkt ist das Trennen von Profilmaterial sowie Bleche bis ca. 8 mm Wandstärke. Durch spezielles Hartmetall, Geometrie sowie Stammblatt wird die Standzeit gegenüber unseren **Dry-Cutter Baustähle** Blättern (Art. 10.7100, Seite 538) in den Ø 250-355 mm nochmals wesentlich erhöht. Als Universalblatt auch einsetzbar für Sandwich-Materialien.

The focus is on cutting profile material and sheets up to no more than approx. 8 mm wall thickness. Special carbide, geometry and saw body increases the service life as compared to our **Dry-Cutter mild steel** sheets (item 10.7100, page 538) essentially again in the 250-355 mm range. Can be used as Universal blade. Also suitable for sandwich materials.

Art.							€
107200.250.010	▲ 250	2,2/1,8	30	48 TFP	UNI 1 + UNI 2	✓	68,75
107200.255.010	▲ 255	2,2/1,8	25,4	48 TFP	-	✓	68,05
107200.300.010	▲ 300	2,2/1,8	30	60 TFP	UNI 1 + UNI 2	✓	91,70
107200.305.010	▲ 305	2,2/1,8	25,4	60 TFP	-	✓	90,95
107200.350.010	▲ 350	2,4/2,0	30	72 TFP	UNI 1 + UNI 2	✓	114,60
107200.355.010	▲ 355	2,4/2,0	25,4	72 TFP	-	✓	114,05

UNI 1 = 2-7-42 + 2-9-46,4 UNI 2 = 2-10-60 + 2-11-63 + 2-12-64

- ▲ Solange Vorrat reicht.
- ▲ While stocks last.



Video



539

- 1
- 2
- 3
- 4
- 5
- 6
- 7
- 8
- 9
- 10

Art. 100 101 102

Karnasch® HARTMETALL-BESTÜCKTE KREISSÄGEBLÄTTER CARBIDE TIPPED CIRCULAR SAW BLADES

Art. **10.7300**

Dry-Cutter Edelstahl
Dry-Cutter stainless

GOLD-STAR LINE



✓ OPTIMAL · OPTIMAL ✓ GUT · GOOD ✓ MÖGLICH · POSSIBLE

✓		Edelstahl	Stainless steel
---	--	-----------	-----------------

ANWENDUNG · APPLICATION

Schwerpunkt ist das Sägen von Profilen und Blechen aus Edelstahl mit einer Zugfestigkeit von bis zu 700 N/mm² und Wandstärken bis ca. 4 mm

Focus is the sawing of profiles and sheets in stainless steel with a tensile strength up to 700 N/mm² and wall thickness up to 4mm

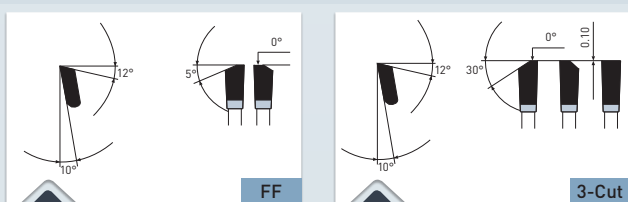

> Flach-Fase-Zahn
> Flat-Bevel tooth

> 3-Cut
> 3-Cut

MASCHINE · MACHINE

Für Handkreissägen, Tauchsägen, Kapp- und Gehrungssägen, Radialarmsägen, Tisch- und Formatkreissägen, akkubetriebene Maschinen und passend ebenfalls für sogenannte DRY-CUTTER Maschinen mit reduzierten Drehzahlen wie zum Beispiel: JEPSON, RIDGID, ELU, RYOBI...

For portable machines, cross-cut saws, panel and sizing saws, mitre saws, table and radial arms saws, battery-driven saws and suitable also for so-called DRY CUTTER machines with reduced speeds such as: JEPSON, RIDGID, ELU, RYOBI...

Ø 160-200 mm = 3500-3000 min⁻¹/rpm

Ø 210-250 mm = 2800-1900 min⁻¹/rpm

Ø 260-305 mm = 1800-1500 min⁻¹/rpm

Ø 350-400 mm = 1500-1000 min⁻¹/rpm

Bei Stahl ist es vorteilhaft mit reduzierten Drehzahlen (min⁻¹) zu arbeiten (siehe Tabelle oben). Die Verwendung von Schneidspray oder Mecutwax erhöht wesentlich die Standzeit (Schneidöle siehe ab Seite 711).

For steel, it is beneficial to work at reduced speeds (see table above). Use of cutting spray or Mecut wax increases the service life (coolants see from page 711)

Art.							€
107300.136.010	● 136	1,6/1,20	20/10	36 FF	2-6-32	-	34,55
107300.160.010	● 160	1,8/1,40	20/16	40 FF	2-6-32	-	39,05
107300.180.010	● 180	1,8/1,40	30/20	44 FF	UNI 1	-	42,05
107300.185.010	● 185	1,8/1,40	20/16	44 FF	2-6-32	-	42,05
107300.190.010	● 190	1,8/1,40	30/20	48 FF	UNI 1	-	45,05
107300.200.010	● 200	2,0/1,6	30	48 FF	UNI 1	-	46,55
107300.210.010	● 210	2,0/1,6	30	54 FF	UNI 1	-	60,05
107300.216.010	● 216	2,0/1,6	30	54 FF	UNI 1	-	60,05
107300.230.010	● 230/235	2,0/1,6	30	56 FF	UNI 1	-	64,55
107300.250.010	● 250	2,2/1,8	30	60 / 3-Cut	UNI 1 + UNI 2	✓	79,55
107300.255.010	● 255	2,2/1,8	25,4	60 / 3-Cut	-	✓	79,55
107300.260.010	● 260	2,2/1,8	30	72 / 3-Cut	UNI 1 + UNI 2	✓	100,55
107300.270.005	▲ 270	2,2/1,8	30	68 TF	UNI 1 + UNI 2	✓	92,40
107300.270.010	● 270	2,2/1,8	30	72 / 3-Cut	UNI 1 + UNI 2	✓	102,05
107300.300.010	● 300	2,2/1,8	30	72 / 3-Cut	UNI 1 + UNI 2	✓	106,55
107300.305.010	● 305	2,2/1,8	25,4	72 / 3-Cut	-	✓	106,55
107300.320.010	● 320	2,2/1,8	30/25,4	84 / 3-Cut	UNI 1 + UNI 2	✓	112,55
107300.330.010	● 330	2,2/1,8	32/30	84 / 3-Cut	UNI 2	✓	114,05
107300.350.010	● 350	2,2/1,8	30	84 / 3-Cut	UNI 1 + UNI 2	✓	118,55
107300.355.010	● 355	2,2/1,8	25,4	84 / 3-Cut	-	✓	118,55
107300.400.010	● 400	2,6/2,2	30	90 / 3-Cut	UNI 1 + UNI 2	✓	154,55
107300.420.010	● 420	2,6/2,2	30	96 / 3-Cut	UNI 1 + UNI 2	✓	174,05
107300.450.010	● 450	2,8/2,4	30	108 / 3-Cut	UNI 1 + UNI 2	✓	193,55
107300.500.010	● 500	3,0/2,6	30	120 / 3-Cut	UNI 1 + UNI 2	✓	259,55

UNI 1 = 2-7-42 + 2-9-46,4 UNI 2 = 2-10-60 + 2-11-63 + 2-12-64 · ● Gefertigt/Manufactured 232,50 mm



Video

Dry-Cutter Sandwich
Dry-Cutter sandwich

Art. 10.7400

GOLD-STAR LINE

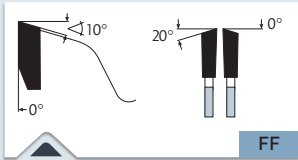

> Flach-Fase-Zahn bis Ø 235 mm
> Flat-Bevel tooth up to Ø 235 mm

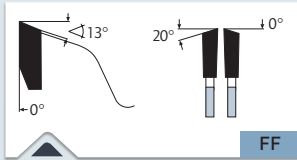

> Flach-Fase-Zahn ab Ø 250 mm
> Flat-Bevel tooth from Ø 250 mm

MASCHINE · MACHINE

Für Handkreissägen, Tauchsägen, Kapp- und Gehrungssägen, Radial-armsägen, Tisch- und Formatkreissägen, akkubetriebene Maschinen und passend ebenfalls für sogenannte DRY-CUTTER Maschinen mit reduzierten Drehzahlen wie zum Beispiel: JEPSON, RIDGID, ELU, RYOBI...

For portable machines, cross-cut saws, panel and sizing saws, mitre saws, table and radial arms saws, battery-driven saws and suitable also for so-called DRY CUTTER machines with reduced speeds such as: JEPSON, RIDGID, ELU, RYOBI...

✓ OPTIMAL · OPTIMAL ✓ GUT · GOOD ✓ MÖGLICH · POSSIBLE

✓		Dünnscheibe, Sandwich Material, Verbundstoffe	Thin iron sheets, sandwich material, composites
✓		Baustahl	Mild steel
✓		Ne-Metall wie Alu, Messing, Kupfer	Non ferrous materials like alu, copper, brass
✓		Kunststoffe, Plexiglas, Duro- und Thermoplaste	Plastics, plexiglass, acrylics, duro- and thermoplastics

ANWENDUNG · APPLICATION

Schwerpunkt ist das Trennen von dünnwandigen Blechen/Profilen aus Baustahl bis zu 3 mm Wandstärke. Hervorragend für Sandwichmaterialien mit dünnen Deckschichten aus Stahl/Alu/Kunststoffen von ca. 0,2-1 mm. Weiterhin gut geeignet zum Trennen von Blechen/Profilen aus Ne-Metallen (Alu, Kupfer, Messing) und Kunststoffen bis ca. 5 mm Wandstärke.

Focus is on the cutting thin-walled sheet metal/steel profiles up to 3mm wall thickness. Great for sandwich materials with thin layers of steel/aluminium/plastics of about 0.2-1mm. Also highly suitable for cutting sheets/profiles from non-ferrous metals (Aluminium, copper, brass) and plastics up to 5mm wall thickness.

Art.								€
107400.136.010	● 136	1,6/2,0	20/10	38 FF	2-6-32	-	-	33,35
107400.160.010	● 160	1,8/1,4	20/16	42 FF	2-6-32	-	-	37,85
107400.180.010	● 180	1,8/1,4	30/20	48 FF	UNI 1	-	-	41,45
107400.185.010	● 185	1,8/1,4	20/16	48 FF	2-6-32	-	-	41,45
107400.190.010	● 190	1,8/1,4	30	48 FF	UNI 1	-	-	42,95
107400.200.010	● 200	2,0/1,6	30	54 FF	UNI 1	-	-	57,05
107400.210.010	● 210	2,0/1,6	30	54 FF	UNI 1	-	-	57,05
107400.216.010	● 216	2,0/1,6	30	54 FF	UNI 1	-	-	57,05
107400.230.010	● 230/235	2,0/1,6	30	54 FF	UNI 1	-	-	60,95
107400.250.010	● 250	2,2/1,8	30	72 FF	UNI 1 + UNI 2	✓	✓	82,55
107400.255.010	● 255	2,2/1,8	25,4	72 FF	-	✓	✓	85,85
107400.260.010	● 260	2,2/1,8	30	72 FF	UNI 1 + UNI 2	✓	✓	86,75
107400.270.010	● 270	2,2/1,8	30	72 FF	UNI 1 + UNI 2	✓	✓	87,05
107400.300.010	● 300	2,2/1,8	30	84 FF	UNI 1 + UNI 2	✓	✓	97,85
107400.305.010	● 305	2,2/1,8	25,4	84 FF	-	✓	✓	97,85
107400.320.010	● 320	2,2/1,8	30/25,4	96 FF	UNI 1 + UNI 2	✓	✓	119,75
107400.330.010	● 330	2,2/1,8	32/30	96 FF	UNI 2	✓	✓	121,55
107400.350.010	● 350	2,2/1,8	30	100 FF	UNI 1 + UNI 2	✓	✓	122,15
107400.355.010	● 355	2,2/1,8	25,4	100 FF	-	✓	✓	122,15
107400.400.010	● 400	2,6/2,0	30	110 FF	UNI 1 + UNI 2	✓	✓	180,95
107400.420.010	● 420	2,6/2,0	30	110 FF	UNI 1 + UNI 2	✓	✓	189,95
107400.450.010	● 450	2,8/2,4	30	120 FF	UNI 1 + UNI 2	✓	✓	222,65
107400.500.010	● 500	3,0/2,6	30	130 FF	UNI 1 + UNI 2	✓	✓	270,05

UNI 1 = 2-7-42 + 2-9-46,4 UNI 2 = 2-10-60 + 2-11-63 + 2-12-64 • Gefertigt/Manufactured 232,50 mm



Video

541



10
Art.
100
101
102

Karnasch® HARTMETALL-BESTÜCKTE KREISSÄGEBLÄTTER CARBIDE TIPPED CIRCULAR SAW BLADES

Art. **10.8055**

Winkelschleifer + Brutal Einweg-Sägeblätter
Angle Grinder + Brutal disposable saw blades

GOLD-STAR LINE



✓ OPTIMAL · OPTIMAL ✓ GUT · GOOD ✓ MÖGLICH · POSSIBLE

✓		Baustahl	Mild steel
✓		Ne-Metall wie Alu, Messing, Kupfer	Non ferrous materials like alu, copper, brass
✓		Dünobleche, Sandwich Material, Verbundstoffe	Thin iron sheets, sandwich material, composites
✓		Kunststoffe, Plexiglas, Duro- und Thermoplaste	Plastics, plexiglass, acrylics, duro- and thermoplastics
✓		Weichholz, Hartholz, Exotenholz, Quer	Soft wood, hard wood, and exotic wood across the grain
✓		Holz mit Einschlüssen wie Nägel, Klammern, Beton- und Mörtelreste	Wood with inclusions like nails, clips, concrete residues
✓		Weichholz, Hartholz, Exotenholz Längs	Soft wood, hard wood, and exotic wood along the grain
✓		Leimholz, Tischler- und Furniersperrholz, Schichtholzplatten	Bonded wood, blockboard and veneer plywood, laminated wood
✓		Spanplatten, Hartfaserplatten, Platten ohne Belag LDF, MDF, HDF	Chipboard, hard fibre board, boards without laminate LDF, MDF, HDF
✓		Spanplatten, Hartfaserplatten Kunststoff beschichtet/furniert, MDF, HDF	Chipboard, hard fibre board, plastic-coated/veneered, MDF, HDF
✓		HPL-Duroplastische Schichtstoffplatten/Fassadenplatten: Trespa®, Resopal®, Duropal®, Formica®, Kronospan®, Decodur®	HPL High-Pressure-Laminate solid boards/façade panels: Trespa®, Resopal®, Duropal®, Formica®, Kronospan®, Decodur®
✓		Furniere	Veneers
✓		Profileleisten	Profiled wood
✓		Gasbetonsteine	Autoclaved aerated concrete blocks
✓		Mineralische/acrylgebundene Massivplatten/Küchenplatten: Corian®, Noblan®, Hi-Macs®, Staron®, Rausolid®, Varicor®	Mineral/acrylic bound solid boards/kitchen worktops: Corian®, Noblan®, Hi-Macs®, Staron®, Rausolid®, Varicor®
✓		Gips-Zement-Steinwollplatten, Eternit, GFK, CFK, HPL, Mineralwerkstoffe	Gypsum/Cement fibre boards, Rockwool, Eternit, GRP, CFK, HPL, Mineral material

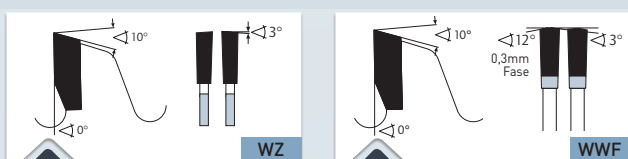

> Wechselzahn
> Alternate top bevel

> Wechselzahn-Fase
> Alternate top bevel+bevel

MASCHINE · MACHINE

Für Handkreissägen, Tauchsägen, Kapp- und Gehrungssägen, Radialarmsägen, Tisch- und Formatkreissägen, akkubetriebene Maschinen und passend ebenfalls für sogenannte DRY-CUTTER Maschinen mit reduzierten Drehzahlen wie zum Beispiel: JEPSON, RIDGID, ELU, RYOBI...

For portable machines, cross-cut saws, panel and sizing saws, mitre saws, table and radial arms saws, battery-driven saws and suitable also for so-called DRY CUTTER machines with reduced speeds such as: JEPSON, RIDGID, ELU, RYOBI...

Ø 160-200 mm = 3500-3000 min⁻¹ /rpm

Ø 210-250 mm = 2800-1900 min⁻¹ /rpm

Ø 260-305 mm = 1800-1500 min⁻¹ /rpm

Ø 350-400 mm = 1500-1000 min⁻¹ /rpm

Bei Stahl ist es vorteilhaft mit reduzierten Drehzahlen (min⁻¹) zu arbeiten (siehe Tabelle oben). Die Verwendung von Schneidspray oder Mecutwachs erhöht wesentlich die Standzeit (Schneidöle siehe ab Seite 711).

For steel, it is beneficial to work at reduced speeds (see table above). Use of cutting spray or Mecut wax increases the service life (for cutting oils, see from page 711)

Art. **10.8056** € **38,00**



Blätter 120 mm passen für Winkelschleifer 115 + 125 mm.

Blade diameter 120 mm suitable for angle grinder diameter 115-125 mm.

Verwendung in Europa nur erlaubt mit Schutzhaube (wird komplett mit Spindelmutter, Stirnlochschlüssel, Absaugstutzen und Bedienungsanleitung geliefert).

Use in europe only permitted with protection cover (delivered completely with spindle nut, open-faced spanner, exhaust socket and operating instructions).



ANWENDUNG · APPLICATION

Brutal Einweg-Sägeblätter zum Sägen „fast“ aller Materialien. Ideal für Bau und Handwerk. Durch geringe Schnittbreite wenig Schnittverlust sowie Schnittwiderstand. Daher auch ideal für Akku-Maschinen.

Niedrigste Zähnezahl: Zum schnellen Trennen aller Arten von Hölzern (auch mit Nägeln, Klammern), Kunststoffen, NE-Metallen. Grober Schnitt.

Mittlere Zähnezahl: Zum Trennen aller angegebenen Materialien. Mittlere Schnittgüte (Zum Trennen von Baustählen, NE-Metalle empfehlen wir die höchste Zähnezahl).

Höchste Zähnezahl: Zum Trennen aller angegebenen Materialien. Vorzugsweise für alle Metalle, wie Baustähle, Alu und andere NE-Metalle.

Brutal disposable saw blades for sawing "almost" any material. Ideal for construction and crafts. The low cutting width leads to little cutting wastage and cutting resistance. Therefore also ideal for battery-powered machines.

Lowest tooth number: For fast cutting of all kinds of woods (also with nails, clamps, plastics, non-ferrous materials). Coarse cut.

Medium tooth number: For cutting of all specified materials. Medium cutting quality (for cutting of mild steels, non-ferrous metals, we recommend the highest number of teeth).

Highest tooth number: For cutting of all specified materials. Preferably for all metals like mild steels, aluminium and other non-ferrous metals.







Video

Winkelschleifer + Brutal Einweg-Sägeblätter
Angle Grinder + Brutal disposable saw blades

Art. **10.8055**

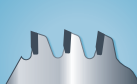

Art.						€
108055.120.010	● *120	2,0/1,4	25,4/22	14 WZ	-	16,05
108055.120.020	● *120	2,0/1,4	25,4/22	24 WZ	-	23,70
108055.120.030	● *120	2,0/1,4	25,4/22	40 WWF	-	35,88
108055.136.010	● 136	2,0/1,4	20/10	16 WZ	-	18,35
108055.136.020	● 136	2,0/1,4	20/10	30 WZ	-	28,95
108055.136.030	● 136	2,0/1,4	20/10	40 WWF	-	36,55
108055.160.010	● 160	2,0/1,4	20/16	18 WZ	2-6-32	20,50
108055.160.020	● 160	2,0/1,4	20/16	30 WZ	2-6-32	29,70
108055.160.030	● 160	2,0/1,4	20/16	40 WWF	2-6-32	37,50
108055.165.010	● 165	2,0/1,4	20	18 WZ	2-6-32	21,10
108055.165.020	● 165	2,0/1,4	20	30 WZ	2-6-32	30,30
108055.165.030	● 165	2,0/1,4	20	40 WWF	2-6-32	38,25
108055.180.005	▲ 180	2,2/1,6	22,22	10 WZ	-	23,95
108055.180.010	● 180	2,0/1,4	30/22/20	20 WZ	UNI 1	24,60
108055.180.020	● 180	2,0/1,4	30/22/20	34 WZ	UNI 1	32,30
108055.180.030	● 180	2,0/1,4	30/22/20	48 WWF	UNI 1	45,95
108055.185.010	● 185	2,0/1,4	20/16	20 WZ	2-6-32	23,45
108055.185.020	● 185	2,0/1,4	20/16	34 WZ	2-6-32	34,10
108055.185.030	● 185	2,0/1,4	20/16	48 WWF	2-6-32	44,80
108055.190.010	● 190	2,0/1,4	30	20 WZ	UNI 1	22,70
108055.190.020	● 190	2,0/1,4	30	34 WZ	UNI 1	33,30
108055.190.030	● 190	2,0/1,4	30	48 WWF	UNI 1	44,05
108055.210.010	● 210	2,0/1,4	30	22 WZ	UNI 1	26,00
108055.210.020	● 210	2,0/1,4	30	36 WZ	UNI 1	36,85
108055.210.030	● 210	2,0/1,4	30	48 WWF	UNI 1	46,25
108055.216.010	● 216	2,0/1,4	30	24 WZ	UNI 1	28,35
108055.216.020	● 216	2,0/1,4	30	36 WZ	UNI 1	37,85
108055.216.030	● 216	2,0/1,4	30	48 WWF	UNI 1	47,25
108055.225.010	● 225	2,0/1,4	30	24 WZ	UNI 1	28,35
108055.225.020	● 225	2,0/1,4	30	36 WZ	UNI 1	37,85
108055.225.030	● 225	2,0/1,4	30	48 WWF	UNI 1	47,25
108055.230.010	● 230/235 ●	2,0/1,4	30/22	24 WZ	UNI 1	29,90
108055.230.020	● 230/235 ●	2,0/1,4	30/22	36 WZ	UNI 1	39,05
108055.230.030	● 230/235 ●	2,0/1,4	30/22	48 WWF	UNI 1	48,20
108055.250.010	● 250	2,4/1,8	30/25,4	28 WZ	UNI 1 + UNI 2	37,35
108055.250.020	● 250	2,4/1,8	30/25,4	44 WZ	UNI 1 + UNI 2	49,60
108055.250.030	● 250	2,4/1,8	30/25,4	60 WWF	UNI 1 + UNI 2	61,75
108055.260.010	● 260	2,4/1,8	30	28 WZ	UNI 1 + UNI 2	37,35
108055.260.020	● 260	2,4/1,8	30	44 WZ	UNI 1 + UNI 2	49,60
108055.260.030	● 260	2,4/1,8	30	60 WWF	UNI 1 + UNI 2	61,80
108055.270.010	● 270	2,4/1,8	30	30 WZ	UNI 1 + UNI 2	39,75
108055.270.020	● 270	2,4/1,8	30	46 WZ	UNI 1 + UNI 2	51,95
108055.270.030	● 270	2,4/1,8	30	60 WWF	UNI 1 + UNI 2	62,70
108055.280.010	● 280	2,4/1,8	30	32 WZ	UNI 1 + UNI 2	42,35
108055.280.020	● 280	2,4/1,8	30	48 WZ	UNI 1 + UNI 2	54,70
108055.280.030	● 280	2,4/1,8	30	60 WWF	UNI 1 + UNI 2	64,00
108055.300.010	● 300	2,4/1,8	30	32 WZ	UNI 1 + UNI 2	44,95
108055.300.020	● 300	2,4/1,8	30	48 WZ	UNI 1 + UNI 2	57,40
108055.300.030	● 300	2,4/1,8	30	60 WWF	UNI 1 + UNI 2	66,85
108055.305.010	● 305	2,4/1,8	30/25,4	32 WZ	UNI 1 + UNI 2	46,10
108055.305.020	● 305	2,4/1,8	30/25,4	48 WZ	UNI 1 + UNI 2	58,30
108055.305.030	● 305	2,4/1,8	30/25,4	60 WWF	UNI 1 + UNI 2	67,60
108055.320.010	● 320	2,4/1,8	30/25,4	32 WZ	UNI 1 + UNI 2	47,75
108055.320.020	● 320	2,4/1,8	30/25,4	48 WZ	UNI 1 + UNI 2	60,40
108055.320.030	● 320	2,4/1,8	30/25,4	60 WWF	UNI 1 + UNI 2	69,85
108055.330.010	● 330	2,6/2,0	32/30	36 WZ	-	52,40
108055.330.020	● 330	2,6/2,0	32/30	54 WZ	UNI 2	66,45
108055.330.030	● 330	2,6/2,0	32/30	72 WWF	-	80,20
108055.350.010	● 350	2,6/2,0	30	36 WZ	UNI 1 + UNI 2	57,20
108055.350.020	● 350	2,6/2,0	30	54 WZ	UNI 1 + UNI 2	71,25
108055.350.030	● 350	2,6/2,0	30	72 WWF	UNI 1 + UNI 2	85,30
108055.355.010	● 355	2,6/2,0	30/25,4	36 WZ	UNI 1 + UNI 2	57,60
108055.355.020	● 355	2,6/2,0	30/25,4	54 WZ	UNI 1 + UNI 2	71,40
108055.355.030	● 355	2,6/2,0	30/25,4	72 WWF	UNI 1 + UNI 2	85,50
108055.400.010	● 400	2,8/2,2	30	42 WZ	UNI 1 + UNI 2	81,35
108055.400.020	● 400	2,8/2,2	30	60 WZ	UNI 1 + UNI 2	98,75
108055.400.030	● 400	2,8/2,2	30	84 WWF	UNI 1 + UNI 2	122,30
108055.420.010	● 420	2,8/2,2	30	42 WZ	UNI 1 + UNI 2	83,45
108055.420.020	● 420	2,8/2,2	30	60 WZ	UNI 1 + UNI 2	101,15
108055.420.030	● 420	2,8/2,2	30	84 WWF	UNI 1 + UNI 2	124,35
108055.450.010	● 450	3,2/2,5	30	48 WZ	UNI 1 + UNI 2	100,90
108055.450.020	● 450	3,2/2,5	30	72 WZ	UNI 1 + UNI 2	124,10
108055.450.030	● 450	3,2/2,5	30	96 WWF	UNI 1 + UNI 2	147,30
108055.500.010	● 500	3,4/2,8	30	54 WZ	UNI 1 + UNI 2	125,30
108055.500.020	● 500	3,4/2,8	30	84 WZ	UNI 1 + UNI 2	154,05
108055.500.030	● 500	3,4/2,8	30	108 WWF	UNI 1 + UNI 2	177,20

UNI 1 = 2-7-42 + 2-9-46,4 UNI 2 = 2-10-60 + 2-11-63 + 2-12-64 ● Gefertigt/Manufactured 232,50 mm



Art.
100
101
102

Aluminium · Kupfer · Messing · Bronze

Aluminium · Copper · Brass · Bronze

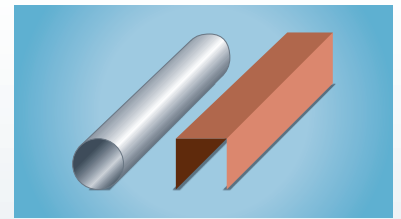

Schnittwertempfehlungen · Recommended cutting values

Werkstoffgruppe Material Group	Werkstoffbeispiele Material examples	Vc (m/s) Schnittgeschwindigkeit Cutting speed	fz (mm/z) Vorschub pro Zahn Feed per tooth
Al-Knetlegierungen Al wrought alloy	AlMn [AlMn1Cu] (3003), AlMg [AlMg2] (5251), AlCuMg [AlZnMg3Cu] (7022)	30-80 30-70	Profil · Profile Voll · Solid 0,005-0,03 0,02-0,07
Al-Gußlegierungen Al cast alloy	AlMg3 (51300), AlMg5Si (51400)	30-70	Profil · Profile Voll · Solid 0,005-0,03 0,02-0,07
Al-Gußlegierungen SI Al cast alloy SI	AlSi12	30-40	Profil · Profile Voll · Solid 0,005-0,02 0,01-0,05
Mg-Knetlegierungen Mg wrought alloy	MgMn2 (3.3520), MgAl3Zn (3.5312)	30-60	Profil · Profile Voll · Solid 0,005-0,02 0,01-0,05
Mg-Gußlegierungen Mg wrought alloy	MgAl8Zn1 (MC 2111 0), MgAl4Si	30-60 30-50	Profil · Profile Voll · Solid 0,005-0,02 0,01-0,05
Kupfer Copper	Cu58	7-14	Profil · Profile Voll · Solid 0,01-0,02 0,03-0,05
Messing Brass	CuZn40Pb, CuZn30	5-9	Profil · Profile Voll · Solid 0,01 0,03-0,05
Bronze Bronze	CuSn6, CuSn6Zn	3-7	Profil · Profile Voll · Solid 0,01-0,02 0,04-0,08

Drehzahl n (U/min) · Revolution per minute n (rpm)

	1500	2000	2500	2850	3000	4000	4500	5000	5600	6000	8000	9000	10000	12000	18000
80 Ø	6,5	8,5	10,5	12	13	17	19	21	23,5	26	34	38	42	52	76
90 Ø	7	9,5	12	13,5	14	19	21	24	26,5	28	38	42	48	56	84
100 Ø	8	10,5	13	15	16	21	24	26	29	32	42	48	52	54	96
120 Ø	9,5	13	16	18	19	26	28	32	35	38	52	56	64	76	112
125 Ø	10	13,5	16,5	18,5	19,5	27	29	33	36,5	39	54	59	66	78	118
140 Ø	11	15	18	21	22	30	33	36	41	44	60	66	72	88	132
150 Ø	12	15,5	19,5	22,5	23,5	31,5	33,5	39	44	47	63	70,5	78,5	94,5	141,5
160 Ø	13	17	21	24	26	34	38	42	47	52	68	76	84	104	152
180 Ø	14	19	24	27	28	38	42,5	48	53	56	76	85	96	118	170
200 Ø	16	21	26	30	32	42	47	52	58,5	64	84	94	104	128	188
225 Ø	18	24	30	33,5	36	48	58	60	66	72	96	106	120	144	212
250 Ø	20	26	33	37	40	52	59	66	73,5	80	104	118	132	160	236
300 Ø	24	31,5	40	45	48	63	71	80	88	96	126	142	160	192	284
350 Ø	28	36,5	47	52	56	73	88	94	105	112	146	166	188	224	332
400 Ø	32	42	54	60	64	84	94	108	117	128	168	188	216	256	376
450 Ø	35,5	47	59	67,5	70,5	94,5	106	118	132	141,6	188	211	236	283	424
500 Ø	40	53	67	74,5	80	106	118	134	146,5	160	212	236	268	320	472

Schnittgeschwindigkeit in m/s · Cutting speed in m/s

① NE-Metalle
Non ferrous metals

② Sicherheitsgrenze
Safety limits

Vc (m/s) = Schnittgeschwindigkeit · Cutting speed

Vf (m/min) = Vorschubgeschwindigkeit · Feed rate

fz (mm/z) = Vorschub pro Zahn · Feed per tooth

D (mm) = Sägendurchmesser · Saw blade diameter

n (min⁻¹) = Drehzahl · rpm

Z = Anzahl der Zähne · Number of teeth

Festlegung der Schnittgeschwindigkeit Vc
Determination of cutting speed Vc

$$Vc (m/s) = \frac{D \cdot \pi \cdot n}{60 \cdot 1000}$$

Festlegung der Vorschubgeschwindigkeit Vf
Determination of feed rate Vf

$$Vf (m/min) = \frac{fz \cdot n \cdot Z}{1000}$$



Art.
100
101
102

Aluminium · Kupfer · Messing · Bronze

Aluminium · Copper · Brass · Bronze

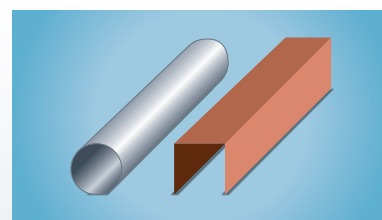

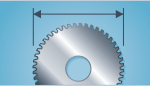
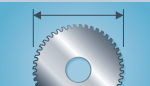
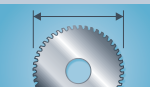
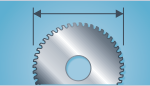
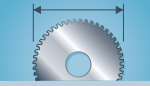
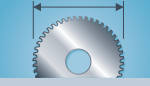
Art. Ø mm	Type	Anwendung · Application	
10.8000 Ø mm 120-300 	Aluminium Universal	Universalblatt für das Bauhandwerk, Ladenbau, Messebau, Renovierungsarbeiten	546
	Aluminium universal	Universal blade for the building trade, shop fitting, booth builder, renovations	
10.9000 Ø mm 350-400 	Alu 7-Zahn Geometrie	Durch 7-Zahn Geometrie hervorragende Schnittgüte, exakter Schnitt und höchste Standzeit	547
	Alu 7-tooth geometry	7-tooth geometry gives excellent cutting quality, precise cut and maximum tool life	
11.1000 Ø mm 200-600 	Aluminium Positiv	Plattenaufteilung und Kappschnitte in Profile, Platten, Blöcke, Stangen	549
	Aluminium positive	Sizing and cross cuts in profiles, plates, blocks and rods	
11.1050 Ø mm 250-550 	Aluminium Positiv Dünnschnitt	Plattenaufteilung und Kappschnitte in Profile, Platten, Blöcke, Stangen	551
	Aluminium positive thin-cut	Sizing and cross cuts in profiles, plates, blocks and rods	
11.1100 Ø mm 250-600 	Aluminium Negativ	Plattenaufteilung und Kappschnitte in dünnwandiges Profil und Vollmaterial	553
	Aluminium negative	Sizing and cross cuts in thin-walled profiles and solid materials	
11.1120 Ø mm 120-550 	Aluminium Negativ Dünnschnitt	Plattenaufteilung und Kappschnitte in dünnwandiges Profil und Vollmaterial	555
	Aluminium negative Thin-Cut	Sizing and cross cuts in thin-walled profiles and solid materials	

1



2



3



4



5



6



7



8



9



10



Art.
100
101
102

Art. **10.8000**

Aluminium Universal
Aluminium universal

GOLD-STAR LINE 

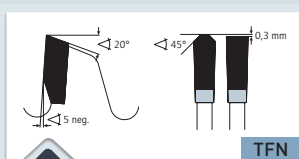

> Trapez-Flachzahn Negativ
> Triple-chip / flat tooth

TFN

MASCHINE · MACHINE

Für Elektro Handkreissägen, Tauchsägen, Kapp- und Gehrungssägen, Radialarmsägen, Tisch- und Formatkreissägen, Akkubetriebene Maschinen.

For portable circular saws, cross-cut saws, panel saws, sizing and mitre saws, table and radial arm saws, battery-driven saws.

✓ OPTIMAL · OPTIMAL ✓ GUT · GOOD ✓ MÖGLICH · POSSIBLE

✓		Ne-Metall wie Alu, Messing, Kupfer	Non ferrous materials like alu, copper, brass
✓		Kunststoffe, Plexiglas, Duro- und Thermoplaste	Plastics, plexiglass, acrylics, duro- and thermoplastics
✓		Dünnscheibe, Sandwich Material, Verbundstoffe	Thin iron sheets, sandwich material, composites
✓		Weichholz, Hartholz, Exotenholz, Quer	Soft wood, hard wood, and exotic wood across the grain
✓		Holz mit Einschlüssen wie Nägel, Klammern, Beton- und Mörtelreste	Wood with inclusions like nails, clips, concrete residues
✓		Gips-Zement-Steinwollplatten, Eternit, GFK, CFK, HPL, Mineralwerkstoffe	Gypsum/Cement fibre boards, Rockwool, Eternit, GRP, CFK, HPL, Mineral material
✓		Gasbetonsteine	Autoclaved aerated concrete blocks



ANWENDUNG · APPLICATION

Das ideale Blatt für den Ladenbau, Messebau, Renovierungsarbeiten. Für eine Vielzahl von Materialien wie: Ne-Metalle, Kunststoffe, Plexiglas, Spanplatten, Thermofassadenplatten.

Weitere Alu-Negativ Blätter siehe Art. 11.1100 Seite 553 sowie Art. 11.1120 Seite 555.

The ideal blade for shop construction, trade fair construction, renovation work. For many materials such as: non-ferrous materials, plastics, plexiglas, chipboard, thermo façade plates.

Other aluminium negative sheets: see item 11.1100 page 553, and item 11.1120 page 555.

Art.							€
108000.120.010	● 120	2,8/2,0	20	34 TFN	-	-	33,65
108000.136.010	● 136	2,8/2,0	20/10	40 TFN	2-6-32	-	39,30
108000.150.010	● 150	2,8/2,0	20/16	42 TFN	2-6-32	-	40,50
108000.160.010	● 160	2,8/2,0	20/16	42 TFN	2-6-32	-	40,95
108000.165.010	● 165	2,8/2,0	20	48 TFN	2-6-32	-	44,20
108000.170.010	● 170	2,8/2,0	30	48 TFN	-	-	44,35
108000.180.010	● 180	2,8/2,0	30	48 TFN	UNI 1	-	44,90
108000.185.010	● 185	2,8/2,0	20/16	48 TFN	2-6-32	-	46,55
108000.190.010	● 190	2,8/2,0	30	54 TFN	UNI 1	-	49,55
108000.200.010	● 200	2,8/2,0	30	54 TFN	UNI 1	-	50,55
108000.210.010	● 210	2,8/2,0	30	54 TFN	UNI 1	-	51,25
108000.216.010	● 216	2,8/2,0	30	60 TFN	UNI 1	-	56,45
108000.216.020	● 216	2,8/2,0	30	80 TFN	UNI 1	-	67,75
108000.220.010	● 220	2,8/2,0	30	54 TFN	UNI 1	-	54,15
108000.230.010	● 230/235	2,8/2,0	30	64 TFN	UNI 1	-	56,75
108000.240.010	● 240	2,8/2,0	30	64 TFN	UNI 1	-	56,75
108000.250.010	● 250	3,2/2,5	30	60 TFN	UNI 1 + UNI 2	✓	70,65
108000.250.020	● 250	3,2/2,5	30	80 TFN	UNI 1 + UNI 2	✓	78,70
108000.250.030	● 250	2,8/2,2	30	100 TFN	UNI 1 + UNI 2	✓	97,35
108000.260.010	● 260	3,2/2,5	30	80 TFN	UNI 1 + UNI 2	✓	85,10
108000.270.010	● 270	3,2/2,5	30	88 TFN	UNI 1 + UNI 2	✓	86,95
108000.280.010	● 280	3,2/2,5	30	88 TFN	UNI 1 + UNI 2	✓	89,15
108000.300.010	● 300	3,2/2,5	30	72 TFN	UNI 1 + UNI 2	✓	84,55
108000.300.020	● 300	3,2/2,5	30	96 TFN	UNI 1 + UNI 2	✓	88,55
108000.300.030	● 300	2,8/2,2	30	120 TFN	UNI 1 + UNI 2	✓	115,50

UNI 1 = 2-7-42 + 2-9-46,40 UNI 2 = 2-10-60 + 2-11-63 + 2-12-64

● Gefertigt/Manufactured 232,50 mm



Video



1



2



3



4



5



6



7



8



9



10



Art. 100 101 102





Aluminium 7-Zahn Geometrie
Aluminium 7-tooth geometry

Art. **10.9000**

GOLD-STAR LINE 



✓ OPTIMAL · OPTIMAL ✓ GUT · GOOD ✓ MÖGLICH · POSSIBLE

✓		Ne-Metall wie Alu, Messing, Kupfer	Non ferrous materials like alu, copper, brass
✓		Mineralische/acrylgebundene Massivplatten/Küchenplatten: Corian®, Noblan®, Hi-Macs®, Staron®, Rausolid®, Varicor®	Mineral/acrylic bound solid boards/kitchen worktops: Corian®, Noblan®, Hi-Macs®, Staron®, Rausolid®, Varicor®
✓		HPL-Duroplastische Schichtstoffplatten/Fassadenplatten: Trespa®, Resopal®, Duropal®, Formica®, Kronospan®, Decodur®	HPL High-Pressure-Laminate solid boards/façade panels: Trespa®, Resopal®, Duropal®, Formica®, Kronospan®, Decodur®
✓		Kunststoffe, Plexiglas, Duro- und Thermoplaste	Plastics, plexiglass, acrylics, duro- and thermoplastics

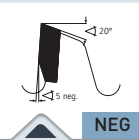
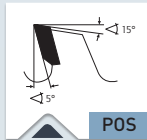
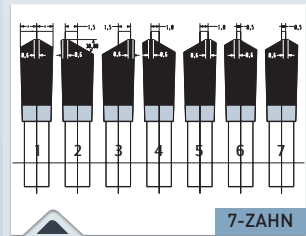

ANWENDUNG · APPLICATION







Durch 7-Zahn Geometrie hervorragende Schnittgüte, exakter Schnitt und höchste Standzeiten in sämtlichen Ne-Metallen, Acrylharzen (Plexiglas), Pertinax, Corian, Varicor, Resoplan u.ä.

Outstanding cut quality due to 7-Cut geometry, accurate cutting and the highest service life in all non-ferrous metals, acrylic resins (Plexiglas), Pertinax, Corian, Varicor, Resoplan and similar material.

MASCHINE · MACHINE

Für Tisch- und Formatkreissägen, Kapp- und Gehrungssägen, Radialssägen, Doppelabkürzsägen.

For table and sizing circular saws, panel and mitre saws, radial arm saws, cross cut saws.

Art.							€
109000.350.010	▲ 350	3,6/3,0	30	84 POS	UNI	✓	111,25
109000.400.010	▲ 400	4,0/3,2	30	70 POS	UNI	✓	124,90
109000.400.020	▲ 400	3,6/3,0	30	98 NEG	UNI	✓	146,30

UNI = 2-10-60 + 2-11-63 + 2-12-64

Weitere Abmessungen auf Anfrage. ▲ Solange Vorrat reicht.
Other dimensions are available on request ▲ While stocks last.



Video 

547

1



2



3



4



5



6



7



8



9



10



Art.
100
101
102

Karnasch® HARTMETALL-BESTÜCKTE KREISSÄGEBLÄTTER CARBIDE TIPPED CIRCULAR SAW BLADES

Art. **11.1000**

Aluminium Positiv
Aluminium positive

GOLD-STAR LINE 

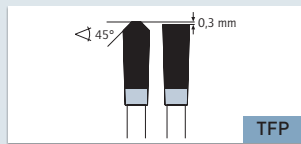
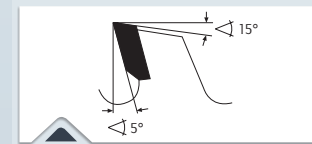





> Trapez-Flachzahn Positiv
> Triple-chip / flat tooth positive

MASCHINE · MACHINE

Tisch- und Formatkreissägen, Doppelgehrungssägen, Automatische Kappkreissägen, CNC-Bearbeitungszentren.

Double mitre saws, automatic cross-cut saws, sizing saws, CNC machining centers

✓ OPTIMAL · OPTIMAL ✓ GUT · GOOD ✓ MÖGLICH · POSSIBLE

✓		Ne-Metall wie Alu, Messing, Kupfer	Non ferrous materials like alu, copper, brass
✓		Kunststoffe, Plexiglas, Duro- und Thermoplaste	Plastics, plexiglass, acrylics, duro- and thermoplastics
✓		Mineralische/acrylgebundene Massivplatten/Küchenplatten: Corian®, Noblan®, Hi-Macs®, Staron®, Rausolid®, Varicor®	Mineral/acrylic bound solid boards/kitchen worktops: Corian®, Noblan®, Hi-Macs®, Staron®, Rausolid®, Varicor®
✓		HPL-Duroplastische Schichtstoffplatten/Fassadenplatten: Trespa®, Resopal®, Duropal®, Formica®, Kronospan®, Decodur®	HPL High-Pressure-Laminate solid boards/façade panels: Trespa®, Resopal®, Duropal®, Formica®, Kronospan®, Decodur®

ANWENDUNG · APPLICATION

Plattenaufteilung und Kappschnitte in Profile, Platten, Blöcke, Stangen aus NE-Metalle wie Aluminium, Messing, Kupfer sowie Kunststoffe (z.B. Fensterprofile).

Durch positiven Schnittwinkel vorzugsweise für automatischen Vorschub und dickere Wandstärken. (Auch manueller Vorschub möglich)

Spezialausführungen für eloxiertes oder lackiertes Aluminium auf Anfrage.

Sizing and cross cutting profiles, plates, blocks and rods made of aluminium, brass, copper and plastics (e.g. window profiles).

Due to positive cutting angle preferably for automatic feed and thicker walls. (Manual feed is also possible)

Special design for anodized or lacquered aluminum on request.

- 1 
- 2 
- 3 
- 4 
- 5 
- 6 
- 7 
- 8 
- 9 
- 10 

Art. 100 101 102



Aluminium Positiv
Aluminium positive

Art. 11.1000



Art.									€
111000.200.010	• 200	3,2/2,5	30	54 TFP	UNI 1 + UNI 2	-	-	-	67,15
111000.200.020	• 200	2,8/2,2	30	72 TFP	UNI 1 + UNI 2	-	-	-	79,10
111000.225.010	• 225	2,5/1,8	30	68 TFP	UNI 1 + UNI 2	-	-	-	74,80
111000.250.010	• 250	3,2/2,5	30	60 TFP	UNI 1 + UNI 2	✓	-	-	73,85
111000.250.020	• 250	3,2/2,5	30	80 TFP	UNI 1 + UNI 2	✓	-	-	82,75
111000.250.030	• 250	3,2/2,5	32	80 TFP	UNI 2	✓	-	-	82,75
111000.275.010	• 275	3,2/2,5	40	72 TFP	2-9-55+4-12-64	✓	-	-	88,50
111000.280.010	• 280	3,2/2,5	30	68 TFP	UNI 1 + UNI 2	✓	-	-	89,30
111000.280.020	• 280	3,2/2,5	30	96 TFP	UNI 1 + UNI 2	✓	-	-	93,70
111000.300.010	• 300	3,2/2,5	30	72 TFP	UNI 1 + UNI 2	✓	-	-	89,30
111000.300.020	• 300	3,2/2,5	30	96 TFP	UNI 1 + UNI 2	✓	-	-	93,70
111000.300.030	• 300	3,2/2,5	32	72 TFP	UNI 2	✓	-	-	89,30
111000.300.040	• 300	3,2/2,5	32	96 TFP	UNI 2	✓	-	-	93,70
111000.300.050	• 300	3,2/2,5	40	96 TFP	2-9-55+4-12-64	✓	-	-	107,50
111000.320.010	• 320	3,2/2,5	30	84 TFP	UNI 1 + UNI 2	✓	-	-	104,50
111000.330.010	• 330	3,2/2,5	32/30	72 TFP	UNI 2	✓	-	-	95,55
111000.330.020	• 330	3,2/2,5	32/30	96 TFP	UNI 2	✓	-	-	115,85
111000.350.010	▲ 350	4,0/3,2	30	54 TFP	UNI 1 + UNI 2	✓	-	-	91,55
111000.350.020	• 350	3,4/2,8	30	72 TFP	UNI 1 + UNI 2	✓	-	-	100,80
111000.350.030	• 350	3,4/2,8	30	92 TFP	UNI 1 + UNI 2	✓	-	-	116,70
111000.350.040	• 350	3,4/2,8	30	108 TFP	UNI 1 + UNI 2	✓	-	-	129,80
111000.350.050	• 350	3,4/2,8	32	92 TFP	UNI 2	✓	-	-	116,70
111000.350.060	• 350	3,4/2,8	32	108 TFP	UNI 2	✓	-	-	123,30
111000.350.070	• 350	3,4/2,8	40	92 TFP	2-9-55+4-12-64	✓	-	-	116,70
111000.350.080	• 350	3,4/2,8	40	108 TFP	2-9-55+4-12-64	✓	-	-	129,80
111000.370.010	• 370	3,6/3,0	30	96 TFP	UNI 1 + UNI 2	✓	-	-	134,95
111000.400.010	• 400	3,8/3,2	30	72 TFP	UNI 1 + UNI 2	✓	✓	-	138,10
111000.400.020	• 400	3,8/3,2	30	96 TFP	UNI 1 + UNI 2	✓	✓	-	158,90
111000.400.030	• 400	3,8/3,2	30	120 TFP	UNI 1 + UNI 2	✓	✓	-	179,70
111000.400.040	• 400	3,8/3,2	32	96 TFP	UNI 2	✓	✓	-	158,90
111000.400.050	• 400	3,8/3,2	40	96 TFP	4-12-64+2-15-80	✓	✓	-	158,90
111000.400.060	• 400	3,8/3,2	40	120 TFP	4-12-64+2-15-80	✓	✓	-	179,70
111000.400.070	• 400	3,8/3,2	50	96 TFP	4-15-80	✓	✓	-	158,90
111000.400.080	• 400	3,8/3,2	50	120 TFP	4-15-80	✓	✓	-	179,70
111000.420.010	• 420	4,0/3,2	30	72 TFP		✓	✓	-	151,40
111000.420.020	• 420	4,0/3,2	30	96 TFP	2-9-46,4 + UNI 2	✓	✓	-	160,10
111000.420.030	• 420	4,0/3,2	30	120 TFP	+ 2-10,5-70	✓	✓	-	180,95
111000.430.010	• 430	4,0/3,2	30	96 TFP		✓	✓	-	167,15
111000.450.010	• 450	4,0/3,2	30	72 TFP	UNI 1 + UNI 2 + 2-10,5-70	✓	✓	-	154,30
111000.450.020	• 450	4,0/3,2	30	108 TFP	UNI 1 + UNI 2 + 2-10,5-70	✓	✓	-	170,50
111000.450.030	• 450	4,0/3,2	30	120 TFP	UNI 1 + UNI 2 + 2-10,5-70	✓	✓	-	185,75
111000.450.040	• 450	4,0/3,2	32	96 TFP	UNI 2	✓	✓	-	161,65
111000.450.050	• 450	4,0/3,2	32	120 TFP	UNI 2	✓	✓	-	185,75
111000.500.010	• 500	4,2/3,6	30	72 TFP		✓	✓	-	163,15
111000.500.020	• 500	4,2/3,6	30	96 TFP	2-9-46,4 + UNI 2	✓	✓	-	183,30
111000.500.030	• 500	4,2/3,6	30	120 TFP	+ 2-10,5-70	✓	✓	-	206,65
111000.500.040	• 500	4,2/3,6	30	144 TFP		✓	✓	-	232,65
111000.500.050	• 500	4,2/3,6	32	120 TFP	UNI 2	✓	✓	-	206,65
111000.500.060	• 500	4,2/3,6	32	144 TFP	UNI 2	✓	✓	-	232,65
111000.550.010	• 550	4,4/3,8	30	72 TFP		✓	✓	-	254,00
111000.550.020	• 550	4,4/3,8	30	110 TFP	2-9-46,4 + UNI 2	✓	✓	-	282,40
111000.550.030	• 550	4,4/3,8	30	144 TFP	+ 2-10,5-70	✓	✓	-	336,75
111000.550.040	• 550	4,4/3,8	32	96 TFP	UNI 2	✓	✓	-	262,50
111000.550.050	• 550	4,4/3,8	32	128 TFP	UNI 2	✓	✓	-	297,90
111000.550.060	• 550	4,4/3,8	80	128 TFP	6-9-100	✓	✓	-	304,05
111000.600.010	• 600	4,6/4,0	30	140 TFP	UNI 1 + UNI 2	✓	✓	-	378,25

▲ = Auslaufartikel / Discontinued

UNI 1 = 2-7-42+2-9-46,4 UNI 2 = 2-10-60+2-11-63+2-12-64

Weitere Alu-Positiv-Blätter S. 551 · More Alu-Positive blades page 551



Art.
100
101
102



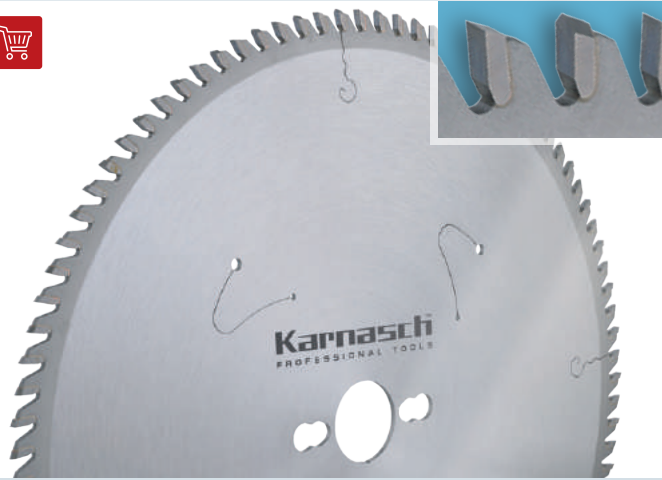

Art. **11.1050**

Aluminium Positiv Dünnschnitt
Aluminium positive thin-cut

GOLD-STAR LINE 



✓ OPTIMAL · OPTIMAL ✓ GUT · GOOD ✓ MÖGLICH · POSSIBLE

✓		Ne-Metall wie Alu, Messing, Kupfer	Non ferrous materials like alu, copper, brass
✓		Kunststoffe, Plexiglas, Duro- und Thermoplaste	Plastics, plexiglass, acrylics, duro- and thermoplastics
✓		Mineralische/acrylgebundene Massivplatten/Küchenplatten: Corian®, Noblan®, Hi-Macs®, Staron®, Rausolid®, Varicor®	Mineral/acrylic bound solid boards/kitchen worktops: Corian®, Noblan®, Hi-Macs®, Staron®, Rausolid®, Varicor®
✓		HPL-Duroplastische Schichtstoffplatten/Fassadenplatten: Trespa®, Resopal®, Duropal®, Formica®, Kronospan®, Decodur®	HPL High-Pressure-Laminate solid boards/façade panels: Trespa®, Resopal®, Duropal®, Formica®, Kronospan®, Decodur®

1



2



3



4



5



6



7



8



9



10

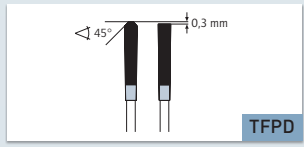
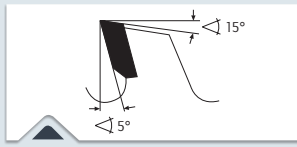

> Trapez-Flachzahn Positiv dünn
> Triple-chip / flat tooth thin positive

MASCHINE · MACHINE

Akkubetriebene Sägemaschinen, Tisch- und Formatkreissägen, automatische Kappkreissägen, CNC-Bearbeitungszentren.

Battery-driven saws, table and sizing saws, automatic cross-cut saws, CNC machining centers, bench saws.

ANWENDUNG · APPLICATION

Plattenaufteilung und Kappschnitte in Profile, Platten, Blöcke, Stangen aus NE-Metalle wie Aluminium, Messing, Kupfer sowie Kunststoffe.

Durch dünne Schnittbreite wenig Kraftaufwand und Verschnitt. Daher ideal auch für akkubetriebene Maschinen.

Durch positiven Schnittwinkel vorzugsweise für automatischen Vorschub. (Auch manueller Vorschub möglich)

Spezialausführungen für eloxiertes oder lackiertes Aluminium auf Anfrage.

Sizing and cross cuts profiles, plates, blocks and rods made of aluminium, brass, copper and plastics.

Due to the small cutting width less cutting pressure and cutting waste. Therefore ideal also for battery-powered machines.

Due to positive cutting angle preferably for automatic feed. (Manual feed is also possible)







Special design for anodized or lacquered aluminum on request.

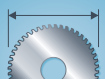

Aluminium Positiv Dünnschnitt
Aluminium positive thin-cut

Art. 11.1050

GOLD-STAR LINE ★

Art.								€
111050.250.010	• 250	2,4/1,8	30	100 TFPD	UNI 1 + UNI 2	✓	-	97,40
111050.300.010	• 300	2,4/1,8	30	120 TFPD	UNI 1 + UNI 2	✓	-	115,50
111050.350.010	• 350	2,7/2,0	30	120 TFPD	UNI 1 + UNI 2	✓	-	136,80
111050.400.010	• 400	3,1/2,5	30	128 TFPD	UNI 1 + UNI 2	✓	✓	153,40
111050.420.010	• 420	3,4/2,8	30	132 TFPD	2-9-46,4 + UNI 2 + 2-10,5-70	✓	✓	175,90
111050.450.010	• 450	3,4/2,8	30	138 TFPD	2-9-46,4 + UNI 2 + 2-10,5-70	✓	✓	182,60
111050.500.010	• 500	3,4/2,8	30	144 TFPD	2-9-46,4 + UNI 2 + 2-10,5-70	✓	✓	202,05
111050.550.010	• 550	3,6/3,0	30	160 TFPD	2-9-46,4 + UNI 2 + 2-10,5-70	✓	✓	278,90

UNI 1 = 2-7-42 + 2-9-46,40 UNI 2 = 2-10-60 + 2-11-63 + 2-12-64

Weitere Abmessungen für dünne Profile bis 1mm Wandstärke aus Nicht-Eisen-Metalle, wie Alu, Kupfer, Messing, siehe Artikel 11.1430 Seite 631
Further dimension for thin profiles up to 1mm wall thickness made of non-ferrous metal such as aluminum, copper, brass, see article 11.1430 page 631

Für den perfekten Schnitt
gibt es nur einen Versuch.

There is only one trial for
the perfect cut.

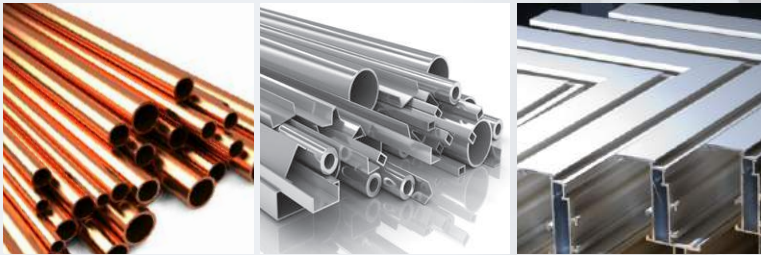

POWER.
PRECISION.
PERFORMANCE.



Karnasch®
PROFESSIONAL TOOLS

- 1 
- 2 
- 3 
- 4 
- 5 
- 6 
- 7 
- 8 
- 9 
- 10 

Art.
100
101
102



Art. **11.1100**

Aluminium Negativ
Aluminium negative

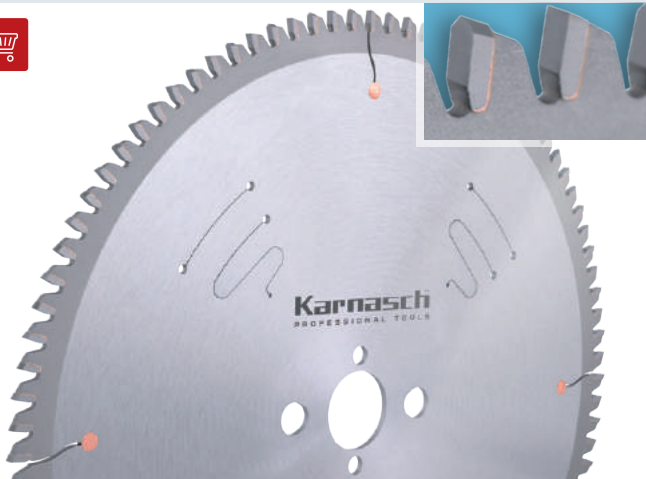
GOLD-STAR LINE 



✓ OPTIMAL · OPTIMAL ✓ GUT · GOOD ✓ MÖGLICH · POSSIBLE

✓		Ne-Metall wie Alu, Messing, Kupfer	Non ferrous materials like alu, copper, brass
✓		Kunststoffe, Plexiglas, Duro- und Thermoplaste	Plastics, plexiglass, acrylics, duro- and thermoplastics

ANWENDUNG · APPLICATION

Plattenaufteilung und Kappschnitte in dünnwandiges Profil und Vollmaterial aus NE-Metalle wie Aluminium, Kupfer, Messing sowie Kunststoffe (z.B. Fensterprofile).

Minimalmengenschmierung empfohlen.

Durch negativen Spanwinkel vorzugsweise manueller Vorschub.

Automatischer Vorschub ebenfalls möglich.

Spezialausführungen für eloxiertes oder lackiertes Aluminium auf Anfrage.

Sizing and cross cuts in thin-walled profiles, plates, blocks and rods made of aluminium, brass, copper and plastics (e.g. window profiles).

Minimum Lubrication recommended.

Because of negative hook angle preferably for manual feed.

Automatic feed also possible.

Special design for anodized or lacquered aluminum on request.

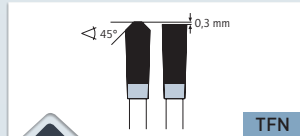
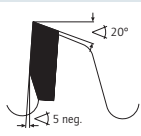

> Trapez-Flachzahn Negativ
> Triple-chip / flat tooth negative

MASCHINE · MACHINE

Abläng- und Kappsägen, Tisch- und Formatkreissägen, Gehrungs- und Doppelgehrungssägen, Kappkreissägen, CNC-Bearbeitungszentren, Radialarmsägen.

Mitre and double mitre saws, table and sizing saws, cross-cut saws, CNC machining centers, Radial arm saws.



Art. 100, 101, 102









Video 

Aluminium Negativ
Aluminium negative

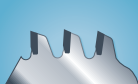
Art. 11.1100

GOLD-STAR LINE 

Art.								€
111100.250.010	● 250	3,2/2,5	30	60 TFN	UNI 1 + UNI 2	✓	-	73,85
111100.250.020	● 250	3,2/2,5	30	80 TFN	UNI 1 + UNI 2	✓	-	82,75
111100.250.030	● 250	2,8/2,2	30	80 TFN	UNI 1 + UNI 2	✓	-	73,75
111100.250.040	● 250	2,8/2,2	30	100 TFN	UNI 1 + UNI 2	✓	-	88,65
111100.250.050	● 250	3,2/2,5	32	60 TFN	UNI 2	✓	-	73,85
111100.250.060	● 250	3,2/2,5	32	80 TFN	UNI 2	✓	-	82,75
111100.250.070	● 250	3,2/2,5	32	100 TFN	UNI 2	✓	-	110,25
111100.275.010	● 275	3,2/2,5	40	88 TFN	2-9-55+4-12-64	✓	-	100,95
111100.275.020	● 275	3,2/2,5	40	110 TFN	2-9-55+4-12-64	✓	-	126,90
111100.280.010	● 280	3,2/2,5	30	88 TFN	UNI 1 + UNI 2	✓	-	100,95
111100.300.010	● 300	3,2/2,5	30	72 TFN	UNI 1 + UNI 2	✓	-	89,30
111100.300.020	● 300	3,2/2,5	30	96 TFN	UNI 1 + UNI 2	✓	-	93,70
111100.300.030	● 300	2,8/2,2	30	120 TFN	UNI 1 + UNI 2	✓	-	123,65
111100.300.040	● 300	3,2/2,5	32	72 TFN	UNI 2	✓	-	89,30
111100.300.050	● 300	3,2/2,5	32	96 TFN	UNI 2	✓	-	100,15
111100.300.060	● 300	2,8/2,2	32	120 TFN	UNI 2	✓	-	123,65
111100.300.070	● 300	3,2/2,5	40	72 TFN	2-9-55+4-12-64	✓	-	89,30
111100.300.080	● 300	3,2/2,5	40	96 TFN	2-9-55+4-12-64	✓	-	107,50
111100.305.010	● 305	3,2/2,5	30	96 TFN	UNI 1 + UNI 2	✓	-	108,55
111100.330.010	● 330	3,2/2,5	30	72 TFN	UNI 1 + UNI 2	✓	-	99,05
111100.330.020	● 330	3,2/2,5	30	96 TFN	UNI 1 + UNI 2	✓	-	113,40
111100.330.030	● 330	2,8/2,2	30	120 TFN	UNI 1 + UNI 2	✓	-	133,60
111100.330.040	● 330	3,2/2,5	32	72 TFN	UNI 2	✓	-	99,05
111100.330.050	● 330	3,2/2,5	32	96 TFN	UNI 2	✓	-	113,40
111100.330.060	● 330	2,8/2,2	32	120 TFN	UNI 2	✓	-	133,60
111100.350.010	● 350	3,4/2,8	30	90 TFN	UNI 1 + UNI 2	✓	-	115,20
111100.350.020	● 350	3,4/2,8	30	108 TFN	UNI 1 + UNI 2	✓	-	123,30
111100.350.030	● 350	3,2/2,5	30	140 TFN	UNI 1 + UNI 2	✓	-	148,40
111100.350.040	● 350	3,4/2,8	32	90 TFN	UNI 2	✓	-	116,00
111100.350.050	● 350	3,4/2,8	32	108 TFN	UNI 2	✓	-	129,80
111100.350.060	● 350	3,4/2,8	40	84 TFN	2-9-55+4-12-64	✓	-	109,90
111100.350.070	● 350	3,4/2,8	40	108 TFN	2-9-55+4-12-64	✓	-	129,80
111100.350.080	● 350	3,4/2,8	50	84 TFN	4-15-80	✓	-	109,90
111100.350.090	● 350	3,4/2,8	50	108 TFN	4-15-80	✓	-	127,55
111100.370.010	● 370	3,6/3,0	30	90 TFN	UNI 1 + UNI 2	✓	-	137,55
111100.370.020	● 370	3,6/3,0	30	108 TFN	UNI 1 + UNI 2	✓	-	149,25
111100.380.010	● 380	3,8/3,2	32	90 TFN	UNI 2	✓	-	137,55
111100.380.020	● 380	3,8/3,2	32	110 TFN	UNI 2	✓	-	149,25
111100.380.030	● 380	3,8/3,2	32	132 TFN	UNI 2	✓	-	181,65
111100.400.010	● 400	3,8/3,2	30	96 TFN	UNI 1 + UNI 2	✓	✓	158,90
111100.400.020	● 400	3,8/3,2	30	108 TFN	UNI 1 + UNI 2	✓	✓	172,10
111100.400.030	● 400	3,8/3,2	30	120 TFN	UNI 1 + UNI 2	✓	✓	179,70
111100.400.040	● 400	3,8/3,2	32	96 TFN	UNI 2	✓	✓	158,90
111100.400.050	● 400	3,8/3,2	32	108 TFN	UNI 2	✓	✓	172,10
111100.400.060	● 400	3,8/3,2	32	120 TFN	UNI 2	✓	✓	179,70
111100.400.070	● 400	3,8/3,2	40	96 TFN	4-12-64+2-15-80	✓	✓	158,90
111100.400.080	● 400	3,8/3,2	40	120 TFN	4-12-64+2-15-80	✓	✓	179,70
111100.400.090	● 400	3,8/3,2	50	96 TFN	4-15-80	✓	✓	179,70
111100.400.100	● 400	3,8/3,2	50	120 TFN	4-15-80	✓	✓	181,40
111100.420.010	● 420	4,0/3,2	30	96 TFN		✓	✓	160,10
111100.420.020	● 420	4,0/3,2	30	108 TFN	2-9-46,4 + UNI 2 + 2-10,5-70	✓	✓	170,50
111100.420.030	● 420	4,0/3,2	30	120 TFN		✓	✓	180,95
111100.420.040	● 420	4,0/3,2	40	96 TFN	4-12-64+2-15-80	✓	✓	160,10
111100.420.050	● 420	4,0/3,2	40	108 TFN	4-12-64+2-15-80	✓	✓	170,50
111100.420.060	● 420	4,0/3,2	40	120 TFN	4-12-64+2-15-80	✓	✓	180,95
111100.450.010	● 450	4,0/3,2	30	108 TFN		✓	✓	180,95
111100.450.020	● 450	4,0/3,2	30	128 TFN	2-9-46,4 + UNI 2 + 2-10,5-70	✓	✓	189,40
111100.500.010	● 500	4,2/3,6	30	120 TFN	2-9-46,4 + UNI 2 + 2-10,5-70	✓	✓	206,65
111100.500.020	● 500	4,2/3,6	30	140 TFN	2-9-46,4 + UNI 2 + 2-10,5-70	✓	✓	226,20
111100.520.010	● 520	4,2/3,6	30	120 TFN	-	✓	✓	276,80
111100.550.010	● 550	4,4/3,8	30	108 TFN		✓	✓	268,75
111100.550.020	● 550	4,4/3,8	30	132 TFN	2-9-46,4 + UNI 2 + 2-10,5-70	✓	✓	301,00
111100.600.010	● 600	4,6/4,0	30	140 TFN	UNI 1 + UNI 2	✓	✓	378,25

UNI 1 = 2-7-42 + 2-9-46,40 UNI 2 = 2-10-60 + 2-11-63 + 2-12-64

Weitere Aluminium Negativ-Blätter siehe S. 555/561 · More Aluminium Negativ blades see page 555/561



Art. **11.1120**

Aluminium Negativ Dünnschnitt
Aluminium negative Thin-Cut

GOLD-STAR LINE 

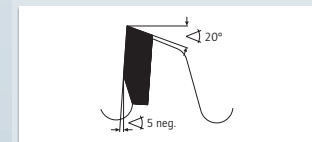

> Trapez-Flachzahn Negativ Dünn
> Triple chip / flat tooth thin negative

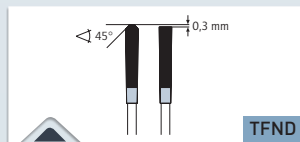



TFND

MASCHINE - MACHINE

Abläng- und Kappsägen, Tisch- und Formatkreissägen, Gehrungs- und Doppelgehrungssägen, Kappkreissägen, CNC-Bearbeitungszentren, Radialarmsägen, Handkreissägen, Tauchsägen, Akkubetriebene Sägemaschinen

Mitre and double mitre saws, table and sizing saws, cross-cut saws, CNC machining centers, portable circular saws, battery-driven saws

✓ OPTIMAL · OPTIMAL ✓ GUT · GOOD ✓ MÖGLICH · POSSIBLE

✓		Ne-Metall wie Alu, Messing, Kupfer	Non ferrous materials like alu, copper, brass
✓		Kunststoffe, Plexiglas, Duro- und Thermoplaste	Plastics, plexiglass, acrylics, duro- and thermoplastics

ANWENDUNG - APPLICATION

Plattenaufteilung und Kappschnitte in dünnwandige Profile und Vollmaterial aus NE-Metallen wie Aluminium, Kupfer, Messing sowie Kunststoffe (z.B. Fensterprofile).

Minimalmengenschmierung empfohlen.

Durch dünne Schnittbreite wenig Kraftaufwand und Verschnitt. Daher ideal auch für akkubetriebene Maschinen.

Durch negativen Spanwinkel vorzugsweise manueller Vorschub. Automatischer Vorschub ebenfalls möglich.

Spezialausführungen für eloxiertes oder lackiertes Aluminium auf Anfrage.

Sizing and cross cuts in thin-walled profiles, plates, blocks and rods made of aluminium, brass, copper and plastics (e.g. window profiles).

Minimum Lubrication recommended.

Due to the small cutting width less cutting pressure and cutting waste. Therefore ideal also for battery-powered machines.

Due to negative cutting angle preferably for manual feed. Automatic feed also possible.

Special design for anodized or lacquered aluminum on request.

1 

2 

3 

4 

5 

6 

7 

8 

9 

10 

Art. 100 101 102









Video 

Aluminium Negativ Dünnschnitt
Aluminium negative Thin-Cut

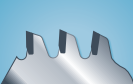
Art. 11.1120

GOLD-STAR LINE 

Art.								€
111120.120.010	• 120	2,2/1,6	20	36 TFND	-	-	-	38,15
111120.136.010	• 136	2,2/1,6	20/10	40 TFND	2-6-32	-	-	39,20
111120.150.010	• 150	2,4/1,6	20/16	42 TFND	2-6-32	-	-	39,65
111120.160.010	• 160	2,4/1,8	20/16	42 TFND	2-6-32	-	-	40,95
111120.160.020	• 160	2,2/1,6	20/16	60 TFND	2-6-32	-	-	54,45
111120.160.030	• 160	2,4/1,8	30	42 TFND	UNI 1	-	-	40,20
111120.170.010	• 170	2,4/1,8	30	48 TFND	UNI 1	-	-	44,60
111120.180.010	• 180	2,4/1,8	30	48 TFND	UNI 1	-	-	44,60
111120.180.020	• 180	2,2/1,6	30	64 TFND	UNI 1	-	-	58,10
111120.185.010	• 185	2,2/1,6	20/16	64 TFND	2-6-32	✓	-	58,90
111120.190.010	• 190	2,4/1,8	30	54 TFND	UNI 1	-	-	48,95
111120.190.020	• 190	2,2/1,6	30	68 TFND	UNI 1	-	-	61,80
-	• 200	2,2/1,8	20	100 TFND	Siehe/See Art. 11.1150, Seite/Page 671			-
111120.200.010	• 200	2,4/1,8	30	54 TFND	UNI 1	-	-	49,45
111120.200.020	• 200	2,2/1,6	30	68 TFND	UNI 1	✓	-	62,65
-	• 200	2,2/1,8	30	100 TFND	Siehe/See Art. 11.1150, Seite/Page 671			-
-	• 200	2,2/1,8	32	100 TFND	Siehe/See Art. 11.1150, Seite/Page 671			-
111120.210.010	• 210	2,4/1,8	30	54 TFND	UNI 1	-	-	50,05
111120.210.020	• 210	2,2/1,6	30	72 TFND	UNI 1	-	-	66,65
111120.216.010	• 216	2,4/1,8	30	60 TFND	UNI 1	-	-	55,15
111120.216.020	• 216	2,2/1,6	30	80 TFND	UNI 1	-	-	73,60
111120.220.010	• 220	2,4/1,8	30	64 TFND	UNI 1	-	-	56,80
111120.220.020	• 220	2,2/1,6	30	80 TFND	UNI 1	-	-	73,60
111120.225.010	• 225	2,4/1,8	30	64 TFND	UNI 1	-	-	56,80
111120.225.020	• 225	2,2/1,6	30	80 TFND	UNI 1	-	-	73,60
111120.230.010	• 230/235	2,4/1,8	30	64 TFND	UNI 1	-	-	56,80
111120.230.020	• 230/235	2,2/1,6	30	80 TFND	UNI 1	-	-	73,60
111120.240.010	• 240	2,2/1,8	30	80 TFND	UNI 1	-	-	73,60
111120.250.010	• 250	2,8/2,2	30	80 TFND	UNI 1 + UNI 2	✓	-	73,75
111120.250.020	• 250	2,2/1,8	30	100 TFND	UNI 1 + UNI 2	✓	-	97,40
111120.250.030	• 250	2,2/1,8	32/30	120 TFND	UNI 2	✓	-	134,10
111120.260.010	• 260	2,4/1,8	30	68 TFND	UNI 1 + UNI 2	✓	-	74,35
111120.260.020	• 260	2,4/1,8	30	100 TFND	UNI 1 + UNI 2	✓	-	105,35
111120.270.010	• 270	2,4/1,8	30	80 TFND	UNI 1 + UNI 2	✓	-	79,55
111120.270.020	• 270	2,4/1,8	30	100 TFND	UNI 1 + UNI 2	✓	-	107,60
111120.300.010	• 300	2,4/1,8	30	120 TFND	UNI 1 + UNI 2	✓	-	115,50
111120.305.010	• 305	2,6/2,0	30	80 TFND	UNI 1 + UNI 2	✓	-	88,65
111120.305.020	• 305	2,4/1,8	30	120 TFND	UNI 1 + UNI 2	✓	-	115,50
111120.330.010	• 330	2,4/1,8	30	96 TFND	UNI 1 + UNI 2	✓	-	122,65
111120.330.020	• 330	2,4/1,8	30	120 TFND	UNI 1 + UNI 2	✓	-	131,25
111120.330.030	• 330	2,4/1,8	32	96 TFND	UNI 2	✓	-	122,65
111120.330.040	• 330	2,4/1,8	32	120 TFND	UNI 2	✓	-	131,25
111120.350.010	• 350	2,7/2,0	30	120 TFND	UNI 1 + UNI 2	✓	-	136,80
111120.400.010	• 400	3,1/2,5	30	130 TFND	UNI 1 + UNI 2	✓	✓	153,40
111120.420.010	• 420	3,4/2,8	30	132 TFND	2-9-46,4 + UNI 2 + 2-10,5-70	✓	✓	175,90
111120.450.010	• 450	3,4/2,8	30	138 TFND	2-9-46,4 + UNI 2 + 2-10,5-70	✓	✓	182,60
111120.500.010	• 500	3,4/2,8	30	144 TFND	2-9-46,4 + UNI 2 + 2-10,5-70	✓	✓	202,05
111120.550.010	• 550	3,6/3,0	30	160 TFND	2-9-46,4 + UNI 2 + 2-10,5-70	✓	✓	278,90

• Gefertigt/Manufactured 232,50 mm

UNI 1 = 2-7-42 + 2-9-46,40 UNI 2 = 2-10-60 + 2-11-63 + 2-12-64



Art.
100
101
102

Kunststoffe

Plastics

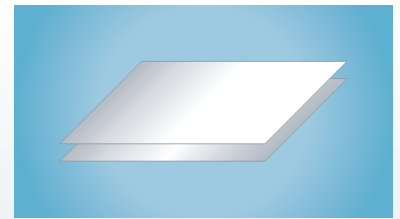

Drehzahl **n** (U/min) • Revolution per minute **n** (rpm)

	1500	2000	2500	2850	3000	4000	4500	5000	5600	6000	8000	9000	10000	12000	18000
80 Ø	6,5	8,5	10,5	12	13	17	19	21	23,5	26	34	38	42	52	76
90 Ø	7	9,5	12	13,5	14	19	21	24	26,5	28	38	42	48	56	84
100 Ø	8	10,5	13	15	16	21	24	26	29	32	42	48	52	54	96
120 Ø	9,5	13	16	18	19	26	28	32	35	38	52	56	64	76	112
125 Ø	10	13,5	16,5	18,5	19,5	27	29	33	36,5	39	54	59	66	78	118
140 Ø	11	15	18	21	22	30	33	36	41	44	60	66	72	88	132
150 Ø	12	15,5	19,5	22,5	23,5	31,5	33,5	39	44	47	63	70,5	78,5	94,5	141,5
160 Ø	13	17	21	24	26	34	38	42	47	52	68	76	84	104	152
180 Ø	14	19	24	27	28	38	42,5	48	53	56	76	85	96	118	170
200 Ø	16	21	26	30	32	42	47	52	58,5	64	84	94	104	128	188
225 Ø	18	24	30	33,5	36	48	58	60	66	72	96	106	120	144	212
250 Ø	20	26	33	37	40	52	59	66	73,5	80	104	118	132	160	236
300 Ø	24	31,5	40	45	48	63	71	80	88	96	126	142	160	192	284
350 Ø	28	36,5	47	52	56	73	88	94	105	112	146	166	188	224	332
400 Ø	32	42	54	60	64	84	94	108	117	128	168	188	216	256	376
450 Ø	35,5	47	59	67,5	70,5	94,5	106	118	132	141,6	188	211	236	283	424
500 Ø	40	53	67	74,5	80	106	118	134	146,5	160	212	236	268	320	472

Schnittgeschwindigkeit in m/s · Cutting speed in m/s

1 Kunststoffe
Plastics

2 Sicherheitsgrenze
Safety limits

Festlegung der Schnittgeschwindigkeit Vc
Determination of cutting speed Vc

$$Vc (m/s) = \frac{D \cdot \pi \cdot n}{60 \cdot 1000}$$

Festlegung der Vorschubgeschwindigkeit Vf
Determination of feed rate Vf

$$Vf (m/min) = \frac{fz \cdot n \cdot Z}{1000}$$

Vc (m/s) = Schnittgeschwindigkeit · Cutting speed

Vf (m/min) = Vorschubgeschwindigkeit · Feed rate

fz (mm/z) = Vorschub pro Zahn · Feed per tooth

D (mm) = Sägendurchmesser · Saw blade diameter

n (min⁻¹) = Drehzahl · rpm

Z = Anzahl der Zähne · Number of teeth



Art.
100
101
102

Kunststoffe

Plastics

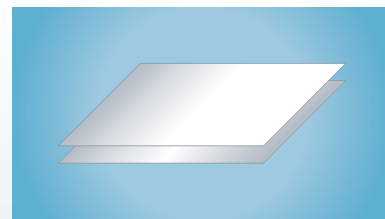

Schnittwertempfehlungen · Recommended cutting values

Werkstoffgruppe Material Group	Werkstoffbeispiele Material examples	Vc (m/min) Schnittgeschwindigkeit Cutting speed	fz (mm/z) Vorschub pro Zahn Feed per tooth
Harte Thermoplaste	PA Polyamid, PE Polyäthylen, PS Polystyrol, POM Polyoxymethylen, ABS Acrylnitril-Butadien-Styrol	60-70	0,06-0,10
	PVC Polyvinylchlorid	55-60	0,06-0,10
	PC Polycarbonat	70-75	0,03-0,06
Hard Thermoplastics	PA Polyamide, PE Polyethylene, PS Polystyrene, POM polyoxymethylene, ABS acrylonitrile-butadiene-styrene	60-70	0,06-0,10
	PVC Polyvinyl chloride	55-60	0,06-0,10
	PC Polycarbonat	70-75	0,03-0,06
Leicht schmelzende Thermoplaste	PP Polypropylen, PA6 Polyamid-6	60-70	0,08-0,18
Easily melting thermoplastics	PP polypropylene, PA6 polyamide-6		
Thermoplaste mit Sichtflächen	PC Polycarbonat	70-75	0,03-0,06
	PMMA Acrylglas	60-65	0,06-0,09
Thermoplastics with visible surface	PC polycarbonate	70-75	0,03-0,06
	PMMA acrylic glass	60-65	0,06-0,09
Duroplaste	HPL-Schichtstoffplatten (Trespa®, Resopal®, Wodego®, Duropal®, Formica®, Unilin®, Kronospan®, Homapal®, Decodur®, Abet®) PUR Polyurethan, Melamin, HP-Hartpapier	50-70	0,01-0,08
Duroplastic	HPL High-Pressure-Laminate (Trespa®, Resopal®, Wodego®, Duropal®, Formica®, Unilin®, Kronospan®, Homapal®, Decodur®, Abet®) PUR Polyurethan, Melamine, HP Hardpaper		
	Glasfaserverstärkte und Kohlefaserverstärkte Kunststoffe GFK/CFK Aramidfaserkunststoffe AFK (Kevlar, Nomex, Carbolan, Rigator, Durostone)	20-50	0,01-0,03
	Glass fibre and carbon fibre reinforced plastic GFK/CFK Aramid fibre plastik AFK (Kevlar, Nomex, Carbolan, Rigator, Durostone)		
Mineralisch-Acrylgebundene Materialien z.B. Küchenplatten/Waschbecken	Corian®, Noblan®, Hi-Macs®, Staron®, Rausolid®, Varicor®	50-70	0,02-0,04
Mineral-Acrylic bound materials e.g. Kitchen worktops/sink			



Kunststoffe

Plastics

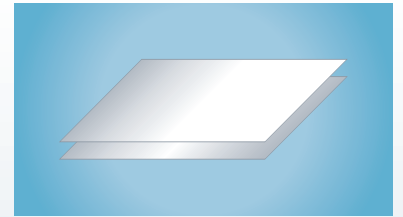

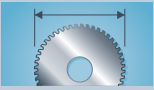
Art. Ø mm	Type	Anwendung · Application	
10.8000 Ø mm 120–300 	Kunststoff Universal	Universalblatt für das Bauhandwerk, Ladenbau, Messebau, Renovierungsarbeiten	561
	Plastic universal	Universal blade for construction, shop fitting, booth builder, renovations	
10.9000 Ø mm 350–400 	Kunststoff 7-Zahn Geometrie	Durch 7-Zahn Geometrie hervorragende Schnittgüte, exakter Schnitt und höchste Standzeit	562
	Plastic 7-tooth geometry	7-tooth geometry gives excellent cutting quality, precise cut and maximum tool life	
10.9050 Ø mm 250–350 	Acrylglas (Plexiglas) Klarsichtschnitt	Für Fertigschnitte, Klarsichtschnitte in homogene Werkstoffe, Thermoplaste wie Acrylglas (Plexiglas) PC, PMMA.	563
	Acrylic (Plexiglas) clear cut view	For finishing cut, clear cut view in homogenous material, thermoplastics such as acrylic (plexiglass), PC, PMMA.	
11.1000 Ø mm 200–600 	Fensterprofile & Kunststoffe. Positiver Spanwinkel	Für Trenn- und Gehrungsschnitte in dick- bis dünnwandigen Platten und Hohlprofilen z.B. Fensterprofile aus PVC	565
	Window profiles & plastics. Positive hook angle	For sizing cuts and mitre cuts in thin and thick-walled boards and hollow profiles, e.g. window profiles made of PVC	
11.1050 Ø mm 250–550 	Fensterprofile & Kunststoffe. Positiver Spanwinkel / Dünnschnitt	Für Trenn- und Gehrungsschnitte in dünnwandigen Platten und Hohlprofilen z.B. Fensterprofile aus PVC	567
	Window profiles & plastics. Positive hook angle / Thin-Cut	For sizing cuts and mitre cuts in thin-walled boards and hollow profiles, e.g. window profiles made of PVC	





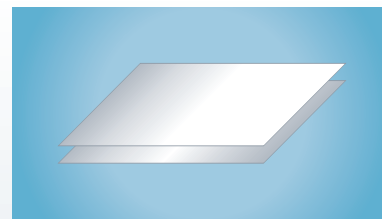

Art.
100
101
102

Kunststoffe

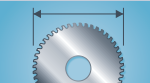
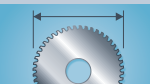
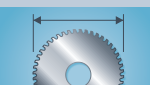
Plastics

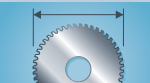

Art. Ø mm	Type	Anwendung · Application	
11.1100 Ø mm 250-600 	Fensterprofile & Kunststoffe. Negativer Spanwinkel	Für Trenn- und Gehrungsschnitte in dünn- bis mittelwandige Platten und Hohlprofile, z.B. Fensterprofile aus PCV	569
	Window profiles & plastics. Negative hook angle	For sizing cuts and mitre cuts in thin/medium-walled boards and hollow profiles, e.g. window profiles made of PVC	
11.1120 Ø mm 120-550 	Fensterprofile & Kunststoffe. Negativer Spanwinkel / Dünnschnitt	Für Trenn- und Gehrungsschnitte in dünnwandige Platten und Hohlprofile, z.B. Fensterprofile aus PCV	571
	Window profiles & plastics. Negative hook angle / Thin-Cut	For sizing cuts and mitre cuts in thin-walled boards and hollow profiles, e.g. window profiles made of PVC	
11.1320 Ø mm 120-500 	Fensterprofile mit Gummidichtung & Kunststoffe	Hervorragende Schnittqualität bei Trenn- und Gehrungsschnitten in Dünnwandige Platten und Hohlprofile, z.B. Fensterprofile speziell mit eingezogener Gummidichtung .	573
	Window profiles with rubber seal & plastics	Excellent cutting quality for sizing cuts and mitre cuts in thin-walled boards and hollow profiles, e.g. window profiles made of PVC especially with rubber seal.	
11.1350  Ø mm 160-350 	Diamant Universal	Speziell für Duroplaste wie: Glasfaserverstärkte sowie Kohlefaserverstärkte Kunststoffe (GFK, CFK), Carbon, Aramidfaserkunststoffe (AFK) HP, HPL, PUR.	575
	Diamond Universal	Excellent for Duroplastic materials such as: Glas fibre plastic (GFK), Carbon fibre plastic (CFK), Carbon, Aramid fibre plastic (AFK), HP, HPL, PUR.	
11.1370  Ø mm 250-350 	Diamant · Formatieren · Fertigschnitt · Harte Kunststoffe · Abrasive Werkstoffe	Durch DP (Polykristalliner Diamant) Bestückung ideal zum Trennen extrem abrasiver, zu hohem Schneidenverschleiß führender Materialien in Fertigschnitt Qualität.	577
	Diamond · Panel-sizing · Finishing cut · Hard plastics · Abrasive materials	Due to DP (Polychristalline Diamond) teeth excellent for cutting extreme abrasive, heavy machining and abrading materials in finishing-cut quality.	

1



2



3



4



5



6



7



8



9



10



Art.
100
101
102

Kunststoffe

Plastics

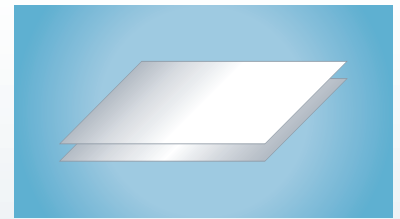

Art. Ø mm	Type	Anwendung · Application	
11.1425 Ø mm 120–500 	Kunststoffe · Profile · Furniere / Dünnschnitt	Ideal für Fertigschnitte in dünnwandige Holz- und Kunststoffteile (Leisten, Bilderrahmen) sowie Furniere und harte Thermoplaste wie PC, PMMA (Acrylglas, Plexiglas)	579
	Plastics · Profiles · Veneers / Thin-Cut	Ideal for finishing-cuts in thin-walled wood and plastic parts e.g. strips, picture frames. Excellent also for veneers and hard thermoplastics such as PC, PMMA (acrylic, plexiglas)	
11.1430 Ø mm 120–500 	Harte Kunststoffe · Abrasive Werkstoffe · Fertigschnitt/Dünnschnitt	Ideal für Fertigschnitte in dünnen Platten und Profilmaterial aus harten Kunststoffen (Thermoplaste) wie: PVC, PE, PA, ABS, POM PC, PMMA (Acrylglas) sowie generell abrasive Werkstoffe wie Faserzementplatten, Eternit, Corian, Trespa ...	581
	Hard plastics · abrasive materials · Finishing-cut / Thin-Cut	Excellent for finishing-cuts in thin-walled boards and profiles of hard plastics (thermoplastics) such as: PVC, PE, PA, ABS, POM, PC, PMMA (acrylics). In general also excellent for abrasive materials such as gypsum and cemented boards, Eternit, Corian, Trespa ...	
11.1450 Ø mm 210–600 	Kapp- und Gehrungs-Kreissägeblätter · Wechselzahn/negativ	Spezialprogramm für Kapp- und Gehrungssägen. Hohe Zähnezahl hervorragend für nahezu alle Kunststoffe und Plattenwerkstoffe/Profile furniert oder beschichtet.	583
	Chop- and mitre circular saws · alternate top bevel tooth/negative	Special selection for chop- and mitre saws. High number of teeth excellent for almost all kind of plastics and veneered/coated boards/profiles.	
11.1460 Ø mm 250–400 	Formatieren · Fertigschnitt · Harte Kunststoffe · Abrasive Werkstoffe	Zum Formatieren von Platten/Profilen in verschiedenen Dicken aus Thermoplaste wie PVC, PE, PA, ABS usw. Ebenfalls ideal bei Duroplasten und Mineralwerkstoffe wie HPL (Trespa, Resopal), Corian, Noblan und Abrasive Werkstoffe wie GFK, CFK	585
	Panel-sizing · Finishing cut · Hard plastics · Abrasive Materials	For sizing panels/profiles of thermoplastics in various thicknesses made of: PVC, PE, PA, ABS ... Also ideal for duroplastics and mineral materials such as HPL (Trespa, Resopal) Corian, Noblan and abrasive materials such as GFK, CFK.	
11.1470 Ø mm 220–400 	Formatieren · Fertigschnitt · Trapez/ Flachzahn	Zum Formatieren von Platten/Profilen in verschiedenen Dicken. Für nahezu alle Kunststoffe (Duroplasten und Thermoplasten) geeignet. Ideal auch bei beidseitig mit Kunststoff beschichtete Platten.	587
	Panel-sizing · Finishing cut · Triple chip/flat tooth	For sizing panels/profiles in various thicknesses. For almost all kinds of plastics (duro- and thermoplastics). Ideal also for double-side plastic coated boards.	



Art.
100
101
102

Kunststoff Universal
Plastic universal

Art. **10.8000**

GOLD-STAR LINE 

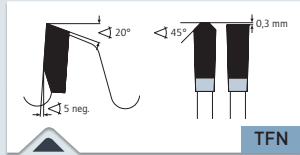
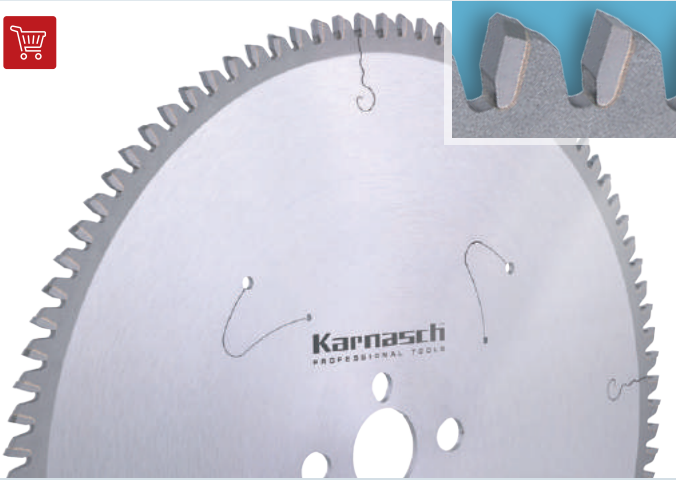







- > Trapez-Flachzahn Negativ
- > Triple-chip / flat tooth negative

MASCHINE · MACHINE

Für Elektro Handkreissägen, Tauchsägen, Kapp- und Gehrungssägen, Radialarmsägen, Tisch- und Formatkreissägen, Akkubetriebene Maschinen.

For portable circular saws, cross-cut saws, panel saws, sizing and mitre saws, table and radial arm saws, battery-driven saws.

✓ OPTIMAL · OPTIMAL ✓ GUT · GOOD ✓ MÖGLICH · POSSIBLE

✓		Kunststoffe, Plexiglas, Duro- und Thermoplaste	Plastics, plexiglass, acrylics, duro- and thermoplastics
✓		Ne-Metall wie Alu, Messing, Kupfer	Non ferrous materials like alu, copper, brass
✓		Dünobleche, Sandwich Material, Verbundstoffe	Thin iron sheets, sandwich material, composites
✓		Weichholz, Hartholz, Exotenzholz, Quer	Soft wood, hard wood, and exotic wood across the grain
✓		Holz mit Einschlüssen wie Nägel, Klammern, Beton- und Mörtelreste	Wood with inclusions like nails, clips, concrete residues
✓		Gips-Zement-Steinwollplatten, Eternit, GFK, CFK, HPL, Mineralwerkstoffe	Gypsum/Cement fibre boards, Rockwool, Eternit, GRP, CFK, HPL, Mineral material
✓		Gasbetonsteine	Autoclaved aerated concrete blocks

ANWENDUNG · APPLICATION

Das ideale Blatt für den Ladenbau, Messebau, Renovierungsarbeiten. Für eine Vielzahl von Materialien wie: Ne-Metalle, Kunststoffe, Plexiglas, Spanplatten, Thermofassadenplatten.

Weitere Alu-Negativ Blätter siehe Art. 11.1100 Seite 569 sowie Art. 11.1120 Seite 571.

The ideal blade for shop construction, trade fair construction, renovation work. For many materials such as: non-ferrous materials, plastics, plexiglas, chipboard, thermo façade plates.

Other aluminium negative sheets: see item 11.1100 page 569, and item 11.1120 page 571.

Art.							€
108000.120.010	● 120	2,8/2,0	20	34 TFN	-	-	33,65
108000.136.010	● 136	2,8/2,0	20/10	40 TFN	2-6-32	-	39,30
108000.150.010	● 150	2,8/2,0	20/16	42 TFN	2-6-32	-	40,50
108000.160.010	● 160	2,8/2,0	20/16	42 TFN	2-6-32	-	40,95
108000.165.010	● 165	2,8/2,0	20	48 TFN	2-6-32	-	44,20
108000.170.010	● 170	2,8/2,0	30	48 TFN	-	-	44,35
108000.180.010	● 180	2,8/2,0	30	48 TFN	UNI 1	-	44,90
108000.185.010	● 185	2,8/2,0	20/16	48 TFN	2-6-32	-	46,55
108000.190.010	● 190	2,8/2,0	30	54 TFN	UNI 1	-	49,55
108000.200.010	● 200	2,8/2,0	30	54 TFN	UNI 1	-	50,55
108000.210.010	● 210	2,8/2,0	30	54 TFN	UNI 1	-	51,25
108000.216.010	● 216	2,8/2,0	30	60 TFN	UNI 1	-	56,45
108000.216.020	● 216	2,8/2,0	30	80 TFN	UNI 1	-	67,75
108000.220.010	● 220	2,8/2,0	30	54 TFN	UNI 1	-	54,15
108000.230.010	● 230/235	2,8/2,0	30	64 TFN	UNI 1	-	56,75
108000.240.010	● 240	2,8/2,0	30	64 TFN	UNI 1	-	56,75
108000.250.010	● 250	3,2/2,5	30	60 TFN	UNI 1 + UNI 2	✓	70,65
108000.250.020	● 250	3,2/2,5	30	80 TFN	UNI 1 + UNI 2	✓	78,70
108000.250.030	● 250	2,8/2,2	30	100 TFN	UNI 1 + UNI 2	✓	97,35
108000.260.010	● 260	3,2/2,5	30	80 TFN	UNI 1 + UNI 2	✓	85,10
108000.270.010	● 270	3,2/2,5	30	88 TFN	UNI 1 + UNI 2	✓	86,95
108000.280.010	● 280	3,2/2,5	30	88 TFN	UNI 1 + UNI 2	✓	89,15
108000.300.010	● 300	3,2/2,5	30	72 TFN	UNI 1 + UNI 2	✓	84,55
108000.300.020	● 300	3,2/2,5	30	96 TFN	UNI 1 + UNI 2	✓	88,55
108000.300.030	● 300	2,8/2,2	30	120 TFN	UNI 1 + UNI 2	✓	115,50

UNI 1 = 2-7-42 + 2-9-46,40 UNI 2 = 2-10-60 + 2-11-63 + 2-12-64

● Gefertigt/Manufactured 232,50 mm



Video 

561

1



2



3



4



5



6



7



8



9



10

Art.
100
101
102

Karnasch® HARTMETALL-BESTÜCKTE KREISSÄGEBLÄTTER CARBIDE TIPPED CIRCULAR SAW BLADES

Art. **10.9000**

Kunststoff 7-Zahn Geometrie
Plastic 7-tooth geometry

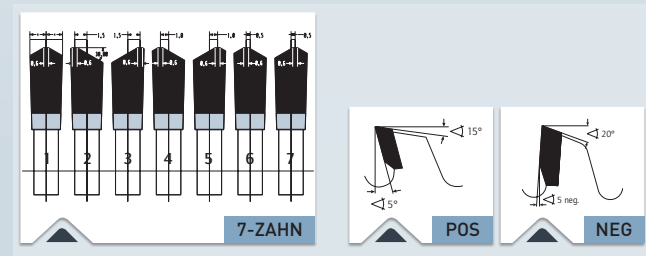

MASCHINE · MACHINE

Für Tisch- und Formatkreissägen, Kapp- und Gehrungssägen, Radialsägen, Doppelabkürzsägen.

For table and sizing circular saws, panel and mitre saws, radial arm saws, cross cut saws.

✓ OPTIMAL · OPTIMAL ✓ GUT · GOOD ✓ MÖGLICH · POSSIBLE

✓		Kunststoffe, Plexiglas, Duro- und Thermoplaste	Plastics, plexiglass, acrylics, duro- and thermoplastics
✓		Ne-Metall wie Alu, Messing, Kupfer	Non ferrous materials like alu, copper, brass
✓		Mineralische/acrylgebundene Massivplatten/Küchenplatten: Corian®, Noblan®, Hi-Macs®, Staron®, Rausolid®, Varicor®	Mineral/acrylic bound solid boards/kitchen worktops: Corian®, Noblan®, Hi-Macs®, Staron®, Rausolid®, Varicor®
✓		HPL-Duroplastische Schichtstoffplatten/Fassadenplatten: Trespa®, Resopal®, Duropal®, Formica®, Kronospan®, Decodur®	HPL High-Pressure-Laminate solid boards/façade panels: Trespa®, Resopal®, Duropal®, Formica®, Kronospan®, Decodur®

ANWENDUNG · APPLICATION

Durch 7-Zahn Geometrie hervorragende Schnittgüte, exakter Schnitt und höchste Standzeiten in sämtlichen Ne-Metallen, Acrylharzen (Plexiglas), Pertinax, Corian, Variocor, Resoplan u.ä.

Outstanding cut quality due to 7-Cut geometry, accurate cutting and the highest service life in all non-ferrous metals, acrylic resins (Plexiglas), Pertinax, Corian, Variocor, Resoplan and similar material.

Art.							€
109000.350.010	▲ 350	3,6/3,0	30	84 POS	UNI	✓	111,25
109000.400.010	▲ 400	4,0/3,2	30	70 POS	UNI	✓	124,90
109000.400.020	▲ 400	3,6/3,0	30	98 NEG	UNI	✓	146,30

UNI = 2-10-60 + 2-11-63 + 2-12-64

Weitere Abmessungen auf Anfrage. ▲ Solange Vorrat reicht.
Other dimensions are available on request ▲ While stocks last.



Video

Acrylglas (Plexiglas) Klarsichtsnitt
Acrylic (Plexiglas) clear cut view

Art. 10.9050

GOLD-STAR LINE

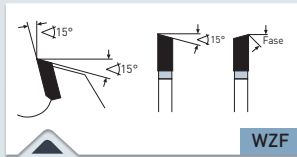
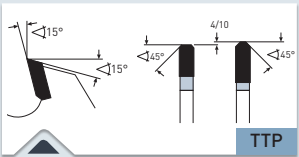
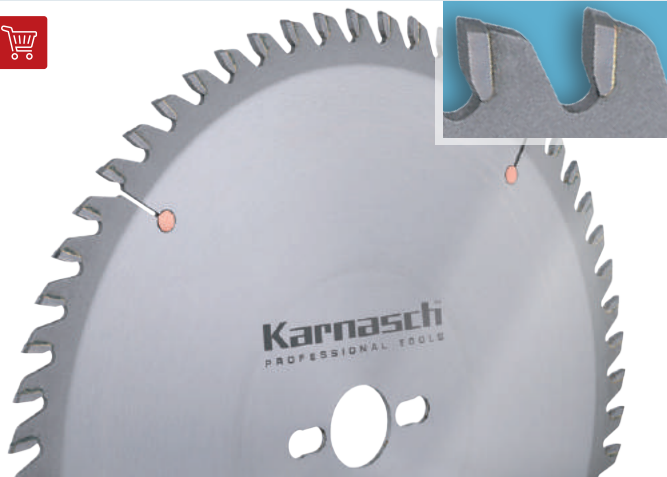

> Trapez Flach Positiv
> Triple-chip / flat tooth positive

> Wechselzahn-Fase
> Alternate top bevel+bevel

MASCHINE · MACHINE

Für Tischkreissägen, Formatsägen, Plattenaufteilsägen

For table-mounted circular saws, final trimming saws, panel sizing saws

✓ OPTIMAL · OPTIMAL ✓ GUT · GOOD ✓ MÖGLICH · POSSIBLE

✓		Kunststoffe, Plexiglas, Duro- und Thermoplaste	Plastics, plexiglass, acrylics, duro- and thermoplastics
✓		Minerale/acrylgebundene Massivplatten/Küchenplatten: Corian®, Noblan®, Hi-Macs®, Staron®, Rausolid®, Varicor®	Mineral/acrylic bound solid boards/kitchen worktops: Corian®, Noblan®, Hi-Macs®, Staron®, Rausolid®, Varicor®
✓		HPL-Duroplastische Schichtstoffplatten/Fassadenplatten: Trespa®, Resopal®, Duropal®, Formica®, Kronospan®, Decodur®	HPL High-Pressure-Laminate solid boards/façade panels: Trespa®, Resopal®, Duropal®, Formica®, Kronospan®, Decodur®

ANWENDUNG · APPLICATION

Für Fertigschnitte, Klarsichtsnitte in homogene Werkstoffe, Thermoplaste wie Acrylglas (Plexiglas) PC, PMMA.

Wenigzahn Ausführung (TTP): Thermoplast im Paketschnitt. Zugfestigkeit > 50 N/mm².

Vielzahn Ausführung (WZF): Thermoplast dünnwandig. Zugfestigkeit max. 50 N/mm².

Empfehlung: Kühlung mit Emulsion, siehe ab Seite 711.

For finishing cut, clear cut view in homogenous material, thermoplastics such as acrylic (plexiglass), PC, PMMA.

Low tooth number (TTP): Thermoplastics, for stacks of material. Tensile strength > 50 N/mm².

High tooth number (WZF): Thermoplastics, thin-walled. Tensile strength max. 50 N/mm².

Recommendation: Use emulsion as a coolant, see from page 711.

Art.						€
109050.250.010	● 250	3,2/2,2	30	48 TTP	UNI	101,10
109050.250.020	● 250	3,2/2,2	30	80 WZF	UNI	130,85
109050.300.010	● 300	3,2/2,2	30	60 TTP	UNI	155,20
109050.300.020	● 300	3,2/2,2	30	96 WZF	UNI	153,00
109050.350.010	● 350	3,5/2,5	30	72 TTP	UNI	153,00
109050.350.020	● 350	3,5/2,5	30	108 WZF	UNI	170,60

UNI = 2-10-60 + 2-9-46,4 + 2-7-42

Weitere Abmessungen auf Anfrage
Other dimensions are available on request

Bombierter Flankenstil

Bossed edge style

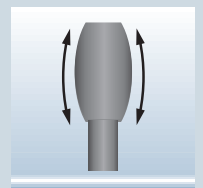

Video

563

- 1
- 2
- 3
- 4
- 5
- 6
- 7
- 8
- 9
- 10

Art. 100 101 102



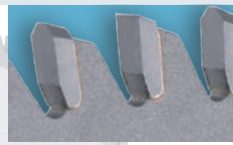

Art. **11.1000**

GOLD-STAR LINE 

Fensterprofile & Kunststoffe. Positiver Spanwinkel
Window profiles & plastics. Positive hook angle



✓ OPTIMAL · OPTIMAL ✓ GUT · GOOD ✓ MÖGLICH · POSSIBLE

✓		Kunststoffe, Plexiglas, Duro- und Thermoplaste	Plastics, plexiglass, acrylics, duro- and thermoplastics
✓		Ne-Metall wie Alu, Messing, Kupfer	Non ferrous materials like alu, copper, brass
✓		Mineralische/acrylgebundene Massivplatten/Küchenplatten: Corian®, Noblan®, Hi-Macs®, Staron®, Rausolid®, Varicor®	Mineral/acrylic bound solid boards/kitchen worktops: Corian®, Noblan®, Hi-Macs®, Staron®, Rausolid®, Varicor®
✓		HPL-Duroplastische Schichtstoffplatten/Fassadenplatten: Trespa®, Resopal®, Duropal®, Formica®, Kronospan®, Decodur®	HPL High-Pressure-Laminate solid boards/façade panels: Trespa®, Resopal®, Duropal®, Formica®, Kronospan®, Decodur®

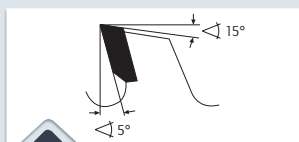

> Trapez-Flachzahn Positiv
> Triple-chip / flat tooth positive

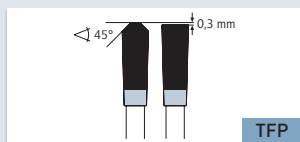

ANWENDUNG · APPLICATION

Für Trenn- und Gehrungsschnitte in dick- bis dünnwandigen Platten und (je nach Zähnezahl) Hohlprofilen z.B. Fensterprofile aus PVC, auch Glasfaserverstärkt mit und ohne Gummidichtung. (Durch positiven Schnittwinkel vorzugsweise für automatischen Vorschub. Auch manueller Vorschub möglich).

Achswinkel-Blätter für nahezu gratfreie, sauberste Schnitte und höchste Standzeiten in Fensterprofilen aus PVC (auch glasfaserverstärkt-GFK)

SPEZIELL MIT GUMMIDICHTUNG siehe Art. 11.1320, Seite 573

For sizing cuts and mitre cuts in thin and thick-walled boards and (depending on the number of teeth) hollow profiles, e.g. window profiles made of PVC, also glass fibre reinforced (GRP) with and without rubber seal. (Positive hook angle preferably for automatic feed. Manual feed also possible).

Axial-Angle blades for virtually burr-free, cleanset cuts and longest service life in window profiles made of PVC (also glass fibre reinforced-GRP)

SPECIFICALLY WITH RUBBER SEAL see Art. 11.1320, Page 573

MASCHINE · MACHINE

Tisch- und Formatkreissägen, Doppelgehrungssägen, automatische Kappkreissägen, CNC-Bearbeitungszentren.

Table and sizing saws, double mitre saws, automatic cross-cut saws, CNC machining centers.

1 

2 

3 

4 

5 

6 

7 

8 

9 







10 

Art. 100, 101, 102

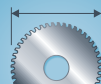
Fensterprofile & Kunststoffe. Positiver Spanwinkel
Window profiles & plastics. Positive hook angle

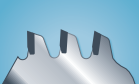
Art. 11.1000

GOLD-STAR LINE 

Art.								€
111000.200.010	• 200	3,2/2,5	30	54 TFP	UNI 1 + UNI 2	-	-	67,15
111000.200.020	• 200	2,8/2,2	30	72 TFP	UNI 1 + UNI 2	-	-	79,10
111000.225.010	• 225	2,5/1,8	30	68 TFP	UNI 1 + UNI 2	-	-	74,80
111000.250.010	• 250	3,2/2,5	30	60 TFP	UNI 1 + UNI 2	✓	-	73,85
111000.250.020	• 250	3,2/2,5	30	80 TFP	UNI 1 + UNI 2	✓	-	82,75
111000.250.030	• 250	3,2/2,5	32	80 TFP	UNI 2	✓	-	82,75
111000.275.010	• 275	3,2/2,5	40	72 TFP	2-9-55+4-12-64	✓	-	88,50
111000.280.010	• 280	3,2/2,5	30	68 TFP	UNI 1 + UNI 2	✓	-	89,30
111000.280.020	• 280	3,2/2,5	30	96 TFP	UNI 1 + UNI 2	✓	-	93,70
111000.300.010	• 300	3,2/2,5	30	72 TFP	UNI 1 + UNI 2	✓	-	89,30
111000.300.020	• 300	3,2/2,5	30	96 TFP	UNI 1 + UNI 2	✓	-	93,70
111000.300.030	• 300	3,2/2,5	32	72 TFP	UNI 2	✓	-	89,30
111000.300.040	• 300	3,2/2,5	32	96 TFP	UNI 2	✓	-	93,70
111000.300.050	• 300	3,2/2,5	40	96 TFP	2-9-55+4-12-64	✓	-	107,50
111000.320.010	• 320	3,2/2,5	30	84 TFP	UNI 1 + UNI 2	✓	-	104,50
111000.330.010	• 330	3,2/2,5	32/30	72 TFP	UNI 2	✓	-	95,55
111000.330.020	• 330	3,2/2,5	32/30	96 TFP	UNI 2	✓	-	115,85
111000.350.010	▲ 350	4,0/3,2	30	54 TFP	UNI 1 + UNI 2	✓	-	91,55
111000.350.020	• 350	3,4/2,8	30	72 TFP	UNI 1 + UNI 2	✓	-	100,80
111000.350.030	• 350	3,4/2,8	30	92 TFP	UNI 1 + UNI 2	✓	-	116,70
111000.350.040	• 350	3,4/2,8	30	108 TFP	UNI 1 + UNI 2	✓	-	129,80
111000.350.050	• 350	3,4/2,8	32	92 TFP	UNI 2	✓	-	116,70
111000.350.060	• 350	3,4/2,8	32	108 TFP	UNI 2	✓	-	123,30
111000.350.070	• 350	3,4/2,8	40	92 TFP	2-9-55+4-12-64	✓	-	116,70
111000.350.080	• 350	3,4/2,8	40	108 TFP	2-9-55+4-12-64	✓	-	129,80
111000.370.010	• 370	3,6/3,0	30	96 TFP	UNI 1 + UNI 2	✓	-	134,95
111000.400.010	• 400	3,8/3,2	30	72 TFP	UNI 1 + UNI 2	✓	✓	138,10
111000.400.020	• 400	3,8/3,2	30	96 TFP	UNI 1 + UNI 2	✓	✓	158,90
111000.400.030	• 400	3,8/3,2	30	120 TFP	UNI 1 + UNI 2	✓	✓	179,70
111000.400.040	• 400	3,8/3,2	32	96 TFP	UNI 2	✓	✓	158,90
111000.400.050	• 400	3,8/3,2	40	96 TFP	4-12-64+2-15-80	✓	✓	158,90
111000.400.060	• 400	3,8/3,2	40	120 TFP	4-12-64+2-15-80	✓	✓	179,70
111000.400.070	• 400	3,8/3,2	50	96 TFP	4-15-80	✓	✓	158,90
111000.400.080	• 400	3,8/3,2	50	120 TFP	4-15-80	✓	✓	179,70
111000.420.010	• 420	4,0/3,2	30	72 TFP		✓	✓	151,40
111000.420.020	• 420	4,0/3,2	30	96 TFP	2-9-46,4 + UNI 2	✓	✓	160,10
111000.420.030	• 420	4,0/3,2	30	120 TFP	+ 2-10,5-70	✓	✓	180,95
111000.430.010	• 430	4,0/3,2	30	96 TFP		✓	✓	167,15
111000.450.010	• 450	4,0/3,2	30	72 TFP	UNI 1 + UNI 2 + 2-10,5-70	✓	✓	154,30
111000.450.020	• 450	4,0/3,2	30	108 TFP	UNI 1 + UNI 2 + 2-10,5-70	✓	✓	170,50
111000.450.030	• 450	4,0/3,2	30	120 TFP	UNI 1 + UNI 2 + 2-10,5-70	✓	✓	185,75
111000.450.040	• 450	4,0/3,2	32	96 TFP	UNI 2	✓	✓	161,65
111000.450.050	• 450	4,0/3,2	32	120 TFP	UNI 2	✓	✓	185,75
111000.500.010	• 500	4,2/3,6	30	72 TFP		✓	✓	163,15
111000.500.020	• 500	4,2/3,6	30	96 TFP	2-9-46,4 + UNI 2	✓	✓	183,30
111000.500.030	• 500	4,2/3,6	30	120 TFP	+ 2-10,5-70	✓	✓	206,65
111000.500.040	• 500	4,2/3,6	30	144 TFP		✓	✓	232,65
111000.500.050	• 500	4,2/3,6	32	120 TFP	UNI 2	✓	✓	206,65
111000.500.060	• 500	4,2/3,6	32	144 TFP	UNI 2	✓	✓	232,65
111000.550.010	• 550	4,4/3,8	30	72 TFP		✓	✓	254,00
111000.550.020	• 550	4,4/3,8	30	110 TFP	2-9-46,4 + UNI 2	✓	✓	282,40
111000.550.030	• 550	4,4/3,8	30	144 TFP	+ 2-10,5-70	✓	✓	336,75
111000.550.040	• 550	4,4/3,8	32	96 TFP	UNI 2	✓	✓	262,50
111000.550.050	• 550	4,4/3,8	32	128 TFP	UNI 2	✓	✓	297,90
111000.550.060	• 550	4,4/3,8	80	128 TFP	6-9-100	✓	✓	304,05
111000.600.010	• 600	4,6/4,0	30	140 TFP	UNI 1 + UNI 2	✓	✓	378,25

▲ = Auslaufartikel / Discontinued

UNI 1 = 2-7-42+2-9-46,4 UNI 2 = 2-10-60+2-11-63+2-12-64

Weitere Alu-Positiv-Blätter S. 567 · More Alu-Positive blades page 567



Video



565

- 1 
- 2 
- 3 
- 4 
- 5 
- 6 
- 7 
- 8 
- 9 
- 10 

Art.
100
101
102

Art. **11.1050**



Fensterprofile & Kunststoffe. Positiver Spanwinkel / Dünnschnitt
Window profiles & plastics. Positive hook angle / Thin-Cut



✓ OPTIMAL · OPTIMAL ✓ GUT · GOOD ✓ MÖGLICH · POSSIBLE

✓		Kunststoffe, Plexiglas, Duro- und Thermoplaste	Plastics, plexiglass, acrylics, duro- and thermoplastics
✓		Ne-Metall wie Alu, Messing, Kupfer	Non ferrous materials like alu, copper, brass
✓		Mineralische/acrylgebundene Massivplatten/Küchenplatten: Corian®, Noblan®, Hi-Macs®, Staron®, Rausolid®, Varicor®	Mineral/acrylic bound solid boards/kitchen worktops: Corian®, Noblan®, Hi-Macs®, Staron®, Rausolid®, Varicor®
✓		HPL-Duroplastische Schichtstoffplatten/Fassadenplatten: Trespa®, Resopal®, Duropal®, Formica®, Kronospan®, Decodur®	HPL High-Pressure-Laminate solid boards/façade panels: Trespa®, Resopal®, Duropal®, Formica®, Kronospan®, Decodur®

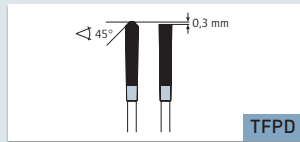
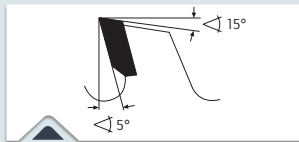

TFPD

- > Trapez-Flachzahn Positiv dünn
- > Triple-chip / flat tooth thin positive

MASCHINE · MACHINE

Tisch- und Formatkreissägen, Doppelgehrungssägen, automatische Kappkreissägen, CNC-Bearbeitungszentren, akkubetriebene Sägemaschinen.

Table and sizing saws, double mitre saws, automatic cross-cut saws, CNC machining centers, battery-Driven saws.

ANWENDUNG · APPLICATION

Für Trenn- und Gehrungsschnitte in dünnwandigen Platten und Hohlprofilen z.B. Fensterprofile aus PVC, auch Glasfaserverstärkt mit und ohne Gummidichtung. (Durch positiven Schnittwinkel vorzugsweise für automatischen Vorschub. Auch manueller Vorschub möglich).

Durch dünne Schnittbreite wenig Kraftaufwand und Verschnitt. Daher ideal auch für akkubetriebenen Maschinen.

Achswinkel-Blätter für nahezu gratfreie, sauberste Schnitte und höchste Standzeiten in Fensterprofilen aus PVC (auch glasfaserverstärkt-GFK)

SPEZIELL MIT GUMMIDICHTUNG siehe Art. 11.1320, Seite 573

For sizing cuts and mitre cuts in thin-walled boards and hollow profiles, e.g. window profiles made of PVC, also glass fibre reinforced (GRP) with and without rubber seal. (Positive hook angle preferably for automatic feed. Manual feed also possible).

Due to the small cutting width less cutting pressure and waste. Therefore ideal also for battery-powered machines.

Axial-Angle blades for virtually burr-free, cleanset cuts and longest service life in window profiles made of PVC (also glass fibre reinforced-GRP)

SPECIFICALLY WITH RUBBER SEAL see Art. 11.1320, Page 573

- 1
- 2
- 3
- 4
- 5
- 6
- 7
- 8
- 9
- 10







Art. 100
101
102

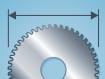

Fensterprofile & Kunststoffe. Positiver Spanwinkel / Dünnschnitt
Window profiles & plastics. Positive hook angle / Thin-Cut

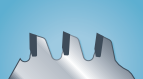
Art. **11.1050**

GOLD-STAR LINE 

Art.								€
111050.250.010	• 250	2,4/1,8	30	100 TFPD	UNI 1 + UNI 2	✓	-	97,40
111050.300.010	• 300	2,4/1,8	30	120 TFPD	UNI 1 + UNI 2	✓	-	115,50
111050.350.010	• 350	2,7/2,0	30	120 TFPD	UNI 1 + UNI 2	✓	-	136,80
111050.400.010	• 400	3,1/2,5	30	128 TFPD	UNI 1 + UNI 2	✓	✓	153,40
111050.420.010	• 420	3,4/2,8	30	132 TFPD	2-9-46,4 + UNI 2 + 2-10,5-70	✓	✓	175,90
111050.450.010	• 450	3,4/2,8	30	138 TFPN	2-9-46,4 + UNI 2 + 2-10,5-70	✓	✓	182,60
111050.500.010	• 500	3,4/2,8	30	144 TFPN	2-9-46,4 + UNI 2 + 2-10,5-70	✓	✓	202,05
111050.550.010	• 550	3,6/3,0	30	160 TFPN	2-9-46,4 + UNI 2 + 2-10,5-70	✓	✓	278,90

UNI 1 = 2-7-42 + 2-9-46,40 UNI 2 = 2-10-60 + 2-11-63 + 2-12-64

Dünnschnitt für höchste Schnittgüte mit wenig Schnittdruck und Materialverbrauch

Verwenden Sie daher bei der Bearbeitung von Kunststoffen, wertvollen Hölzern sowie NE-Metalle wie Alu, Kupfer und Messing Dünnschnitt-Kreissägen Art. 11.1120 Seite 571, 11.1150 Seite 671, 11.1050 Seite 567, 11.1425 Seite 663, und 11.1430 Seite 631.

Thin-cut blades for highest cutting quality with little cutting pressure and a minimum of material waste

Thin-cut blades are therefore perfect for cutting plastics, precious wood and non ferrous metals such as aluminum, copper and brass. See Art. 11.1120 page 571, 11.1150 page 671, 11.1050 page 567, 11.1425 page 663 and 11.1430 page 631



POWER.
PRECISION.
PERFORMANCE.

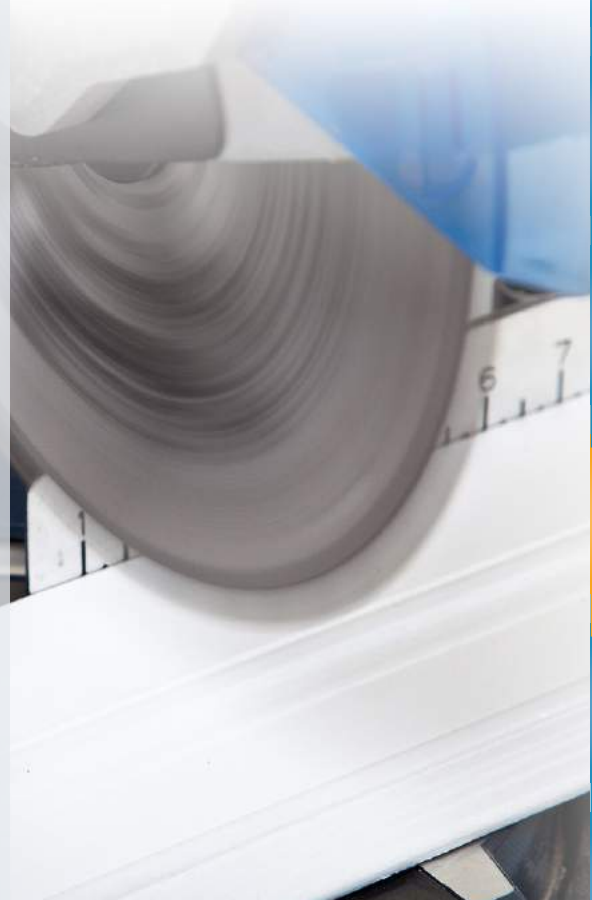

Karnasch®
PROFESSIONAL TOOLS

- 1 
- 2 
- 3 
- 4 
- 5 
- 6 
- 7 
- 8 
- 9 
- 10 

Art.
100
101
102



Art. **11.1100**

Fensterprofile & Kunststoffe. Negativer Spanwinkel
Window profiles & plastics. Negative hook angle

GOLD-STAR LINE 



✓ OPTIMAL · OPTIMAL ✓ GUT · GOOD ✓ MÖGLICH · POSSIBLE

✓		Kunststoffe, Plexiglas, Duro- und Thermoplaste	Plastics, plexiglass, acrylics, duro- and thermoplastics
✓		Ne-Metall wie Alu, Messing, Kupfer	Non ferrous materials like alu, copper, brass

ANWENDUNG · APPLICATION

Für Trenn- und Gehrungsschnitte in dünn- bis mittelwandige Hohlprofile, z.B. Fensterprofile aus PCV, auch Glasfaserverstärkt mit und ohne Gummidichtung. (Durch negativen Spanwinkel vorzugsweise für manuellen Vorschub. Auch automatischer Vorschub möglich).

Achswinkel-Blätter für nahezu gratfreie, sauberste Schnitte und höchste Standzeiten in Fensterprofile aus PVC (auch glasfaserverstärkt-GFK)

SPEZIELL MIT GUMMIDICHTUNG siehe Art 11.1320, Seite 573

For sizing cuts and mitre cuts in thin/medium-walled hollow profiles, e.g. window profiles made of PVC, also glass fibre reinforced (GRP) with and without rubber seal. (Negative hook angle preferably for manual feed. Automatic feed also possible).

Axial-Angle blades for virtually burr-free, cleanest cuts and longest service life in window profiles made of PVC (also glass fiber reinforced-GRP)

SPECIFICALLY WITH RUBBER SEAL see Art. 11.1320, Page 573

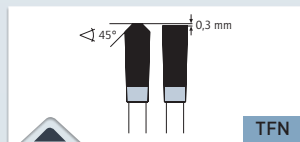
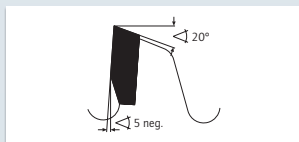

- > Trapez-Flachzahn Negativ
- > Triple-chip / flat tooth negative

MASCHINE · MACHINE

Kappkreissägen, Gehrungs- und Doppelgehrungssägen, CNC-Bearbeitungszentren, Radialarmsägen, Tisch- und Formatkreissägen, Abläng- und Kappsägen.

Automatic cross-cut saws, Mitre and double mitre saws, CNC-machining centers, Table and sizing saws, Panel saws, Radial arm saws



Art. 100, 101, 102









Video 

Fensterprofile & Kunststoffe. Negativer Spanwinkel
Window profiles & plastics. Negative hook angle

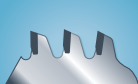
Art. 11.1100

GOLD-STAR LINE 

Art.								€
111100.250.010	● 250	3,2/2,5	30	60 TFN	UNI 1 + UNI 2	✓	-	73,85
111100.250.020	● 250	3,2/2,5	30	80 TFN	UNI 1 + UNI 2	✓	-	82,75
111100.250.030	● 250	2,8/2,2	30	80 TFN	UNI 1 + UNI 2	✓	-	73,75
111100.250.040	● 250	2,8/2,2	30	100 TFN	UNI 1 + UNI 2	✓	-	88,65
111100.250.050	● 250	3,2/2,5	32	60 TFN	UNI 2	✓	-	73,85
111100.250.060	● 250	3,2/2,5	32	80 TFN	UNI 2	✓	-	82,75
111100.250.070	● 250	3,2/2,5	32	100 TFN	UNI 2	✓	-	110,25
111100.275.010	● 275	3,2/2,5	40	88 TFN	2-9-55+4-12-64	✓	-	100,95
111100.275.020	● 275	3,2/2,5	40	110 TFN	2-9-55+4-12-64	✓	-	126,90
111100.280.010	● 280	3,2/2,5	30	88 TFN	UNI 1 + UNI 2	✓	-	100,95
111100.300.010	● 300	3,2/2,5	30	72 TFN	UNI 1 + UNI 2	✓	-	89,30
111100.300.020	● 300	3,2/2,5	30	96 TFN	UNI 1 + UNI 2	✓	-	93,70
111100.300.030	● 300	2,8/2,2	30	120 TFN	UNI 1 + UNI 2	✓	-	123,65
111100.300.040	● 300	3,2/2,5	32	72 TFN	UNI 2	✓	-	89,30
111100.300.050	● 300	3,2/2,5	32	96 TFN	UNI 2	✓	-	100,15
111100.300.060	● 300	2,8/2,2	32	120 TFN	UNI 2	✓	-	123,65
111100.300.070	● 300	3,2/2,5	40	72 TFN	2-9-55+4-12-64	✓	-	89,30
111100.300.080	● 300	3,2/2,5	40	96 TFN	2-9-55+4-12-64	✓	-	107,50
111100.305.010	● 305	3,2/2,5	30	96 TFN	UNI 1 + UNI 2	✓	-	108,55
111100.330.010	● 330	3,2/2,5	30	72 TFN	UNI 1 + UNI 2	✓	-	99,05
111100.330.020	● 330	3,2/2,5	30	96 TFN	UNI 1 + UNI 2	✓	-	113,40
111100.330.030	● 330	2,8/2,2	30	120 TFN	UNI 1 + UNI 2	✓	-	133,60
111100.330.040	● 330	3,2/2,5	32	72 TFN	UNI 2	✓	-	99,05
111100.330.050	● 330	3,2/2,5	32	96 TFN	UNI 2	✓	-	113,40
111100.330.060	● 330	2,8/2,2	32	120 TFN	UNI 2	✓	-	133,60
111100.350.010	● 350	3,4/2,8	30	90 TFN	UNI 1 + UNI 2	✓	-	115,20
111100.350.020	● 350	3,4/2,8	30	108 TFN	UNI 1 + UNI 2	✓	-	123,30
111100.350.030	● 350	3,2/2,5	30	140 TFN	UNI 1 + UNI 2	✓	-	148,40
111100.350.040	● 350	3,4/2,8	32	90 TFN	UNI 2	✓	-	116,00
111100.350.050	● 350	3,4/2,8	32	108 TFN	UNI 2	✓	-	129,80
111100.350.060	● 350	3,4/2,8	40	84 TFN	2-9-55+4-12-64	✓	-	109,90
111100.350.070	● 350	3,4/2,8	40	108 TFN	2-9-55+4-12-64	✓	-	129,80
111100.350.080	● 350	3,4/2,8	50	84 TFN	4-15-80	✓	-	109,90
111100.350.090	● 350	3,4/2,8	50	108 TFN	4-15-80	✓	-	127,55
111100.370.010	● 370	3,6/3,0	30	90 TFN	UNI 1 + UNI 2	✓	-	137,55
111100.370.020	● 370	3,6/3,0	30	108 TFN	UNI 1 + UNI 2	✓	-	149,25
111100.380.010	● 380	3,8/3,2	32	90 TFN	UNI 2	✓	-	137,55
111100.380.020	● 380	3,8/3,2	32	110 TFN	UNI 2	✓	-	149,25
111100.380.030	● 380	3,8/3,2	32	132 TFN	UNI 2	✓	-	181,65
111100.400.010	● 400	3,8/3,2	30	96 TFN	UNI 1 + UNI 2	✓	✓	158,90
111100.400.020	● 400	3,8/3,2	30	108 TFN	UNI 1 + UNI 2	✓	✓	172,10
111100.400.030	● 400	3,8/3,2	30	120 TFN	UNI 1 + UNI 2	✓	✓	179,70
111100.400.040	● 400	3,8/3,2	32	96 TFN	UNI 2	✓	✓	158,90
111100.400.050	● 400	3,8/3,2	32	108 TFN	UNI 2	✓	✓	172,10
111100.400.060	● 400	3,8/3,2	32	120 TFN	UNI 2	✓	✓	179,70
111100.400.070	● 400	3,8/3,2	40	96 TFN	4-12-64+2-15-80	✓	✓	158,90
111100.400.080	● 400	3,8/3,2	40	120 TFN	4-12-64+2-15-80	✓	✓	179,70
111100.400.090	● 400	3,8/3,2	50	96 TFN	4-15-80	✓	✓	179,70
111100.400.100	● 400	3,8/3,2	50	120 TFN	4-15-80	✓	✓	181,40
111100.420.010	● 420	4,0/3,2	30	96 TFN		✓	✓	160,10
111100.420.020	● 420	4,0/3,2	30	108 TFN	2-9-46,4 + UNI 2 + 2-10,5-70	✓	✓	170,50
111100.420.030	● 420	4,0/3,2	30	120 TFN		✓	✓	180,95
111100.420.040	● 420	4,0/3,2	40	96 TFN	4-12-64+2-15-80	✓	✓	160,10
111100.420.050	● 420	4,0/3,2	40	108 TFN	4-12-64+2-15-80	✓	✓	170,50
111100.420.060	● 420	4,0/3,2	40	120 TFN	4-12-64+2-15-80	✓	✓	180,95
111100.450.010	● 450	4,0/3,2	30	108 TFN		✓	✓	180,95
111100.450.020	● 450	4,0/3,2	30	128 TFN	2-9-46,4 + UNI 2 + 2-10,5-70	✓	✓	189,40
111100.500.010	● 500	4,2/3,6	30	120 TFN	2-9-46,4 + UNI 2 + 2-10,5-70	✓	✓	206,65
111100.500.020	● 500	4,2/3,6	30	140 TFN	2-9-46,4 + UNI 2 + 2-10,5-70	✓	✓	226,20
111100.520.010	● 520	4,2/3,6	30	120 TFN	-	✓	✓	276,80
111100.550.010	● 550	4,4/3,8	30	108 TFN		✓	✓	268,75
111100.550.020	● 550	4,4/3,8	30	132 TFN	2-9-46,4 + UNI 2 + 2-10,5-70	✓	✓	301,00
111100.600.010	● 600	4,6/4,0	30	140 TFN	UNI 1 + UNI 2	✓	✓	378,25

UNI 1 = 2-7-42 + 2-9-46,40 UNI 2 = 2-10-60 + 2-11-63 + 2-12-64

Weitere Aluminium Negativ-Blätter siehe S. 561/571 · More Aluminium Negativ blades see page 561/571



Art.
100
101
102

Art. **11.1120**



Fensterprofile & Kunststoffe. Negativer Spanwinkel / Dünnschnitt
Window profiles & plastics. Negative hook angle / Thin-Cut

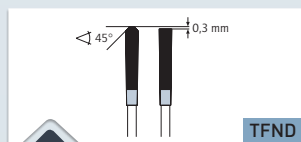
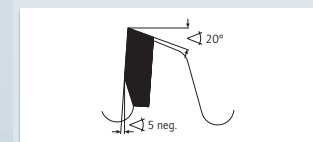

- > Trapez-Flachzahn Negativ Dünn
- > Triple-chip / flat tooth negative thin-cut

MASCHINE · MACHINE

Kappkreissägen, Gehrungs- und Doppelgehrungssägen, CNC-Bearbeitungszentren, Radialarmsägen, Tisch- und Formatkreissägen, Abläng- und Kappsägen, Handkreissägen, Tauchsägen, akkubetriebene Maschinen.

Automatic cross-cut saws, Mitre and double mitre saws, CNC-machining centers, Table and sizing saws, Panel saws, Radial arm saws, Portable machines, Battery-driven saws.

✓ OPTIMAL · OPTIMAL ✓ GUT · GOOD ✓ MÖGLICH · POSSIBLE

✓		Kunststoffe, Plexiglas, Duro- und Thermoplaste	Plastics, plexiglass, acrylics, duro- and thermoplastics
✓		Ne-Metall wie Alu, Messing, Kupfer	Non ferrous materials like alu, copper, brass

ANWENDUNG · APPLICATION

Für Trenn- und Gehrungsschnitte in dünnwandige Platten und Hohlprofile, z.B. Fensterprofile aus PCV, auch Glasfaserverstärkt mit und ohne Gummidichtung. [Durch negativen Spanwinkel vorzugsweise für manuellen Vorschub. Auch automatischer Vorschub möglich].

Durch dünne Schnittbreite wenig Kraftaufwand und Verschnitt. Daher auch ideal für Akku-Maschinen.

Achswinkel-Blätter für nahezu gratfreie, sauberste Schnitte und höchste Standzeiten in Fensterprofile aus PVC (auch glasfaserverstärkt-GFK)

SPEZIELL MIT GUMMIDICHTUNG siehe Art 11.1320, Seite 573

For sizing cuts and mitre cuts in thin-walled boards and hollow profiles, e.g. window profiles made of PVC, also glass fibre reinforced (GRP) with and without rubber seal. (Negative hook angle preferably for manual feed. Automatic feed also possible).

Due to the small cutting width less cutting pressure and waste. Therefore ideal also for Battery-Powered machines.

Axial-Angle blades for virtually burr-free, cleanest cuts and longest service life in window profiles made of PVC (also glass fiber reinforced-GRP)

SPECIFICALLY WITH RUBBER SEAL see Art. 11.1320, Page 573

1

2

3

4

5

6

7

8

9

10

Art. 100, 101, 102



Fensterprofile & Kunststoffe. Negativer Spanwinkel / Dünnschnitt
Window profiles & plastics. Negative hook angle / Thin-Cut

Art. 11.1120



Art.									€
111120.120.010	• 120	2,2/1,6	20	36 TFND	-	-	-	-	38,15
111120.136.010	• 136	2,2/1,6	20/10	40 TFND	2-6-32	-	-	-	39,20
111120.150.010	• 150	2,4/1,6	20/16	42 TFND	2-6-32	-	-	-	39,65
111120.160.010	• 160	2,4/1,8	20/16	42 TFND	2-6-32	-	-	-	40,95
111120.160.020	• 160	2,2/1,6	20/16	60 TFND	2-6-32	-	-	-	54,45
111120.160.030	• 160	2,4/1,8	30	42 TFND	UNI 1	-	-	-	40,20
111120.170.010	• 170	2,4/1,8	30	48 TFND	UNI 1	-	-	-	44,60
111120.180.010	• 180	2,4/1,8	30	48 TFND	UNI 1	-	-	-	44,60
111120.180.020	• 180	2,2/1,6	30	64 TFND	UNI 1	-	-	-	58,10
111120.185.010	• 185	2,2/1,6	20/16	64 TFND	2-6-32	✓	-	-	58,90
111120.190.010	• 190	2,4/1,8	30	54 TFND	UNI 1	-	-	-	48,95
111120.190.020	• 190	2,2/1,6	30	68 TFND	UNI 1	-	-	-	61,80
-	• 200	2,2/1,8	20	100 TFND	Siehe/See Art. 11.1150, Seite/Page 671			-	-
111120.200.010	• 200	2,4/1,8	30	54 TFND	UNI 1	-	-	-	49,45
111120.200.020	• 200	2,2/1,6	30	68 TFND	UNI 1	✓	-	-	62,65
-	• 200	2,2/1,8	30	100 TFND	Siehe/See Art. 11.1150, Seite/Page 671			-	-
-	• 200	2,2/1,8	32	100 TFND	Siehe/See Art. 11.1150, Seite/Page 671			-	-
111120.210.010	• 210	2,4/1,8	30	54 TFND	UNI 1	-	-	-	50,05
111120.210.020	• 210	2,2/1,6	30	72 TFND	UNI 1	-	-	-	66,65
111120.216.010	• 216	2,4/1,8	30	60 TFND	UNI 1	-	-	-	55,15
111120.216.020	• 216	2,2/1,6	30	80 TFND	UNI 1	-	-	-	73,60
111120.220.010	• 220	2,4/1,8	30	64 TFND	UNI 1	-	-	-	56,80
111120.220.020	• 220	2,2/1,6	30	80 TFND	UNI 1	-	-	-	73,60
111120.225.010	• 225	2,4/1,8	30	64 TFND	UNI 1	-	-	-	56,80
111120.225.020	• 225	2,2/1,6	30	80 TFND	UNI 1	-	-	-	73,60
111120.230.010	• 230/235	2,4/1,8	30	64 TFND	UNI 1	-	-	-	56,80
111120.230.020	• 230/235	2,2/1,6	30	80 TFND	UNI 1	-	-	-	73,60
111120.240.010	• 240	2,2/1,8	30	80 TFND	UNI 1	-	-	-	73,60
111120.250.010	• 250	2,8/2,2	30	80 TFND	UNI 1 + UNI 2	✓	-	-	73,75
111120.250.020	• 250	2,2/1,8	30	100 TFND	UNI 1 + UNI 2	✓	-	-	97,40
111120.250.030	• 250	2,2/1,8	32/30	120 TFND	UNI 2	✓	-	-	134,10
111120.260.010	• 260	2,4/1,8	30	68 TFND	UNI 1 + UNI 2	✓	-	-	74,35
111120.260.020	• 260	2,4/1,8	30	100 TFND	UNI 1 + UNI 2	✓	-	-	105,35
111120.270.010	• 270	2,4/1,8	30	80 TFND	UNI 1 + UNI 2	✓	-	-	79,55
111120.270.020	• 270	2,4/1,8	30	100 TFND	UNI 1 + UNI 2	✓	-	-	107,60
111120.300.010	• 300	2,4/1,8	30	120 TFND	UNI 1 + UNI 2	✓	-	-	115,50
111120.305.010	• 305	2,6/2,0	30	80 TFND	UNI 1 + UNI 2	✓	-	-	88,65
111120.305.020	• 305	2,4/1,8	30	120 TFND	UNI 1 + UNI 2	✓	-	-	115,50
111120.330.010	• 330	2,4/1,8	30	96 TFND	UNI 1 + UNI 2	✓	-	-	122,65
111120.330.020	• 330	2,4/1,8	30	120 TFND	UNI 1 + UNI 2	✓	-	-	131,25
111120.330.030	• 330	2,4/1,8	32	96 TFND	UNI 2	✓	-	-	122,65
111120.330.040	• 330	2,4/1,8	32	120 TFND	UNI 2	✓	-	-	131,25
111120.350.010	• 350	2,7/2,0	30	120 TFND	UNI 1 + UNI 2	✓	-	-	136,80
111120.400.010	• 400	3,1/2,5	30	130 TFND	UNI 1 + UNI 2	✓	✓	-	153,40
111120.420.010	• 420	3,4/2,8	30	132 TFND	2-9-46,4 + UNI 2 + 2-10,5-70	✓	✓	-	175,90
111120.450.010	• 450	3,4/2,8	30	138 TFND	2-9-46,4 + UNI 2 + 2-10,5-70	✓	✓	-	182,60
111120.500.010	• 500	3,4/2,8	30	144 TFND	2-9-46,4 + UNI 2 + 2-10,5-70	✓	✓	-	202,05
111120.550.010	• 550	3,6/3,0	30	160 TFND	2-9-46,4 + UNI 2 + 2-10,5-70	✓	✓	-	278,90

• Gefertigt/Manufactured 232,50 mm

UNI 1 = 2-7-42 + 2-9-46,40 UNI 2 = 2-10-60 + 2-11-63 + 2-12-64



Art.
100
101
102

Art. **11.1320**

Fensterprofile mit Gummidichtung & Kunststoffe
Window profiles with rubber seal & plastics

GOLD-STAR LINE

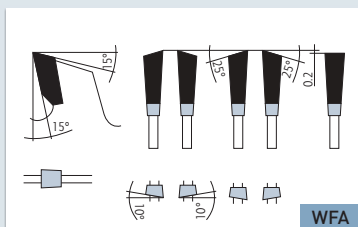
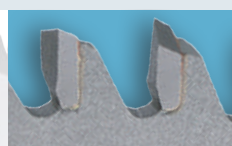

> Wechselzahn/Flachzahn mit Achswinkel
> Alternate top bevel / flat tooth with axial angle

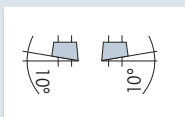

MASCHINE · MACHINE

Plattenaufteilsägen vertikal, Formatkreissägen, Doppelgehrungssägen, BAZ mit Sägeaggregat, mechanische Kappsägemaschinen, Unterflur-kappsägemaschinen, CNC-Bearbeitungszentren.

Vertical panel sizing saws, trimming saws, double mitre saws, mechanical chop saws, under frame mounted chop saws, machining centers with saw aggregate.

✓ OPTIMAL · OPTIMAL ✓ GUT · GOOD ✓ MÖGLICH · POSSIBLE

✓		Kunststoffe, Plexiglas, Duro- und Thermoplaste	Plastics, plexiglass, acrylics, duro- and thermoplastics
✓		Furniere	Veneers
✓		Profileleisten	Profiled wood
✓		Spanplatten, Hartfaserplatten, Platten ohne Belag LDF, MDF, HDF	Chipboard, hard fibre board, boards without laminate LDF, MDF, HDF
✓		Weichholz, Hartholz, Exotenholz, Quer	Soft wood, hard wood, and exotic wood across the grain
✓		Leimholz, Tischler- und Furnier-sperrholz, Schichtholzplatten	Bonded wood, blockboard and veneer plywood, laminated wood
✓		Spanplatten, Hartfaserplatten Kunststoff beschichtet/furniert, MDF, HDF	Chipboard, hard fibre board, plastic-coated/veneered, MDF, HDF
✓		Mineralische/acrylgebundene Massivplatten/Küchenplatten: Corian®, Noblan®, Hi-Macs®, Staron®, Rausolid®, Varicor®	Mineral/acrylic bound solid boards/kitchen worktops: Corian®, Noblan®, Hi-Macs®, Staron®, Rausolid®, Varicor®
✓		HPL-Duroplastische Schichtstoff-platten/Fassadenplatten: Trespa®, Resopal®, Duropal®, Formica®, Kronospan®, Decodur®	HPL High-Pressure-Laminate solid boards/face panels: Trespa®, Resopal®, Duropal®, Formica®, Kronospan®, Decodur®

ANWENDUNG · APPLICATION

Für **hervorragende, ausrissfreie Schnittqualität** bei Trenn- und Gehrungsschnitte in dünnwandige Hohlprofile und Platten aus Kunststoff, z.B. Fensterprofile aus PVC (Polyvinylchlorid). Durch die aggressive Spezialgeometrie werden selbst die eingezogenen Gummidichtungen bei Fensterprofilen **ohne auszufransen** sauber durchtrennt.

Hervorragende und ausrissfreie Schnittqualität ebenfalls bei Kunststoffummantelte oder furnierte Leisten und Türzagen, Folien aus PVC auf Rollen, bedruckte Dekorpaneele, Dekor Finish Folien, Holzwerkstoffe auch mit dicken Deckschichten, Massivholz quer. Auch gute Ergebnisse beim Sägen von Kunststoffen mit hohen Glasfaser/Kohlefaseranteile (GFK/CFK)

Hervorragende Ergebnisse auch bei Fensterprofilen aus Faserverbundstoffe. Z.B. von Firma REHAU Geneo-Fenster aus RAU-RIBRO®

Excellent, splinter-free finishing-cut quality. For sizing and mitre cuts in thin-walled hollow profiles and boards of plastic, e.g. window profiles of PVC (Polyvinyl Chloride). Due to the aggressive cutting geometry even the rubber seals in window profiles will be **cut without fraying**.

Excellent and splinter-free finishing-cut quality also in plastic profiles/door frames veneered of foil-sheathed, sizing films on rolls of PVC, printed decorative (AC) paper, decor finish films, wooden based materials including material with very thick top layers and solid wood across the grain. Also good cutting results in glass fibre and carbon fibre reinforced plastics (GRP, CFK)

Excellent results in window profiles made of fiber composites. For example from company REHAU Geneo-windows made of RAU-FIBRO®



Video



Fensterprofile mit Gummidichtung & Kunststoffe
Window profiles with rubber seal & plastics

Art. **11.1320**

GOLD-STAR LINE 

Art.							€
111320.200.010	• 200	3,0/2,2	30	60 WFA	2-6,2-42 + 4-6-52 + 4-6,6-60	-	122,65
111320.220.010	• 220	3,0/2,2	30	70 WFA	UNI	-	130,65
111320.250.010	• 250	3,0/2,2	30	80 WFA	UNI	✓	141,40
111320.303.010	• 303	3,0/2,2	30	100 WFA	UNI	✓	171,45
111320.350.010	• 350	3,0/2,2	30	100 WFA	UNI	✓	188,75
111320.400.010	• 400	3,0/2,2	30	120 WFA	UNI	✓	229,60
111320.450.010	• 450	3,6/2,8	30	130 WFA	UNI	✓	256,55
111320.500.010	• 500	3,6/2,8	30	140 WFA	UNI	✓	284,35

UNI = 2-7-42 + 2-9-46,40 + 2-10-60

Kunststoffe, Massivholz und Gummidichtungen ausrissfrei Sägen.

(Siehe Art. 11.1320)

Splinter and fraying free cutting in plastics, solid wood and window rubber seals.

(See Art. 11.1320)



POWER.
PRECISION.
PERFORMANCE.

Art. **11.1320**



Karnasch®
PROFESSIONAL TOOLS



Art.
100
101
102

Art. **11.1350**

Diamant Universal
Diamond Universal

GOLD-STAR LINE 

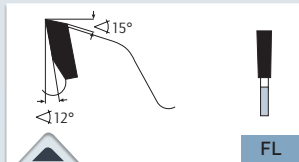







> Flachzahn
> Flat tooth

MASCHINE · MACHINE

Für Handkreissägen, Tauchsägen, Kapp- und Gehrungssägen, Tisch- und Formatkreissägen

For hand-held circular saws, mitre saws, cross-cut saws, table and sizing saws

✓ OPTIMAL · OPTIMAL ✓ GUT · GOOD ✓ MÖGLICH · POSSIBLE

✓		Kunststoffe, Plexiglas, Duro- und Thermoplaste	Plastics, plexiglass, acrylics, duro- and thermoplastics
✓		HPL-Duroplastische Schichtstoffplatten/Fassadenplatten: Trespa®, Resopal®, Duropal®, Kronospan®, Decodur®	HPL High-Pressure-Laminate solid boards/façade panels: Trespa®, Resopal®, Duropal®, Formica®, Kronospan®, Decodur®
✓		Gips-Zement-Steinwollplatten, Eternit, GFK, CFK, HPL, Mineralwerkstoffe	Gypsum/Cement fibre boards, Rockwool, Eternit, GRP, CFK, HPL, Mineral material
✓		Gasbetonsteine	Autoclaved aerated concrete blocks
✓		Mineralische/acrylgebundene Massivplatten/Küchenplatten: Corian®, Noblan®, Hi-Macs®, Staron®, Rausolid®, Varicor®	Mineral/acrylic bound solid boards/kitchen worktops: Corian®, Noblan®, Hi-Macs®, Staron®, Rausolid®, Varicor®
✓		Spanplatten, Hartfaserplatten, Platten ohne Belag LDF, MDF, HDF	Chipboard, hard fibre board, boards without laminate LDF, MDF, HDF
✓		Spanplatten, Hartfaserplatten Kunststoff beschichtet/furniert, MDF, HDF	Chipboard, hard fibre board, plastic-coated/veneered, MDF, HDF

ANWENDUNG · APPLICATION

Durch DP (Polykristalliner Diamant) Zähne ideal für Zuschnitte sowie Formatschnitte in extrem abrasive, zu hohen Schneidenverschleiß führenden Materialien wie: Corian, Trespa, Laminat, MDF, Gips- und Zementgebundene Platten (Faserzement), Steinwollplatten, Heraklith, Eternit.

Blätter mit niedriger Zahnzahl wie: 160mm mit 4 Zähnen, 190mm mit 6 Zähnen, 230mm mit 6 Zähnen, 250mm mit 6 Zähnen und 300mm mit 8 Zähnen, sind speziell geeignet für Gips- und Zementgebundene Platten. (Faserzement)

Speziell hervorragend ebenfalls für Duroplaste wie: Glasfaserverstärkte sowie Kohlefaserverstärkte Kunststoffe (GFK, CFK), Carbon, Aramidfaserkunststoffe (AFK) HP, HPL, PUR.

Niedere Zahnreihe für Zuschnitte, höhere Zahnreihe für Formatschnitte. Achtung: Keine Fertigschnitt-Blatt (DP-Bestückung = 4mm). Fertigschnitt-Blätter siehe Art. 11.1370 Seite 576

Due to DP (Polycrystalline Diamond) teeth excellent for sizing, formatting, cross cuts in extreme abrasive, heavy machining and abrading materials such as: Corian, Trespa, laminates, MDF, gypsum and cement-bonded boards (fiber cement), Rockwool boards, Heraklith products, Eternit.

Circular saws with the lowest number of teeth as: 160mm with 4 teeth, 190mm with 6 teeth, 230mm with 6 teeth, 250mm with 6 teeth and 300mm with 8 teeth, are specially designed for gypsum and cement-bonded panels (fiber cement).

Also excellent for Duroplastic materials such as: Glas fibre plastic (GFK), Carbon fibre plastic (CFK), Carbon, Aramid fibre plastic (AFK), HP, HPL, PUR.





Lower tooth row for sizing, higher tooth row for format cuts. Attention: no finishing cut blade (DP-Tip height = 4mm). Finishing cut-blades see Art. 11.3070 page 576



Video

- 1 
- 2 
- 3 
- 4 
- 5 
- 6 
- 7 
- 8 
- 9 
- 10 

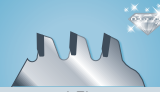
Art.
100
101
102

Art.							€
111350.160.005	● 160	2,2/1,6	20/16	4 FL	2-6-32,5	✓	39,70
111350.160.010	● 160	2,2/1,6	20/16	8 FL	2-6-32,5	✓	78,05
111350.160.020	● 160	2,2/1,6	20/16	30 FL	2-6-32,5	✓	231,50
111350.180.010	● 180	2,2/1,6	30/20	8 FL	2-7-42	✓	78,55
111350.190.005	● 190	2,2/1,6	30/20	6 FL	2-7-42	✓	54,90
111350.190.010	● 190	2,2/1,6	30/20	8 FL	2-7-42	✓	79,10
111350.190.020	● 190	2,2/1,6	30/20	30 FL	2-7-42	✓	249,60
111350.210.010	● 210	2,2/1,6	30	12 FL	UNI	✓	111,10
111350.210.020	● 210	2,2/1,6	30	30 FL	UNI	✓	279,05
111350.216.010	● 216	2,2/1,6	30	12 FL	UNI	✓	111,10
111350.216.020	● 216	2,2/1,6	30	30 FL	UNI	✓	279,05
111350.230.005	● 230	2,4/1,8	30	6 FL	UNI	✓	64,35
111350.230.010	● 230	2,4/1,8	30	15 FL	UNI	✓	148,30
111350.230.020	● 230	2,4/1,8	30	30 FL	UNI	✓	279,05
111350.250.005	● 250	2,4/1,8	30	6 FL	UNI	✓	65,90
111350.250.010	● 250	2,4/1,8	30	16 FL	UNI	✓	164,85
111350.250.020	● 250	2,4/1,8	30	40 FL	UNI	✓	375,65
111350.300.005	● 300	2,2/1,6	30	8 FL	UNI	✓	88,20
111350.300.010	▲ 300	2,2/1,6	30	30 FL	UNI	✓	315,00
111350.300.020	● 300	2,6/2,0	30	36 FL	UNI	✓	360,15
111350.300.030	● 300	2,6/2,0	30	48 FL	UNI	✓	468,15
111350.300.040	● 300	2,6/2,0	30	60 FL	UNI	✓	609,20
111350.350.010	● 350	2,8/2,2	30	60 FL	UNI	✓	649,50

▲ = Auslaufartikel / Discontinued · UNI = 2-7-42 + 2-9-46,40 + 2-10-60

Einblicke in die Karnasch High-Tech Produktion.

Insights into the Karnasch high-tech production.

POWER.
PRECISION.
PERFORMANCE.

NC-Löten
NC soldering



NC-Schleifen
NC grinding



Karnasch® DP-BESTÜCKTE KREISSÄGEBLÄTTER DP TIPPED CIRCULAR SAW BLADES





Art. **11.1370**

GOLD-STAR LINE 

Diamant · Formatieren · Fertigschnitt · Harte Kunststoffe · Abrasive Werkstoffe
Diamond · Panel-sizing · Finishing cut · Hard plastics · Abrasive Materials



✓ OPTIMAL · OPTIMAL ✓ GUT · GOOD ✓ MÖGLICH · POSSIBLE

✓		Kunststoffe, Plexiglas, Duro- und Thermoplaste	Plastics, plexiglass, acrylics, duro- and thermoplastics
✓		Spanplatten, Hartfaserplatten Kunststoff beschichtet/furniert, MDF, HDF	Chipboard, hard fibre board, plastic-coated/veneered, MDF, HDF
✓		Mineralische/acrylgebundene Massivplatten/Küchenplatten: Corian®, Noblan®, Hi-Macs®, Staron®, Rausolid®, Varicor®	Mineral/acrylic bound solid boards/kitchen worktops: Corian®, Noblan®, Hi-Macs®, Staron®, Rausolid®, Varicor®
✓		HPL-Duroplastische Schichtstoff- platten/Fassadenplatten: Trespa®, Resopal®, Duropal®, Formica®, Kronospan®, Decodur®	HPL High-Pressure-Laminate solid boards/façade panels: Trespa®, Resopal®, Duropal®, Formica®, Kronospan®, Decodur®
✓		Gips-Zement-Steinwollplatten, Eternit, GFK, CFK, HPL, Mineral- werkstoffe	Gypsum/Cement fibre boards, Rockwool, Eternit, GRP, CFK, HPL, Mineral material

ANWENDUNG · APPLICATION

Durch DP (Polykristalliner Diamant) Zähne extrem lange Standzeiten gegenüber Hartmetall-bestückte Kreissägeblätter. Ideal für Zuschnitte sowie Formatschnitte in extrem abrasive, zu hohen Schneidenschleiß führenden Materialien wie: Corian, Trespa, Laminat, MDF, Gips- und Zementgebundene Platten, Steinwollplatten, Heraklith, Eternit.

Speziell hervorragend ebenfalls für Duroplaste wie: Glasfaserverstärkte sowie Kohlefaserverstärkte Kunststoffe (GFK, CFK), Carbon, Aramidfaserkunststoffe (AFK) HP, HPL, PUR.

Weiterhin hervorragend für Fertigschnitte in thermoplastische Vollplatten (Acrylglas, PMMA, Polyäthylen, Polyamid usw.) sowie duroplastische Vollplatten (Schichtstoffe, HPL, Hartpapier, Trespa, Resopal, Multiplex). Weiterhin für Polymergebundene Kunststoffe, Mineralwerkstoffe wie Corian, Noblan, Hi-Macs, Staron, Rausolid usw.

Hervorragend ebenfalls für Fertigschnitte in beidseitig Kunststoffbeschichteten Plattenwerkstoffe, vorzugsweise in Verbindung mit Vorritzer. Ideal auch zum schneiden von Kunststoff-Profilen.

Due to DP (Polycrystalline Diamond) teeth extremely long tool life compared to carbide tipped circular saws. Excellent for sizing, formatting, cross cuts in extreme abrasive, heavy machining and abrading materials such as: Corian, Trespa, laminates, MDF, gypsum and cement-bonded boards, Rockwool boards, Heraklith products, Eternit.

Also excellent for Duroplastic materials such as: Glas fibre plastic (GFK), Carbon fibre plastic (CFK), Carbon, Aramid fibre plastic (AFK), HP, HPL, PUR.

For finishing cuts in solid thermoplastic boards (PMMA, acrylic glass, polyethylene, polyamide etc.) and solid duroplastic boards (HPL-high-pressure-laminate, HP-Hardpaper, phenolic resin bonded paper, phenolic laminated cotton sheets, Trespa, Resopal, Multiplex). Also for polymerbound plastics, mineral materials such as Corian, Noblan, Hi-Macs, Staron, Rausolid etc.

Excellent also for finishing cuts in double-side plastic coated boards, preferably in combination with coring sawblades. Ideal also for cutting plastic profiles.

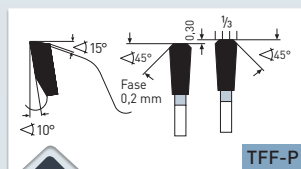

TFF-P

- > Trapez-Flachzahn (mit beidseitiger Schutzfase)
- > Triple-chip/flat tooth (with protective chamfer on both sides)

MASCHINE · MACHINE

Für Formatkreissägen, Plattensägen, Tischkreissägen

For sizing saws, panel saws, bench saws







- 1 
- 2 
- 3 
- 4 
- 5 
- 6 
- 7 
- 8 
- 9 
- 10 



Diamant · Formatieren · Fertigschnitt · Harte Kunststoffe · Abrasive Werkstoffe
Diamond · Panel-sizing · Finishing cut · Hard plastics · Abrasive Materials

Art. **11.1370**

GOLD-STAR LINE 

Art.							DP-Bestückungshöhe DP-Tip hight	€
111370.250.010	● 250	3,2/2,2	30	60 TFF-P	UNI	✓	5 mm	886,65
111370.250.020	● 250	3,2/2,2	30	80 TFF-P	UNI	✓	5 mm	1162,55
111370.300.010	● 300	3,2/2,2	30	72 TFF-P	UNI	✓	5 mm	1278,80
111370.300.020	● 300	3,2/2,2	30	96 TFF-P	UNI	✓	4 mm	1384,20
111370.303.010	● 303	3,2/2,2	30	60 TFF-P	UNI	✓	5 mm	934,70
111370.303.020	● 303	3,2/2,2	30	72 TFF-P	UNI	✓	5 mm	1278,80
111370.303.030	● 303	3,2/2,2	30	96 TFF-P	UNI	✓	4 mm	1384,20
111370.350.010	● 350	3,2/2,2	30	84 TFF-P	UNI	✓	5 mm	1333,05
111370.350.020	● 350	3,2/2,2	30	108 TFF-P	UNI	✓	4 mm	1520,60

UNI = 2-7-42 + 2-9-46,40 + 2-10-60

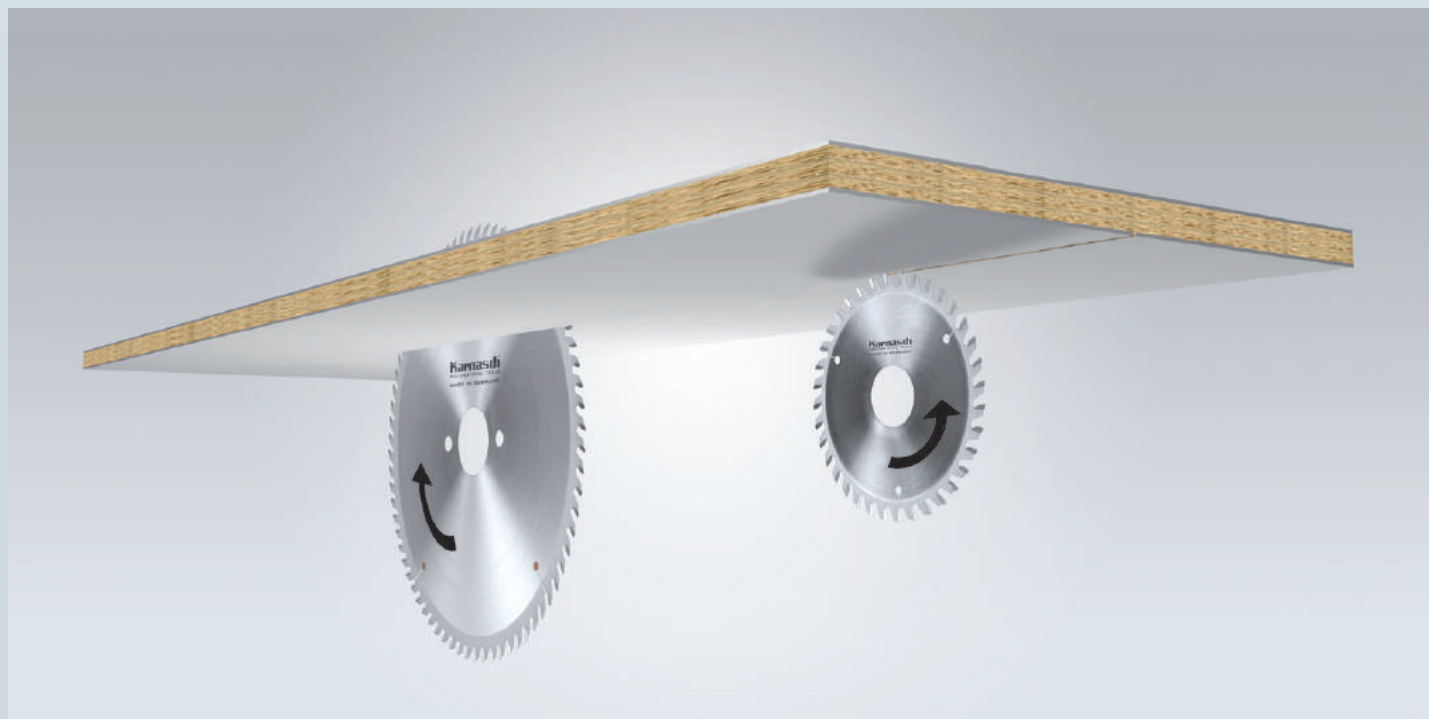

Bei Kunststoff/Melamin beschichtete Plattenwerkstoffe Vorritzen empfohlen. Ritzer siehe Seite 615/669. Sägen von beschichteten/furnierten Plattenwerkstoffe ohne Vorritzer siehe Seite 573, 637, 639, 641, 643, 645

For plastic coated/melamine boards scoring recommended. Scorer see page 615/669. Cutting of coated/veneered boards without scorer see page 573, 637, 639, 641, 643, 645

1



2



3



4



5



6



7



8



9



10



Art.
100
101
102

Art. **11.1425**

Kunststoffe · Profile · Furniere / Dünnschnitt
Plastics · Profiles · Veneers / Thin-Cut

GOLD-STAR LINE 

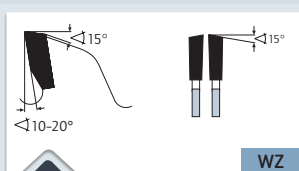









> Wechselzahn
> Alternative top bevel

MASCHINE · MACHINE

Für Handkreissägen, Tauchsägen, Tisch- und Formatkreissägen, Plattenaufteilsägen, Kappsägen, Akkusägen

For portable circular saws, table-and sizing saws, panel sizing saws, cross-cut saws, cordless saws.

✓ OPTIMAL · OPTIMAL ✓ GUT · GOOD ✓ MÖGLICH · POSSIBLE

✓		Kunststoffe, Plexiglas, Duro- und Thermoplaste	Plastics, plexiglass, acrylics, duro- and thermoplastics
✓		Furniere	Veneers
✓		Profileleisten	Profiled wood
✓		Spanplatten, Hartfaserplatten, Platten ohne Belag LDF, MDF, HDF	Chipboard, hard fibre board, boards without laminate LDF, MDF, HDF
✓		Weichholz, Hartholz, Exotenholz, Quer	Soft wood, hard wood, and exotic wood across the grain
✓		Spanplatten, Hartfaserplatten Kunststoff beschichtet/furniert, MDF, HDF	Chipboard, hard fibre board, plastic-coated/veneered, MDF, HDF
✓		Leimholz, Tischler- und Furniersperrholz, Schichtholzplatten	Bonded wood, blockboard and veneer plywood, laminated wood
✓		Mineralische/acrylgebundene Massivplatten/Küchenplatten: Corian®, Noblan®, Hi-Macs®, Staron®, Rausolid®, Varicor®	Mineral/acrylic bound solid boards/kitchen worktops: Corian®, Noblan®, Hi-Macs®, Staron®, Rausolid®, Varicor®
✓		HPL-Duroplastische Schichtstoffplatten/Fassadenplatten: Trespa®, Resopal®, Duropal®, Kronospan®, Decodur®	HPL High-Pressure-Laminate solid boards/façade panels: Trespa®, Resopal®, Duropal®, Formica®, Kronospan®, Decodur®

ANWENDUNG · APPLICATION

Durch dünne Schnittbreite ideal auch für Akkumaschinen und für teure Edelhölzer, Furniere und Leisten da wenig Verschnitt und Schnittdruck/Akkuverbrauch.

Niedere Zähnezahl: Grobe bis mittlere Schnittqualität in alle Holzwerkstoffe, Edelhölzer und Massivholz längs- und quer, Plattenwerkstoffe einseitig furniert oder Kunststoff beschichtet, Hartgewebe, Hartpapier, dickere Kunststoffprofile und Platten (Thermoplaste) Hoher Vorschub möglich.

Mittlere Zähnezahl: Gute Schnittqualität in alle Holzwerkstoffe, Edelhölzer, Massivholz und Leisten längs- und quer, Plattenwerkstoffe einseitig/zweiseitig furniert oder Kunststoff beschichtet, Hartgewebe, Hartpapier, Furnier und Furnierpakete sowie Kunststoffprofile und Platten (Thermoplaste, Duroplaste).

Hohe Zähnezahl: Sehr gute Schnittqualität in alle Holzwerkstoffe, Edelhölzer, Massivholz und Leisten vorzugsweise Querschnitte. Plattenwerkstoffe zweiseitig furniert oder Kunststoff beschichtet, Hartgewebe, Hartpapier, Furnier und Furnierpakete sowie Kunststoffprofile und Platten (Thermoplaste, Duroplaste).

Durch spezielles Hartmetall sehr gut zum Sägen harter Thermoplaste wie z.B. dünne Platten, Hohlkammerplatten aus PC (Polycarbonat), PMMA (Acrylglas-Plexiglas) Siehe hierzu auch Artikel 11.1430 Seite 581

Due to Thin-Cut also ideal for battery machines and for cutting expensive precious wood, veneer, strips because of less waste/battery consumption.

Low number of teeth: Coarse to medium cutting quality in all wooden materials, precious wood and solid wood across and along the grain, panel and boards one-side plastic coated/veneered, paper-based laminate, thicker plastic profiles and plates (Thermoplastics). High feed rate possible

Medium number of teeth: Good cutting quality in all wooden materials, precious wood, solid wood and strips across and along the grain, panel and boards one-side/two side plastic coated/veneered, paper-based laminate, veneer and veneer packages, plastic profiles/plates (Thermoplastics, Duroplastics)

High number of teeth: Very good cutting quality in all wooden materials, precious wood, solid wood and strips preferably across the grain, panel and boards two side plastic coated/veneered, paper-based laminate, veneer and veneer packages, plastic profiles/plates (Thermoplastics, Duroplastics)

Due to special carbide also excellent for cutting hard thermoplastics such as thin panels, hollow section boards Made of PC (Polycarbonate), PMMA (Acrylic-glass/Plexiglass). See here also article 11.1430, page 581



Video



1



2



3



4



5



6



7



8









9

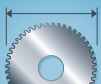

10

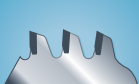

Art.
100
101
102

Art.								€
111425.120.010	● 120	1,8/1,2	20	12 WZ	20	-	-	24,10
111425.120.020	● 120	1,8/1,2	20	28 WZ	15	-	-	31,90
111425.120.030	● 120	1,8/1,2	20	44 WZ	10	-	-	41,30
111425.136.010	● 136	1,8/1,2	20/10	14 WZ	20	-	-	25,05
111425.136.020	● 136	1,8/1,2	20/10	30 WZ	15	-	-	32,15
111425.136.030	● 136	1,8/1,2	20/10	48 WZ	10	-	-	45,35
111425.160.010	● 160	1,8/1,2	20/16	16 WZ	20	2-6-32	-	24,80
111425.160.020	● 160	1,8/1,2	20/16	32 WZ	15	2-6-32	-	34,20
111425.160.030	● 160	1,8/1,2	20/16	54 WZ	10	2-6-32	-	46,35
111425.160.040	● 160	1,8/1,2	20/16	68 WZ	10	2-6-32	-	55,80
111425.165.010	● 165	1,8/1,2	20	16 WZ	20	2-6-32	-	25,05
111425.165.020	● 165	1,8/1,2	20	32 WZ	15	2-6-32	-	34,55
111425.165.030	● 165	1,8/1,2	20	54 WZ	10	2-6-32	-	46,80
111425.165.040	● 165	1,8/1,2	20	68 WZ	10	2-6-32	-	55,80
111425.180.010	● 180	1,8/1,2	20/16	18 WZ	20	2-6-32	-	25,45
111425.180.020	● 180	1,8/1,2	20/16	40 WZ	15	2-6-32	-	38,85
111425.180.030	● 180	1,8/1,2	20/16	60 WZ	10	2-6-32	-	53,10
111425.180.040	● 180	1,8/1,2	20/16	76 WZ	10	2-6-32	-	68,25
111425.190.010	● 190	1,8/1,2	30/20	18 WZ	20	2-7-42	-	27,40
111425.190.020	● 190	1,8/1,2	30/20	42 WZ	15	2-7-42	-	42,90
111425.190.030	● 190	1,8/1,2	30/20	60 WZ	10	2-7-42	-	53,70
111425.190.040	● 190	1,8/1,2	30/20	76 WZ	10	2-7-42	-	68,95
111425.200.010	● 200	2,0/1,4	30	18 WZ	20	2-7-42	-	29,00
111425.200.020	● 200	2,0/1,4	30	42 WZ	15	2-7-42	-	43,45
111425.200.030	● 200	2,0/1,4	30	64 WZ	10	2-7-42	-	54,80
111425.200.040	● 200	2,0/1,4	30	80 WZ	10	2-7-42	-	70,85
111425.210.010	● 210	2,0/1,4	30	20 WZ	20	2-7-42	-	30,50
111425.210.020	● 210	2,0/1,4	30	48 WZ	15	2-7-42	-	44,25
111425.210.030	● 210	2,0/1,4	30	64 WZ	10	2-7-42	-	55,65
111425.210.040	● 210	2,0/1,4	30	80 WZ	10	-	-	71,90
111425.216.010	● 216	2,0/1,4	30	20 WZ	20	2-7-42	-	31,50
111425.216.020	● 216	2,0/1,4	30	48 WZ	15	2-7-42	-	45,05
111425.216.030	● 216	2,0/1,4	30	64 WZ	10	2-7-42	-	56,50
111425.216.040	● 216	2,0/1,4	30	80 WZ	10	2-7-42	-	72,70
111425.220.010	● 220	2,0/1,4	30	48 WZ	20	2-7-42	-	45,05
111425.225.010	● 225	2,0/1,4	30	24 WZ	20	2-7-42	-	31,65
111425.225.020	● 225	2,0/1,4	30	48 WZ	15	2-7-42	-	45,90
111425.225.030	● 225	2,0/1,4	30	68 WZ	10	2-7-42	-	61,40
111425.225.040	● 225	2,0/1,4	30	88 WZ	10	2-7-42	-	79,60
111425.230.010	● 230/235 ●	2,0/1,4	30	24 WZ	20	2-7-42	-	32,45
111425.230.020	● 230/235 ●	2,0/1,4	30	48 WZ	15	2-7-42	-	46,60
111425.230.030	● 230/235 ●	2,0/1,4	30	68 WZ	10	2-7-42	-	62,15
111425.230.040	● 230/235 ●	2,0/1,4	30	88 WZ	10	2-7-42	-	80,35
111425.250.010	● 250	2,2/1,6	30	30 WZ	20	UNI	✓	45,90
111425.250.020	● 250	2,2/1,6	30	56 WZ	15	UNI	✓	65,85
111425.250.030	● 250	2,2/1,6	30	80 WZ	10	UNI	✓	73,55
111425.250.040	● 250	2,2/1,6	30	100 WZ	10	UNI	✓	88,15
111425.260.010	● 260	2,2/1,6	30	30 WZ	20	UNI	✓	47,35
111425.260.020	● 260	2,2/1,6	30	56 WZ	15	UNI	✓	67,20
111425.260.030	● 260	2,2/1,6	30	80 WZ	10	UNI	✓	74,55
111425.270.010	● 270	2,2/1,6	30	30 WZ	20	UNI	✓	47,60
111425.270.020	● 270	2,2/1,6	30	56 WZ	15	UNI	✓	67,45
111425.270.030	● 270	2,2/1,6	30	80 WZ	10	UNI	✓	76,50
111425.300.010	● 300	2,2/1,6	30	36 WZ	20	UNI	✓	56,10
111425.300.020	● 300	2,2/1,6	30	60 WZ	15	UNI	✓	74,05
111425.300.030	● 300	2,2/1,6	30	96 WZ	10	UNI	✓	89,15
111425.300.040	● 300	2,2/1,6	30	120 WZ	10	UNI	✓	108,90
111425.350.010	● 350	2,4/1,8	30	42 WZ	20	UNI	✓	68,70
111425.350.020	● 350	2,4/1,8	30	72 WZ	15	UNI	✓	91,05
111425.350.030	● 350	2,4/1,8	30	108 WZ	10	UNI	✓	103,80
111425.350.040	● 350	2,4/1,8	30	140 WZ	10	UNI	✓	150,55
111425.400.010	● 400	2,8/2,2	30	60 WZ	15	UNI	✓	107,25
111425.400.020	● 400	2,8/2,2	30	96 WZ	10	UNI	✓	142,95
111425.400.030	● 400	2,8/2,2	30	120 WZ	10	UNI	✓	166,80
111425.450.010	● 450	3,1/2,5	30	66 WZ	15	UNI	✓	124,55
111425.450.020	● 450	3,1/2,5	30	108 WZ	10	UNI	✓	160,75
111425.450.030	● 450	3,1/2,5	30	130 WZ	10	UNI	✓	186,05
111425.500.010	● 500	3,4/2,8	30	72 WZ	15	UNI+2-10-80	✓	161,05
111425.500.020	● 500	3,4/2,8	30	120 WZ	10	UNI+2-10-80	✓	213,35
111425.500.030	● 500	3,4/2,8	30	144 WZ	10	UNI+2-10-80	✓	240,15

● Gefertigt/Manufactured 232,50 mm · UNI = 2-7-42 + 2-9-46,40 + 2-10-60



Art.
100
101
102

Karnasch® HARTMETALL-BESTÜCKTE KREISSÄGEBLÄTTER CARBIDE TIPPED CIRCULAR SAW BLADES

Art. **11.1430**

GOLD-STAR LINE 

Harte Kunststoffe · Abrasive Werkstoffe · Fertigschnitt/Dünnschnitt
Hard plastics · Abrasive materials · Finishing-cut / Thin-cut



✓ OPTIMAL · OPTIMAL ✓ GUT · GOOD ✓ MÖGLICH · POSSIBLE

✓		Kunststoffe, Plexiglas, Duro- und Thermoplaste	Plastics, plexiglass, acrylics, duro- and thermoplastics
✓		Mineralische/acrylgebundene Massivplatten/Küchenplatten: Corian®, Noblan®, Hi-Macs®, Staron®, Rausolid®, Varicor®	Mineral/acrylic bound solid boards/kitchen worktops: Corian®, Noblan®, Hi-Macs®, Staron®, Rausolid®, Varicor®
✓		HPL-Duroplastische Schichtstoffplatten/Fassadenplatten: Trespa®, Resopal®, Duropal®, Formica®, Kronospan®, Decodur®	HPL High-Pressure-Laminate solid boards/façade panels: Trespa®, Resopal®, Duropal®, Formica®, Kronospan®, Decodur®
✓		Gips-Zement-Steinwollplatten, Eternit, GFK, CFK, HPL, Mineralwerkstoffe	Gypsum/Cement fibre boards, Rockwool, Eternit, GRP, CFK, HPL, Mineral material
✓		Dünnbleche, Sandwich Material, Verbundstoffe	Thin iron sheets, sandwich material, composites
✓		Dünne Profile aus Ne-Metall wie Alu, Messing, Kupfer	Thin profiles made of non ferrous materials like alu, copper, brass

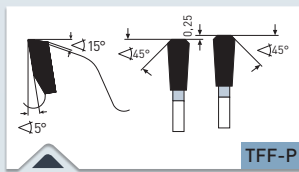

> Trapez Flach Fase Positiv
> Triple-chip/triple-chip teeth

MASCHINE · MACHINE

Für Handkreissägen, Tauchsägen, Tisch- und Formatkreissägen, Plattenaufteilsägen, Kappsägen, Akkusägen

For portable circular saws, bench- and sizing saws, panel sizing saws, cross-cut saws, cordless saws.

ANWENDUNG · APPLICATION

Durch spezielles Hartmetall/Zahnform ideal für Fertigschnitte in dünnen Platten und Profilmaterial aus harten Kunststoffen (Thermoplaste) wie: PVC, PE, PA, ABS, PS, POM PC, PMMA (Acrylglas). z.B. Hohlkammerplatten aus PMMA (Acrylglas).

Ebenfalls gut bei abrasiven, zu hohen Schneidenverschleiß führenden Materialien wie: GFK, CFK, Zementplatten, Gipsfaserplatten, Eternit.

Ebenfalls exzellent geeignet für Sandwichmaterialien mit dünnen Deckschichten. Maximale Deckschichtdicke Nicht-Eisen Metalle / Kunststoffe = 1,0 mm
Maximale Deckschichtdicke Eisenblech = 0,3 mm
Hervorragend auch für dünne Profile bis 1 mm Wandstärke aus Nicht-Eisen-Metalle, wie Alu, Kupfer, Messing.

Durch dünne Schnittbreite wenig Kraftaufwand und Verschnitt. Daher auch ideal für Akku-Maschinen.

Due to special carbide / tooth geometry excellent for finishing cuts in thin plates and profiles made of hard plastics (thermoplastics) such as: PVC, PE, PA, ABS, PS, POM PC, PMMA e.g. hollow section boards of PMMA (acrylic glass).

Also good for abrasive, heavy machining and abrading materials such as: GFK, CFK, fibre cement panels, gypsum, fibre boards, eternit.

Also excellent for sandwich materials with thin layers. Maximum layer thickness for non-ferrous-metals / plastics = 1,0 mm
Maximum layer thickness iron sheet metal = 0,3 mm
Excellent also for thin profiles up to 1 mm thickness made of non-ferrous metal such as aluminum, copper, brass.

Due to thin cutting width little cutting pressure and waste of material. Therefore also ideal for cordless machines.



Video

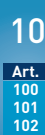





Art.
100
101
102

Harte Kunststoffe · Abrasive Werkstoffe · Fertigschnitt/Dünnschnitt
Hard plastics · Abrasive materials · Finishing-cut / Thin-cut

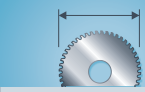
Art. **11.1430**

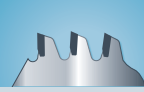
GOLD-STAR LINE 

Art.							€
111430.120.010	• 120	1,8/1,2	20	40 TFF-P	-	-	39,20
111430.160.010	• 160	1,8/1,2	20/16	56 TFF-P	2-6-32	-	47,60
111430.180.010	• 180	1,8/1,2	20/16	60 TFF-P	2-6-32	-	53,10
111430.190.010	• 190	1,8/1,2	30/20	60 TFF-P	2-7-42	-	53,70
111430.200.010	• 200	2,0/1,4	30	64 TFF-P	2-7-42	-	54,80
111430.210.010	• 210	2,0/1,4	30	64 TFF-P	2-7-42	-	55,65
111430.225.010	• 225	2,0/1,4	30	68 TFF-P	2-7-42	-	61,40
111430.230.010	• 230/235	2,0/1,4	30	68 TFF-P	2-7-42	-	62,15
111430.250.010	• 250	2,4/1,8	30	80 TFF-P	UNI	✓	73,55
111430.300.010	• 300	2,4/1,8	30	96 TFF-P	UNI	✓	89,15
111430.350.010	• 350	2,4/1,8	30	108 TFF-P	UNI	✓	103,80
111430.400.010	• 400	3,2/2,5	30	120 TFF-P	UNI	✓	123,25
111430.450.010	• 450	3,5/2,8	30	132 TFF-P	UNI	✓	190,35
111430.500.010	• 500	3,5/2,8	30	144 TFF-P	UNI	✓	245,75

• Gefertigt/Manufactured 232,50 mm · UNI = 2-7-42 + 2-9-46,40 + 2-10-60

Einblicke in die Karnasch High-Tech Produktion.

Insights into the Karnasch high-tech production.

POWER.
PRECISION.
PERFORMANCE.

100 % Kontrolle
100 % monitoring

Rauheitsmessung

Roughness measurement

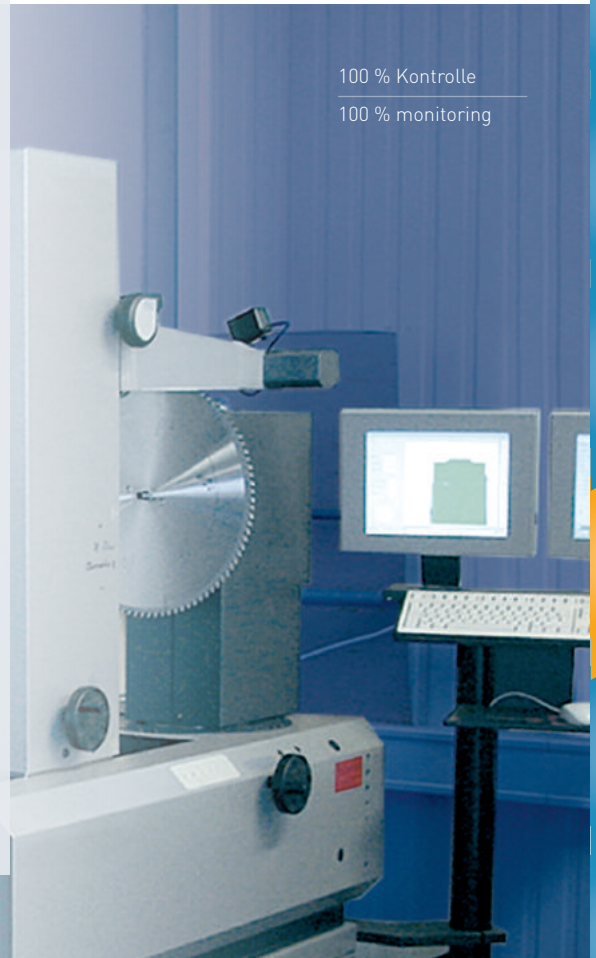
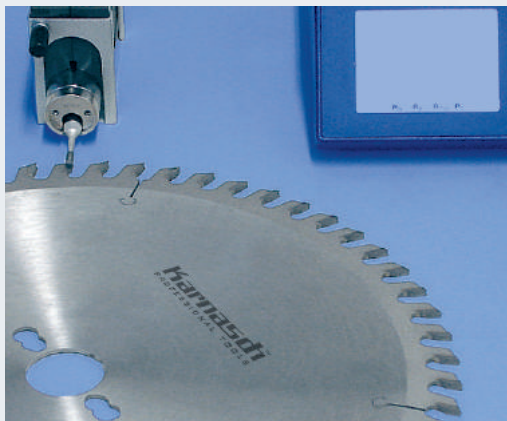

Karnasch®
PROFESSIONAL TOOLS

1



2



3



4



5



6



7



8



9



10



Art.
100
101
102

Karnasch® HARTMETALL-BESTÜCKTE KREISSÄGEBLÄTTER CARBIDE TIPPED CIRCULAR SAW BLADES

Art. **11.1450**

GOLD-STAR LINE 

Kapp- und Gehrungskreissägeblätter Wechselzahn/negativ
Chop- and mitre circular saws alternate top bevel tooth/negative

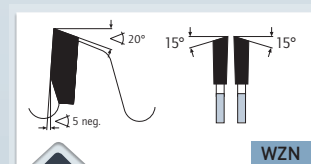











> Wechselzahn Negativ
> Alternate top bevel negative

MASCHINE · MACHINE

Spezialprogramm für Kapp- und Gehrungssägen, Radialkreissägen, Pendelkreissägen, oben liegende Kappkreissägen, Tischkreissägen, Abbundanlagen.

Special selection for chop- and mitre saws, radial saws, pendulum saws, top clipping saws, table saws, trimming saws.

✓ OPTIMAL · OPTIMAL ✓ GUT · GOOD ✓ MÖGLICH · POSSIBLE

✓		Kunststoffe, Plexiglas, Duro- und Thermoplaste	Plastics, plexiglass, acrylics, duro- and thermoplastics
✓		Weichholz, Hartholz, Exotenholz, Quer	Soft wood, hard wood, and exotic wood across the grain
✓		Leimholz, Tischler- und Furniersperrholz, Schichtholzplatten	Bonded wood, blockboard and veneer plywood, laminated wood
✓		Spanplatten, Hartfaserplatten, Platten ohne Belag LDF, MDF, HDF	Chipboard, hard fibre board, boards without laminate LDF, MDF, HDF
✓		Spanplatten, Hartfaserplatten Kunststoff beschichtet/furniert, MDF, HDF	Chipboard, hard fibre board, plastic-coated/veneered, MDF, HDF
✓		Furniere	Veneers
✓		Mineralische/acrylgebundene Massivplatten/Küchenplatten: Corian®, Noblan®, Hi-Macs®, Staron®, Rausolid®, Varicor®	Mineral/acrylic bound solid boards/kitchen worktops: Corian®, Noblan®, Hi-Macs®, Staron®, Rausolid®, Varicor®
✓		HPL-Duroplastische Schichtstoffplatten/Fassadenplatten: Trespa®, Resopal®, Duropal®, Formica®, Kronospan®, Decodur®	HPL High-Pressure-Laminate solid boards/façade panels: Trespa®, Resopal®, Duropal®, Formica®, Kronospan®, Decodur®
✓		Gips-Zement-Steinwollplatten, Eternit, GFK, CFK, HPL, Mineralwerkstoffe	Gypsum/Cement fibre boards, Rockwool, Eternit, GRP, CFK, HPL, Mineral material
✓		Profileleisten	Profiled wood

ANWENDUNG · APPLICATION

Für Querschnitte in Weich- und Hartholz, Holzmischwerkstoffe, Leimholz, Schichtholz, Plattenwerkstoffe furniert oder beschichtet.

Durch spezielles Hartmetall auch hervorragend für Kunststoffe wie kunststoffbeschichtete Profile, dünnes Acrylglas, Duroplast-Profil und Leisten (hohe Zähnezahl wählen).

Ebenfalls für harte Thermoplaste wie PA, PE, PS, POM, ABS.

Durch die negative Zahnform ist das Sägeblatt besser von Hand zu führen und wird nicht in das Schnittgut gezogen.

For cross cuts in soft and hard wood, wooden materials, glued wood, plywood, veneered or coated boards.

Due to special carbide also excellent for plastics such as: plastic laminated profiles, thin acrylic glass, duroplast profiles and strips (high number of teeth recommended).

Also for hard thermoplastics such as PA, PE, PS, POM, ABS.

Due to the negative tooth shape, that saw blade can be guided easier by hand and is not pulled into the material to be cut.



Video



1 

2 

3 

4 

5 

6 

7 

8 

9 





10 

Art. 100 101 102

Kapp- und Gehrungskreissägeblätter Wechselzahn/negativ
Chop- and mitre circular saws alternate top bevel tooth/negative

Art. 11.1450

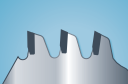
GOLD-STAR LINE 

Art.							€
111450.210.010	• 210	2,8/1,8	30	24 WZN	2-7-42	-	26,95
111450.210.020	• 210	2,8/1,8	30	48 WZN	2-7-42	-	41,15
111450.216.010	• 216	2,8/1,8	30	24 WZN	2-7-42	-	29,80
111450.216.020	• 216	2,8/1,8	30	48 WZN	2-7-42	-	41,15
111450.216.030	• 216	2,8/1,8	30	60 WZN	2-7-42	-	45,70
111450.216.040	• 216	2,8/1,8	30	80 WZN	2-7-42	-	57,75
111450.250.010	• 250	3,2/2,2	30	24 WZN	UNI	✓	34,65
111450.250.020	• 250	3,2/2,2	30	40 WZN	UNI	✓	46,70
111450.250.030	• 250	3,2/2,2	30	60 WZN	UNI	✓	58,35
111450.250.040	• 250	3,2/2,2	30	80 WZN	UNI	✓	67,20
111450.260.010	• 260	2,5/1,8	30	48 WZN	UNI	✓	56,40
111450.260.020	• 260	2,5/1,8	30	60 WZN	UNI	✓	71,40
111450.260.030	• 260	2,5/1,8	30	80 WZN	UNI	✓	76,95
111450.300.010	• 300	3,2/2,2	30	72 WZN	UNI	✓	70,20
111450.305.010	• 305	2,6/1,8	30	32 WZN	UNI	✓	54,55
111450.305.020	• 305	2,6/1,8	30	48 WZN	UNI	✓	57,40
111450.305.030	• 305	2,6/1,8	30	60 WZN	UNI	✓	65,60
111450.305.040	• 305	2,6/1,8	30	72 WZN	UNI	✓	71,95
111450.305.050	• 305	2,6/1,8	30	96 WZN	UNI	✓	85,50
111450.305.060	▲ 305	2,6/1,8	30	100 WZN	UNI	✓	83,20
111450.350.010	• 350	4,4/2,8	30	42 WZN	UNI	✓	94,05
111450.400.010	• 400	4,4/2,8	30	48 WZN	UNI	✓	107,20
111450.420.010	• 420	4,2/2,8	40/30	48 WZN	2-10-60+2-11-63+2-12-64	✓	115,25
111450.420.020	• 420	3,5/2,5	40/30	84 WZN	2-10-60+2-11-63+2-12-64	✓	156,30
111450.450.010	• 450	4,4/2,8	30	54 WZN	UNI	✓	122,95
111450.500.010	• 500	4,4/2,8	30	60 WZN	UNI	✓	143,90
111450.550.010	• 550	4,8/3,4	30	64 WZN	UNI	✓	182,55
111450.600.010	• 600	5,4/4,0	30	72 WZN	UNI	✓	228,35

UNI = 2-7-42 + 2-9-46,40 + 2-10-60

Eine große Vision braucht
einen zuverlässigen Partner.

Great visions need a
reliable partner.

KARNASCH – Made for Professionals

POWER.
PRECISION.
PERFORMANCE.

Karnasch®
PROFESSIONAL TOOLS

1



2



3



4



5



6



7



8



9



10



Art.
100
101
102

Karnasch® HARTMETALL-BESTÜCKTE KREISSÄGEBLÄTTER CARBIDE TIPPED CIRCULAR SAW BLADES

Art. **11.1460**



Formatieren · Fertigschnitt · Harte Kunststoffe · Abrasive Werkstoffe
Panel-sizing · Finishing cut · Hard plastics · Abrasive materials

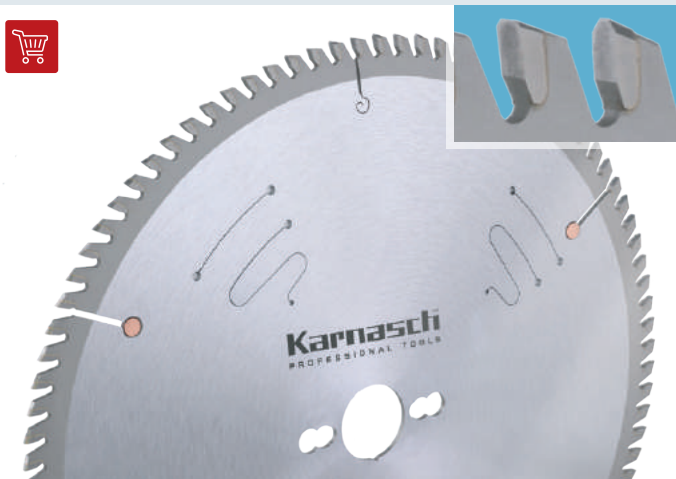

✓ OPTIMAL · OPTIMAL ✓ GUT · GOOD ✓ MÖGLICH · POSSIBLE

✓		Kunststoffe, Plexiglas, Duro- und Thermoplaste	Plastics, plexiglass, acrylics, duro- and thermoplastics
✓		Spanplatten, Hartfaserplatten Kunststoff beschichtet/furniert, MDF, HDF	Chipboard, hard fibre board, plastic-coated/veneered, MDF, HDF
✓		Mineralische/acrylgebundene Massivplatten/Küchenplatten: Corian®, Noblan®, Hi-Macs®, Staron®, Rausolid®, Varicor®	Mineral/acrylic bound solid boards/kitchen worktops: Corian®, Noblan®, Hi-Macs®, Staron®, Rausolid®, Varicor®
✓		HPL-Duroplastische Schichtstoff- platten/Fassadenplatten: Trespa®, Resopal®, Duropal®, Formica®, Kronospan®, Decodur®	HPL High-Pressure-Laminate solid boards/façade panels: Trespa®, Resopal®, Duropal®, Formica®, Kronospan®, Decodur®
✓		Gips-Zement-Steinwollplatten, Eternit, GFK, CFK, HPL, Mineral- werkstoffe	Gypsum/Cement fibre boards, Rockwool, Eternit, GRP, CFK, HPL, Mineral material

- 1
- 2
- 3
- 4
- 5
- 6
- 7
- 8
- 9
- 10

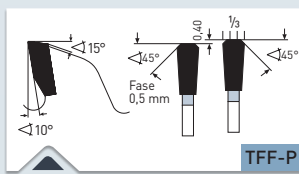

- > Trapez-Flachzahn (Flachzahn mit Fase)
- > Triple-chip/flat tooth (flat tooth with chamfer on both sides)

MASCHINE · MACHINE

Für Formatkreissägen, Plattensägen, Tischkreissägen

For sizing saws, panel saws, bench saws

ANWENDUNG · APPLICATION

Zum Formatieren von Platten in verschiedenen Dicken, Paketschnitte aus Thermoplaste wie: PVC, PE, PA, ABS, PS, POM.

Hervorragend auch zum schneiden von Kunststoffprofilen sowie für Fertigschnitte in beidseitig Kunststoffbeschichtete Span- und Faserwerkstoffe/Platten vorzugsweise in Verbindung mit Ritzer.

Durch spezielles Hartmetall auch gut bei abrasiven zu schnellem Schneidenverschleiß führenden Verbundstoffen wie faserverstärkte Gipskartonplatten, GFK, CFK.

Ebenfalls ideal für Duroplaste wie HPL Schichtstoff (Trespa, Resopal) und Mineralwerkstoffe wie Corian, Noblan, Staron usw.

For sizing panels of various thicknesses, cutting stacks made of thermoplastics such as: PVC, PE, PA, ABS, PS, POM.

Excellent also for cutting plastic profiles and finishing cuts in double-side plastic coated chip- and hard fibre materials/boards in combination with scoring sawblades.





Due to special carbide teeth also good for cutting abrasive, heavy machining and abrading materials such as HPL, high-pressure-laminate (Trespa, Resopal) and mineral materials such as corian, noblan, staron etc.

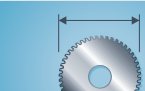
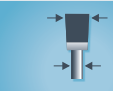

Formatieren · Fertigschnitt · Harte Kunststoffe · Abrasive Werkstoffe
Panel-sizing · Finishing cut · Hard plastics · Abrasive materials

Art. 11.1460

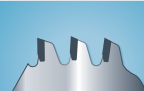
GOLD-STAR LINE 

Art.							€
111460.250.010	• 250	3,2/2,2	30	60 TFF-P	UNI	✓	73,60
111460.250.020	• 250	3,2/2,2	30	80 TFF-P	UNI	✓	92,30
111460.300.010	• 300	3,2/2,2	30	72 TFF-P	UNI	✓	89,80
111460.300.020	• 300	3,2/2,2	30	96 TFF-P	UNI	✓	108,05
111460.303.010	• 303	3,2/2,2	30	60 TFF-P	UNI	✓	78,65
111460.303.020	• 303	3,2/2,2	30	72 TFF-P	UNI	✓	89,80
111460.303.030	• 303	3,2/2,2	30	96 TFF-P	UNI	✓	108,05
111460.350.010	• 350	3,2/2,2	30	84 TFF-P	UNI	✓	106,70
111460.350.020	• 350	3,2/2,2	30	108 TFF-P	UNI	✓	128,95
111460.400.010	• 400	3,5/2,5	30	120 TFF-P	UNI	✓	142,95

UNI = 2-7-42 + 2-9-46,40 + 2-10-60

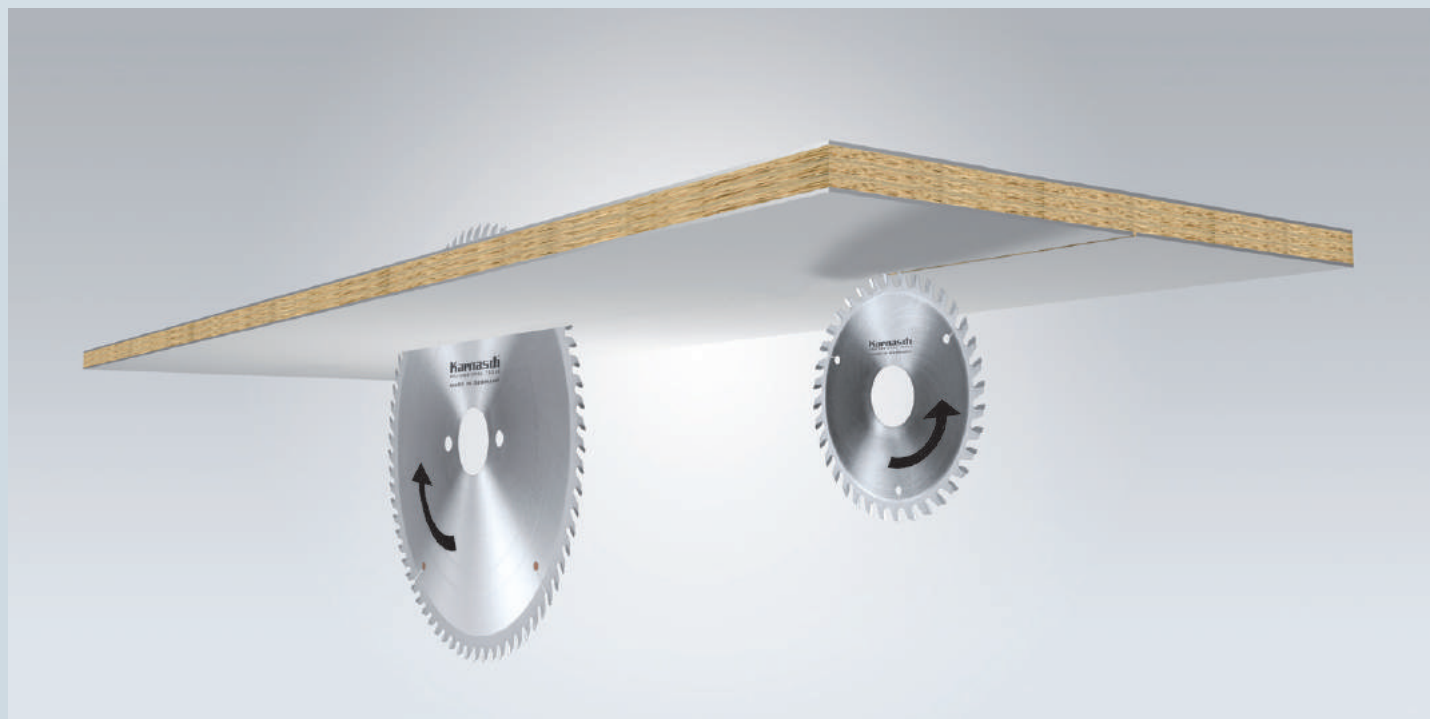

Bei Kunststoff/Melamin beschichtete Plattenwerkstoffe Vorritzen empfohlen. Ritzer siehe Seite 669. Sägen von beschichteten/furnierten Plattenwerkstoffe ohne Vorritzer siehe Seite 615

For plastic coated/melamine boards scoring recommended. Scorer see page 669. Cutting of coated/veneered boards without scorer see page 615

1



2



3



4



5



6



7



8



9



10



Art.
100
101
102

Karnasch® HARTMETALL-BESTÜCKTE KREISSÄGEBLÄTTER CARBIDE TIPPED CIRCULAR SAW BLADES

Art. **11.1470**



Formatieren · Fertigschnitt Trapez-Flachzahn
Panel-sizing · finishing cut triple chip/flat tooth

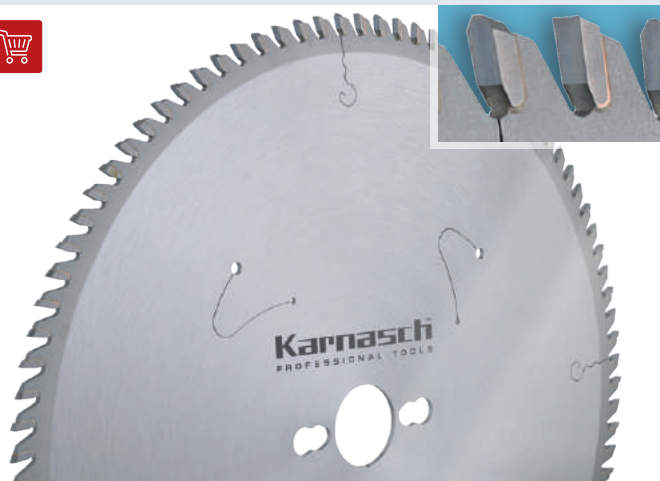

✓ OPTIMAL · OPTIMAL ✓ GUT · GOOD ✓ MÖGLICH · POSSIBLE

✓		Kunststoffe, Plexiglas, Duro- und Thermoplaste	Plastics, plexiglass, acrylics, duro- and thermoplastics
✓		Spanplatten, Hartfaserplatten, Platten ohne Belag LDF, MDF, HDF	Chipboard, hard fibre board, boards without laminate LDF, MDF, HDF
✓		Spanplatten, Hartfaserplatten Kunststoff beschichtet/furniert, MDF, HDF	Chipboard, hard fibre board, plastic-coated/veneered, MDF, HDF
✓		Mineralische/acrylgebundene Massivplatten/Küchenplatten: Corian®, Noblan®, Hi-Macs®, Staron®, Rausolid®, Varicor®	Mineral/acrylic bound solid boards/kitchen worktops: Corian®, Noblan®, Hi-Macs®, Staron®, Rausolid®, Varicor®
✓		HPL-Duroplastische Schichtstoffplatten/Fassadenplatten: Trespa®, Resopal®, Duropal®, Formica®, Kronospan®, Decodur®	HPL High-Pressure-Laminate solid boards/façade panels: Trespa®, Resopal®, Duropal®, Formica®, Kronospan®, Decodur®

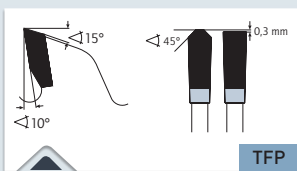

> Trapez-Flachzahn Positiv
> Triple-chip/flat tooth positive

ANWENDUNG · APPLICATION

Für Fertigschnitte in thermoplastische Vollplatten (Acrylglas, PMMA, Polyäthylen, Polyamid usw.) sowie duroplastische Vollplatten (Schichtstoffe, HPL, Hartpapier, Trespa, Resopal, Multiplex).

Weiterhin für polymergebundene Kunststoffe, Mineralwerkstoffe wie Corian, Noblan, Hi-Macs, Staron, Rausolid usw.

Hervorragend ebenfalls für Fertigschnitte in beidseitig Kunststoffbeschichteten Plattenwerkstoffe, vorzugsweise in Verbindung mit Vorritzer.

Ideal auch zum schneiden von Kunststoff-Profilen.

For finishing cuts in solid thermoplastic boards (PMMA, acrylic glass, polyethylene, polyamide etc.) and solid duroplastic boards (HPL-high-pressure-laminate, HP-Hardpaper, phenolic resin bonded paper, phenolic laminated cotton sheets, Trespa, Resopal, Multiplex).

Also for polymer-bound plastics, mineral materials such as: Corian, Noblan, Hi-Macs, Staron, Rausolid etc.

Excellent also for finishing cuts in double-side plastic coated boards, preferably in combination with coring sawblades.

Ideal also for cutting plastic profiles.

MASCHINE · MACHINE

Für Formatkreissägen, Plattensägen, Tischkreissägen





For sizing saws, panel saws, bench saws



Formatieren · Fertigschnitt Trapez-Flachzahn
Panel-sizing · finishing cut triple chip/flat tooth

Art. 11.1470

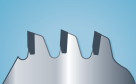
GOLD-STAR LINE

Art.							€
111470.220.010	• 220	3,2/2,2	30	64 TFP	UNI	-	60,75
111470.250.010	• 250	3,2/2,2	30	60 TFP	UNI	✓	66,20
111470.250.020	• 250	3,2/2,2	30	80 TFP	UNI	✓	76,15
111470.300.010	• 300	3,2/2,2	30	72 TFP	UNI	✓	76,10
111470.300.020	• 300	3,2/2,2	30	96 TFP	UNI	✓	88,50
111470.303.010	• 303	3,2/2,2	30	60 TFP	UNI	✓	72,35
111470.303.020	• 303	3,2/2,2	30	72 TFP	UNI	✓	76,10
111470.303.030	• 303	3,2/2,2	30	96 TFP	UNI	✓	88,50
111470.350.010	• 350	3,5/2,5	30	84 TFP	UNI	✓	99,55
111470.350.020	• 350	3,5/2,5	30	108 TFP	UNI	✓	105,60
111470.400.010	• 400	3,5/2,5	30	120 TFP	UNI	✓	123,25

UNI = 2-7-42 + 2-9-46,40 + 2-10-60

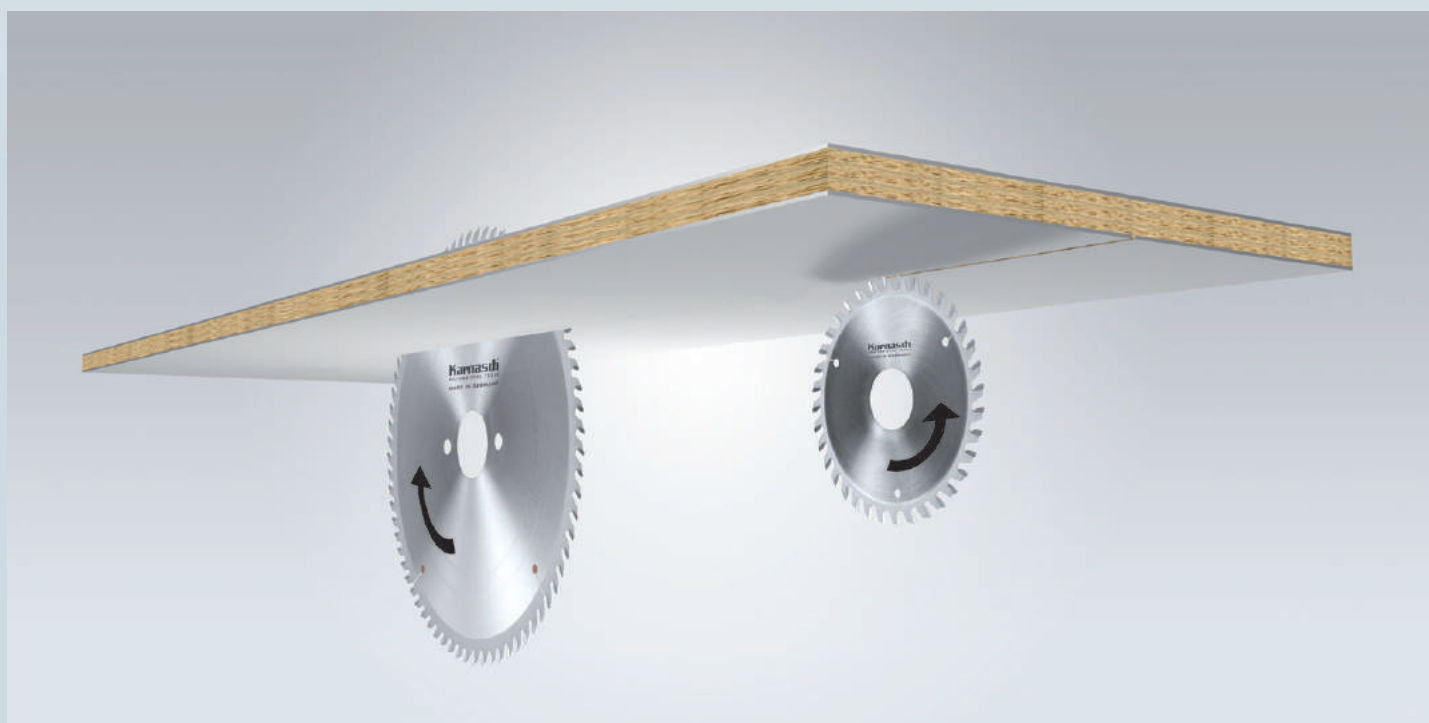

Bei Kunststoff/Melamin beschichtete Plattenwerkstoffe Vorritzen empfohlen. Ritzer siehe Seite 669. Sägen von beschichteten/furnierten Plattenwerkstoffe ohne Vorritzer siehe Seite 615

For plastic coated/melamine boards scoring recommended. Scorer see page 669. Cutting of coated/veneered boards without scorer see page 615

1



2



3



4



5



6



7



8



9



10



Art.
100
101
102

Bau · Universal
Construction · Universal

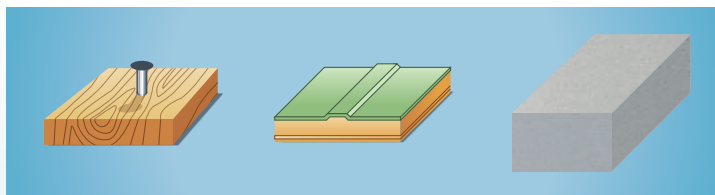

Die Berechnung von V_c und f_z für handgeführte Maschinen bei denen in der Regel die Drehzahl nicht einstellbar ist macht wenig Sinn. Weiterhin werden mit Universalblättern oftmals weiche und harte Werkstoffe in einem Werkstück kombiniert gesägt. Zum Beispiel Holz mit Nägeln, Kunststoffe mit Stahleinlage, Bleche mit PU/Schaum-Füllung usw.

Hier ist Fingerspitzengefühl und "herantasten" gefragt. Auf der untenstehenden Tabelle geben wir grobe Richtwerte der empfohlenen Drehzahl in gängige Materialien.

The calculation of V_c and F_z for handheld machines is mostly pointless as the mobile machines are normally operated with manual feed and the parameter (e.g. rpm) are not adjustable.

Furthermore, soft and hard materials are often combined in one workpiece.

For example, wood with nails, plastic materials combined with inside steel frame (window frames), sheet material with PU / foam filling, etc. In this case you have to test and follow your "feeling".

In the table below we give a rough guide to the recommended speed in common materials.

Drehzahl n (U/min) • Revolution per minute n (rpm)

	1000	1500	2000	2500	2850	3000	4000	4500	5000	5600	6000	8000	9000	10000	12000	18000
80 Ø	4,5	6,5	8,5	10,5	12	13	17	19	21	23,5	26	34	38	42	52	76
90 Ø	5	7	9,5	12	13,5	14	19	21	24	26,5	28	38	42	48	56	84
100 Ø	5,5	8	10,5	13	15	16	21	24	26	29	32	42	48	52	54	96
120 Ø	6,5	9,5	13	16	18	19	26	28	32	35	38	52	56	64	76	112
125 Ø	7	10	13,5	16,5	18,5	19,5	27	29	33	36,5	39	54	59	66	78	118
140 Ø	8	11	15	18	21	22	30	33	36	41	44	60	66	72	88	132
150 Ø	8,5	12	15,5	19,5	22,5	23,5	31,5	33,5	39	44	47	63	70,5	78,5	94,5	141,5
160 Ø	9	13	17	21	24	26	34	38	42	47	52	68	76	84	104	152
180 Ø	10	14	19	24	27	28	38	42,5	48	53	56	76	85	96	118	170
200 Ø	11	16	21	26	30	32	42	47	52	58,5	64	84	94	104	128	188
225 Ø	12	18	24	30	33,5	36	48	58	60	66	72	96	106	120	144	212
250 Ø	14	20	26	33	37	40	52	59	66	73,5	80	104	118	132	160	236
300 Ø	17	24	31,5	40	45	48	63	71	80	88	96	126	142	160	192	284
350 Ø	19	28	36,5	47	52	56	73	88	94	105	112	146	166	188	224	332
400 Ø	22	32	42	54	60	64	84	94	108	117	128	168	188	216	256	376
450 Ø	24	35,5	47	59	67,5	70,5	94,5	106	118	132	141,6	188	211	236	283	424
500 Ø	27	40	53	67	74,5	80	106	118	134	146,5	160	212	236	268	320	472

Schnittgeschwindigkeit in m/s · Cutting speed in m/s

1 Baustahl, Edelstahl, Dünnbleche, Sandwichmaterial
 Mild steel, stainless steel, thin iron sheets, sandwich material

2 NE-Metalle, Kunststoffe, Holzwerkstoffe
 Non ferrous metals, plastics, wooden materials

- 1
- 2
- 3
- 4
- 5
- 6
- 7
- 8
- 9
- 10

Art.
100
101
102

Bau · Universal
Construction · Universal

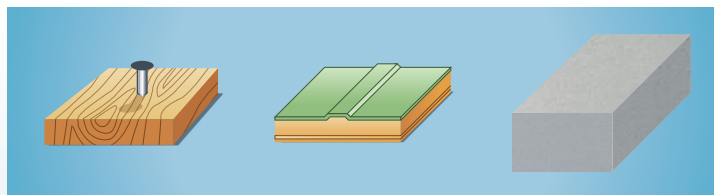

Art. Ø mm	Type	Anwendung · Application	
10.7100 Ø mm 136-500 	Universal/Stahl · NE-Metalle · Kunststoffe · Sandwich	Schwerpunkt ist das Trennen von Blechen/Profilen aus Baustahl bis zu 6 mm Wandstärke. Auch gut zum Trennen von NE-Metallen, Kunststoffen, Sandwichmaterial.	592
	Universal/Steel · Non-ferrous metals · Plastics · Sandwich	Focus is on the cutting of sheet metals/profiles of mild steel up to 6 mm wall thickness. Also excellent for cutting non-ferrous metals, plastics, sandwich materials.	
10.7200 Ø mm 250-355 	Universal-Pro/Stahl · NE-Metalle · Kunststoffe · Sandwich	Schwerpunkt ist das Trennen von Blechen/Profilen aus Baustahl bis zu 8 mm Wandstärke. Auch gut zum Trennen von NE-Metallen, Kunststoffen, Sandwichmaterial.	593
	Universal-Pro/Steel · Non-ferrous metals · Plastics · Sandwich	Focus is on the cutting of sheet metals/profiles of mild steel up to 8 mm wall thickness. Also excellent for cutting non-ferrous metals, plastics, sandwich materials.	
10.7400 Ø mm 136-500 	Universal/Dünobleche · Sandwich · NE-Metalle · Kunststoffe	Schwerpunkt ist das Trennen von dünnwandigen Blechen/Profilen aus Baustahl bis ca. 3 mm. Sandwichmaterialien mit dünnen Deckschichten 0,2-1 mm, sowie dünne NE-Metalle und Kunststoffe.	594
	Universal/Thin sheets · Sandwich · Non-ferrous metals · Plastics	Focus is on the cutting of thin-walled sheet metals/profiles up to 3 mm. Excellent for sandwich materials within layers 0,2-1mm and thin walled non-ferrous metals and plastic materials.	
10.8000 Ø mm 136-500 	Universal/NE-Metalle · Kunststoffe · Sandwich	Universalblatt für das Bauhandwerk, Ladenbau, Messebau, Renovierungsarbeiten.	595
	Universal/Non-ferrous metals · Plastics · Sandwich	Universal blade for construction, shop fitting, booth building, renovation.	
10.8055 Ø mm 120-500 	Winkelschleifer + Brutal Einweg-Sägeblätter	Universalblatt zum Trennen "fast" aller Materialien. Sogar mit dem Winkelschleifer.	597
	Angle Grinder + Brutal disposable saw blades	Universal blade for cutting "almost" any material. Even with the angle grinder.	

1



2



3



4



5



6



7



8



9



10



Art.
100
101
102

Bau · Universal
Construction · Universal

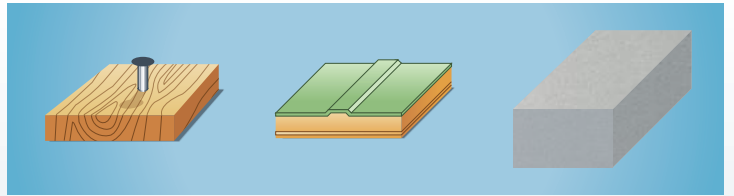

- 1
- 2
- 3
- 4
- 5
- 6
- 7
- 8
- 9
- 10

Art. Ø mm	Type	Anwendung · Application	
11.1250 Ø mm 136-700 	Bausäge	Für den harten Allroundeinsatz auf der Baustelle.	598
	Construction saw	For hard, all-round application on the building site.	
11.1260 Ø mm 136-700 	Super Bausäge	Für den extrem harten Allroundeinsatz auf der Baustelle. Das Bausägeblatt mit höchster Standzeit und guter Schnittqualität.	599
	Super construction saw	For extreme tough all-round application on the building site. The construction blade with the highest service life and good cutting quality.	
11.1350 Ø mm 160-350 	Diamant Universal	Durch DP (Polykristalliner Diamant) ideal zum Trennen extrem abrasiver, zu hohem Schneidenverschleiß führender Materialien.	600
	Diamond Universal	Due to DP (polycrystalline diamond) excellent for cutting extreme abrasive, heavy machining and abrading materials.	
11.1430 Ø mm 120-500 	Harte Kunststoffe · Abrasive Werkstoffe · Fertigschnitt/ Dünnschnitt	Durch spezielles Hartmetall ideal für Fertigschnitte in dünne Platten/Profile aus Kunststoff und abrasive, zu hohem Schneidenverschleiß führende Materialien.	601
	Hard plastics · Abrasive materials · Finishing-cut / Thin-cut	Due to special carbide ideal for finishing-cuts in thin-walled plates and profiles of plastics and abrasive, heavy machining/abrading material.	

Art.
100
101
102

Keine TOP-Leistung ohne Kontrolle.

Die Karnasch High-Performance Qualitätssicherung
für Werkzeuge mit herausragenden Eigenschaften.

No TOP-Performance without control.

The Karnasch high-performance quality assurance for
tools with outstanding features.

1



2



3



4



5



6



7



8



9



10



Art.
100
101
102

POWER.
PRECISION.
PERFORMANCE.

www.karnasch.tools

Karnasch®
PROFESSIONAL TOOLS

Art. **10.7100**

Universal/Stahl · NE-Metalle · Kunststoffe · Sandwich
Universal/Steel · Non-ferrous metals · Plastics · Sandwich

GOLD-STAR LINE



✓ OPTIMAL · OPTIMAL ✓ GUT · GOOD ✓ MÖGLICH · POSSIBLE

✓		Baustahl	Mild steel
✓		Ne-Metall wie Alu, Messing, Kupfer	Non ferrous materials like alu, copper, brass
✓		Dünnbleche, Sandwich Material, Verbundstoffe	Thin iron sheets, sandwich material, composites
✓		Kunststoffe, Plexiglas, Duro- und Thermoplaste	Plastics, plexiglass, acrylics, duro- and thermoplastics

ANWENDUNG · APPLICATION

Schwerpunkt ist das Trennen von Profilmaterial sowie Bleche bis ca. 6 mm Wandstärke. Die höhere Zähnezahl ist bis ca. 3 mm Wandstärke geeignet. Für noch höhere Standzeiten und zum Trennen bis zu 8 mm Wandstärke siehe unsere neuen **Super Dry-Cutter Baustähle** Blätter. (Art. 10.7200 / Seite 539).

The focus is on cutting profile material and sheet metals up to 6 mm wall thickness. The higher number of teeth is suitable up to 3 mm thickness. For higher service lives and cutting up to 8 mm thickness see our new **Super Dry-Cutter mild steel sheets**. (item.10.7200 / page 539).

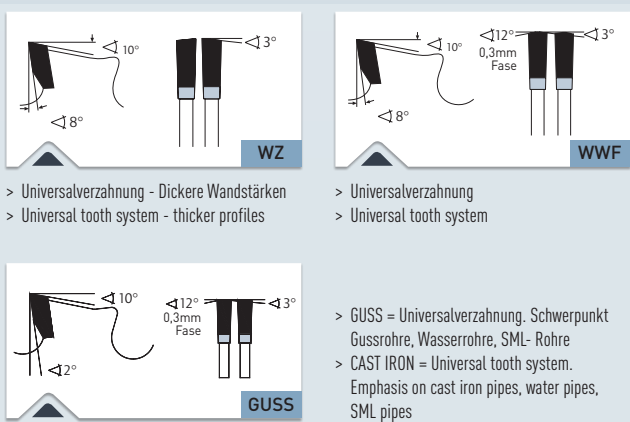

MASCHINE · MACHINE

Für Handkreissägen, Tauchsägen, Kapp- und Gehrungssägen, Radialarmsägen, Tisch- und Formatkreissägen, akkubetriebene Maschinen und passend ebenfalls für sogenannte DRY-CUTTER Maschinen mit reduzierten Drehzahlen wie zum Beispiel: JEPSON, RIDGID, ELU, RYOBI...

For portable machines, cross-cut saws, panel and giding saws, mitre saws, table and radial arms saws, battery-driven saws and suitable also for so-called DRY CUTTER machines with reduced speeds such as: Jepson, RIDGID, ELU, RYOBI...

Bei Stahl ist es vorteilhaft mit reduzierten Drehzahlen (min⁻¹) zu arbeiten (siehe Tabelle unten). Die Verwendung von Schneidspray oder Mecut-wachs erhöht wesentlich die Standzeit (Schneidöle siehe ab Seite 711).

For steel, it is beneficial to work at reduced speeds (see table below). Use of cutting spray or Mecut wax increases the service life (coolants see from page 711)

Ø 160-200 mm = 3500-3000 min⁻¹/rpm

Ø 210-250 mm = 2800-1900 min⁻¹/rpm

Ø 260-305 mm = 1800-1500 min⁻¹/rpm

Ø 350-400 mm = 1500-1000 min⁻¹/rpm

Trennen von Dünnblech bis ca. 3 mm Wandstärke sowie Sandwichmaterial siehe Art. 10.7400 Seite 541

Trennen von Edelstahl bis ca. 4 mm siehe Art. 10.7300 Seite 540

Trennen von Aluprofilen/Alublechen siehe Art. 10.8000 Seite 546 / Art. 11.1100 Seite 553 / Art. 11.1120 Seite 555

Trennen von Holz, Kunststoffen, NE-Metallen wie Alu, Baustähle siehe Art. 10.8055 Seite 543

Cutting thin sheet up to approx. 3mm wall thickness and sandwich material: see item 10.7400 page 541

Cutting stainless steel up to approx. 4mm: see item 10.7300 page 540

Cutting of aluminium profiles/sheets: see item 10.8000 page 546 / item 11.1100 page 553 / item 11.1120 page 555

Cutting of wood, plastics, non-ferrous materials like aluminium, mild steels: see item 10.8055 page 543

Art.	Ø	Teile	Teile	Teile	Teile	Teile	Teile	Teile	€
107100.136.010	● 136	2,0/1,4	20/10	30 WZ	2-6-32	-	-	-	32,45
107100.150.010	● 150	2,2/1,6	20/16	30 WZ	2-6-32	-	-	-	32,75
107100.160.010	● 160	2,2/1,6	20/16	30 WZ	2-6-32	-	-	-	33,65
107100.180.010	● 180	2,2/1,6	30/20	34 WZ	UNI 1	-	-	-	37,55
107100.185.010	● 185	2,2/1,6	20/16	34 WZ	2-6-32	-	-	-	37,55
107100.190.010	● 190	2,2/1,6	30	38 WZ	UNI 1	-	-	-	38,45
107100.200.010	● 200	2,2/1,8	30	40 WZ	UNI 1	-	-	-	42,95
107100.210.010	● 210	2,2/1,8	30	40 WZ	UNI 1	-	-	-	43,55
107100.216.010	● 216	2,2/1,8	30	42 WZ	UNI 1	-	-	-	46,25
107100.230.010	● 230/235	2,2/1,8	30	44 WZ	UNI 1	-	-	-	47,15
107100.250.010	● 250	2,2/1,8	30/25,4	48 WWF	UNI 1 + UNI 2	✓	✓	✓	59,15
107100.250.020	● 250	2,2/1,8	30/25,4	60 WWF	UNI 1 + UNI 2	✓	✓	✓	75,65
107100.260.010	● 260	2,2/1,8	30	60 WWF	UNI 1 + UNI 2	✓	✓	✓	81,35
107100.270.010	● 270	2,2/1,8	30	60 WWF	UNI 1 + UNI 2	✓	✓	✓	82,85
107100.280.010	● 280	2,2/1,8	30	60 WWF	UNI 1 + UNI 2	✓	✓	✓	84,35
107100.300.010	● 300	2,2/1,8	30	60 WWF	UNI 1 + UNI 2	✓	✓	✓	85,55
107100.300.020	● 300	2,2/1,8	30	80 WWF	UNI 1 + UNI 2	✓	✓	✓	104,15
107100.305.010	● 305	2,2/1,8	25,4	60 WWF	-	✓	✓	✓	83,15
107100.305.020	● 305	2,2/1,8	25,4	80 WWF	-	✓	✓	✓	104,15
107100.320.010	● 320	2,2/1,8	30/25,4	84 WWF	UNI 1 + UNI 2	✓	✓	✓	107,15
107100.330.010	● 330	2,4/2,0	32/30	84 WWF	UNI 2	✓	✓	✓	108,35
107100.350.010	● 350	2,4/2,0	30	80 WWF	UNI 1 + UNI 2	✓	✓	✓	108,35
107100.355.010	● 355	2,4/2,0	25,4	60 GUSS	-	✓	✓	✓	94,55
107100.355.020	● 355	2,4/2,0	25,4	80 WWF	-	✓	✓	✓	108,35
107100.355.030	● 355	2,4/2,0	25,4	90 WWF	1-12-55,4	✓	✓	✓	115,55
107100.400.010	● 400	3,0/2,5	30	84 WWF	UNI 1 + UNI 2	✓	✓	✓	138,35
107100.420.010	● 420	3,0/2,5	30	84 WWF	UNI 1 + UNI 2	✓	✓	✓	153,95
107100.450.010	● 450	3,4/2,8	30	90 WWF	UNI 1 + UNI 2	✓	✓	✓	169,25
107100.500.010	● 500	3,4/2,8	30	100 WWF	UNI 1 + UNI 2	✓	✓	✓	201,05

UNI 1 = 2-7-42 + 2-9-46,4 UNI 2 = 2-10-60 + 2-11-63 + 2-12-64 ● Gefertigt/Manufactured 232,50 mm



Universal-Pro/Stahl · NE-Metalle · Kunststoffe · Sandwich
Universal-Pro/Steel · Non-ferrous metals · Plastics · Sandwich

Art. **10.7200**

GOLD-STAR LINE 

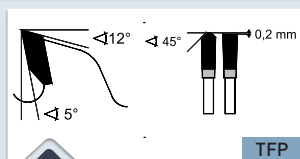

TFP

- > Trapez Flach Positiv
- > Triple-chip / flat tooth positive

MASCHINE · MACHINE

Für Handkreissägen, Tauchsägen, Kapp- und Gehrungssägen, Radialarmsägen, Tisch- und Formatkreissägen, akkubetriebene Maschinen und passend ebenfalls für sogenannte DRY-CUTTER Maschinen mit reduzierten Drehzahlen wie zum Beispiel: JEPSON, RIDGID, ELU, RYOBI...

For portable machines, cross-cut saws, panel and sizing saws, mitre saws, table and radial arms saws, battery-driven saws and suitable also for so-called DRY CUTTER machines with reduced speeds such as: JEPSON, RIDGID, ELU, RYOBI...

Bei Stahl ist es vorteilhaft mit reduzierten Drehzahlen (min^{-1}) zu arbeiten (siehe Tabelle unten). Die Verwendung von Schneidspray oder Mecut-wachs erhöht wesentlich die Standzeit (Schneidöle siehe ab Seite 711).

For steel, it is beneficial to work at reduced speeds (see table below). Use of cutting spray or Mecut wax increases the service life (coolants see from page 711)

Ø 160-200 mm = 3500-3000 min^{-1} /rpm

Ø 210-250 mm = 2800-1900 min^{-1} /rpm

Ø 260-305 mm = 1800-1500 min^{-1} /rpm

Ø 350-400 mm = 1500-1000 min^{-1} /rpm

Weitere Abmessungen siehe Art. 10.7100 Seite 538

Trennen von Dünnschleif bis ca. 3 mm Wandstärke sowie Sandwichmaterial siehe Art. 10.7400 Seite 541

Trennen von Edelstahl bis ca. 4 mm siehe Art. 10.7300 Seite 540

Trennen von Aluprofilen/ Alublechen siehe Art. 10.8000 Seite 546 / Art. 11.1100 Seite 553 / Art. 11.1120 Seite 555

Trennen von Holz, Kunststoffen, NE-Metallen wie Alu, Baustähle siehe Art. 10.8055 Seite 543

For other sizes, see item 10.7100 page 538





Cutting thin sheet up to approx. 3mm wall thickness and sandwich material: see item 10.7400 page 541

Cutting stainless steel up to approx. 4mm: see item 10.7300 page 540

Cutting of aluminium profiles/sheets: see item 10.8000 page 546 / item 11.1100 page 553 / item 11.1120 page 555

Cutting of wood, plastics, non-ferrous materials like aluminium, mild steels: see item 10.8055 page 543

- ✓ OPTIMAL · OPTIMAL
- ✓ GUT · GOOD
- ✓ MÖGLICH · POSSIBLE

✓		Baustahl	Mild steel
✓		Ne-Metall wie Alu, Messing, Kupfer	Non ferrous materials like alu, copper, brass
✓		Dünnschleif, Sandwich Material, Verbundstoffe	Thin iron sheets, sandwich material, composites
✓		Kunststoffe, Plexiglas, Duro- und Thermoplaste	Plastics, plexiglass, acrylics, duro- and thermoplastics

ANWENDUNG · APPLICATION

Schwerpunkt ist das Trennen von Blechen/Profilen aus Baustahl bis zu 8 mm Wandstärke.







Weiterhin gut geeignet zum Trennen von Blechen/Profilen aus NE-Metallen (Alu, Kupfer, Messing) und Kunststoffen bis ca. 12 mm Wandstärke.

Ebenfalls ausgezeichnet für eine Vielzahl von Sandwich-Materialien und Verbundstoffen.

Focus is on the cutting sheet metals/profiles of mild steel up to 8mm wall thickness.

Also highly suitable for cutting sheets/profiles from non-ferrous metals (aluminium, copper, brass) and plastics up to 12mm wall thickness.

Also excellent for a variety of sandwich materials and composites.

Art.							€
107200.250.010	● 250	2,2/1,8	30	48 TFP	UNI 1 + UNI 2	✓	68,75
107200.255.010	● 255	2,2/1,8	25,4	48 TFP	-	✓	68,05
107200.300.010	● 300	2,2/1,8	30	60 TFP	UNI 1 + UNI 2	✓	91,70
107200.305.010	● 305	2,2/1,8	25,4	60 TFP	-	✓	90,95
107200.350.010	● 350	2,4/2,0	30	72 TFP	UNI 1 + UNI 2	✓	114,60
107200.355.010	● 355	2,4/2,0	25,4	72 TFP	-	✓	114,05

UNI 1 = 2-7-42 + 2-9-46,4 UNI 2 = 2-10-60 + 2-11-63 + 2-12-64



Video



593

1



2



3



4



5



6



7



8



9



10



Art.
100
101
102

Karnasch® HARTMETALL-BESTÜCKTE KREISSÄGEBLÄTTER CARBIDE TIPPED CIRCULAR SAW BLADES

Art. **10.7400**



Universal/Dünnbleche · Sandwich · NE-Metalle · Kunststoffe

Universal/Thin sheets · Sandwich · Non-ferrous metals · Plastics

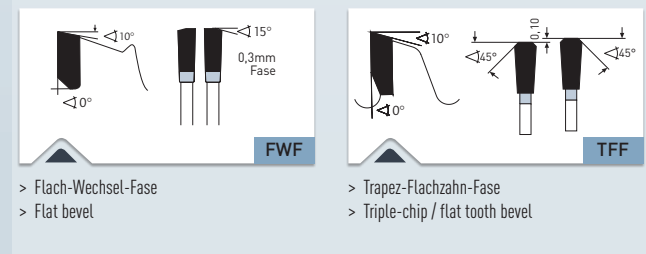

MASCHINE · MACHINE

Für Handkreissägen, Tauchsägen, Kapp- und Gehrungssägen, Radialarmsägen, Tisch- und Formatkreissägen, akkubetriebene Maschinen und passend ebenfalls für sogenannte DRY-CUTTER Maschinen mit reduzierten Drehzahlen wie zum Beispiel: JEPSON, RIDGID, ELU, RYOBI...

For portable machines, cross-cut saws, panel and sizing saws, mitre saws, table and radial arms saws, battery-driven saws and suitable also for so-called DRY CUTTER machines with reduced speeds such as: Jepson, RIDGID, ELU, RYOBI...

✓ OPTIMAL · OPTIMAL ✓ GUT · GOOD ✓ MÖGLICH · POSSIBLE

✓		Dünnbleche, Sandwich Material, Verbundstoffe	Thin iron sheets, sandwich material, composites
✓		Baustahl	Mild steel
✓		Ne-Metall wie Alu, Messing, Kupfer	Non ferrous materials like alu, copper, brass
✓		Kunststoffe, Plexiglas, Duro- und Thermoplaste	Plastics, plexiglass, acrylics, duro- and thermoplastics

ANWENDUNG · APPLICATION

Schwerpunkt ist das Trennen von dünnwandigen Blechen/Profilen aus Baustahl bis zu 3 mm Wandstärke.

Hervorragend für Sandwichmaterialien mit dünnen Deckschichten aus Stahl/Alu/Kunststoffen von ca. 0,2-1 mm

Weiterhin gut geeignet zum Trennen von Blechen/Profilen aus Ne-Metallen (Alu, Kupfer, Messing) und Kunststoffen bis ca. 5 mm Wandstärke.

Focus is on the cutting thin-walled sheet metal/steel profiles up to 3mm wall thickness.

Great for sandwich materials with thin layers of steel/aluminium/plastics of about 0.2-1mm

Also highly suitable for cutting sheets/profiles from non-ferrous metals (Aluminium, copper, brass) and plastics up to 5mm wall thickness.

Art.							€
107400.136.010	● 136	2,0/1,6	20/10	38 FWF	2-6-32	-	33,35
107400.160.010	● 160	2,0/1,6	20/16	42 FWF	2-6-32	-	37,85
107400.180.010	● 180	2,2/1,6	30/20	48 FWF	UNI 1	-	41,45
107400.185.010	● 185	2,2/1,6	20/16	48 FWF	2-6-32	-	41,45
107400.190.010	● 190	2,2/1,6	30	48 FWF	UNI 1	-	42,95
107400.200.010	● 200	2,2/1,6	30	54 FWF	UNI 1	-	57,05
107400.210.010	● 210	2,2/1,6	30	54 FWF	UNI 1	-	57,05
107400.216.010	● 216	2,2/1,8	30	54 FWF	UNI 1	-	57,05
107400.230.010	● 230/235	2,2/1,8	30	54 FWF	UNI 1	-	60,95
107400.250.010	● 250	2,2/1,8	30	72 TFF	UNI 1 + UNI 2	✓	82,55
107400.255.010	● 255	2,2/1,8	25,4	72 TFF	-	✓	85,85
107400.260.010	● 260	2,2/1,8	30	72 TFF	UNI 1 + UNI 2	✓	86,75
107400.270.010	● 270	2,2/1,8	30	72 TFF	UNI 1 + UNI 2	✓	87,05
107400.300.010	● 300	2,2/1,8	30	84 TFF	UNI 1 + UNI 2	✓	97,85
107400.305.010	● 305	2,2/1,8	25,4	84 TFF	-	✓	97,85
107400.320.010	● 320	2,2/1,8	30/25,4	96 TFF	UNI 1 + UNI 2	✓	119,75
107400.330.010	● 330	2,4/2,0	32/30	96 TFF	UNI 2	✓	121,55
107400.350.010	● 350	2,4/2,0	30	100 TFF	UNI 1 + UNI 2	✓	122,15
107400.355.010	● 355	2,4/2,0	25,4	100 TFF	-	✓	122,15
107400.400.010	● 400	3,0/2,5	30	110 TFF	UNI 1 + UNI 2	✓	180,95
107400.420.010	● 420	3,0/2,5	30	110 TFF	UNI 1 + UNI 2	✓	189,95
107400.450.010	● 450	3,4/2,8	30	120 TFF	UNI 1 + UNI 2	✓	222,65
107400.500.010	● 500	3,4/2,8	30	130 TFF	UNI 1 + UNI 2	✓	270,05

UNI 1 = 2-7-42 + 2-9-46,4 UNI 2 = 2-10-60 + 2-11-63 + 2-12-64 · ● Gefertigt/Manufactured 232,50 mm



Video

- 1
- 2
- 3
- 4
- 5
- 6
- 7
- 8
- 9
- 10

Art.
100
101
102

Universal/Dünobleche · Sandwich · NE-Metalle · Kunststoffe
Universal/Thin sheets · Sandwich · Non-ferrous metals · Plastics

Art. **10.8000**

GOLD-STAR LINE

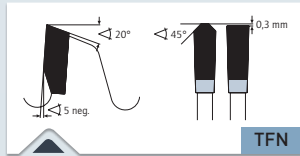
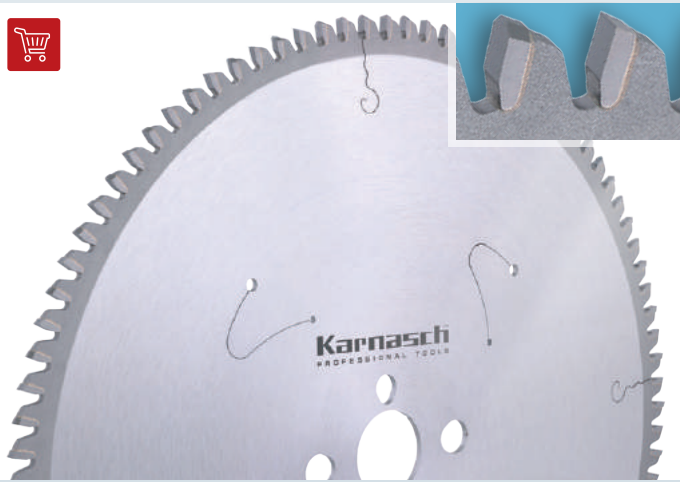

TFN

- > Trapez-Flachzahn Negativ
- > Triple-chip / flat tooth negative

MASCHINE · MACHINE

Für Elektro Handkreissägen, Tauchsägen, Kapp- und Gehrungssägen, Radialarmsägen, Tisch- und Formatkreissägen, Akkubetriebene Maschinen.

For portable circular saws, cross-cut saws, panel saws, sizing and mitre saws, table and radial arm saws, battery-driven saws.

✓ OPTIMAL · OPTIMAL ✓ GUT · GOOD ✓ MÖGLICH · POSSIBLE

✓		Kunststoffe, Plexiglas, Duro- und Thermoplaste	Plastics, plexiglass, acrylics, duro- and thermoplastics
✓		Ne-Metall wie Alu, Messing, Kupfer	Non ferrous materials like alu, copper, brass
✓		Mineralische/acrylgebundene Massivplatten/Küchenplatten: Corian®, Noblan®, Hi-Macs®, Staron®, Rausolid®, Varicor®	Mineral/acrylic bound solid boards/kitchen worktops: Corian®, Noblan®, Hi-Macs®, Staron®, Rausolid®, Varicor®
✓		HPL-Duroplastische Schichtstoffplatten/Fassadenplatten: Trespa®, Resopal®, Duropal®, Formica®, Kronospan®, Decodur®	HPL High-Pressure-Laminate solid boards/façade panels: Trespa®, Resopal®, Duropal®, Formica®, Kronospan®, Decodur®
✓		Dünobleche, Sandwich Material, Verbundstoffe	Thin iron sheets, sandwich material, composites
✓		Weichholz, Hartholz, Exotenholz, Quer	Soft wood, hard wood, and exotic wood across the grain
✓		Holz mit Einschlüssen wie Nägel, Klammern, Beton- und Mörtelreste	Wood with inclusions like nails, clips, concrete residues
✓		Gips-Zement-Steinwoolplatten, Eternit, GFK, CFK, HPL, Mineralwerkstoffe	Gypsum/Cement fibre boards, Rockwool, Eternit, GRP, CFK, HPL, Mineral material
✓		Gasbetonsteine	Autoclaved aerated concrete blocks

ANWENDUNG · APPLICATION

Das ideale Blatt für den Ladenbau, Messebau, Renovierungsarbeiten. Für eine Vielzahl von Materialien wie: Ne-Metalle, Kunststoffe, Plexiglas, Spanplatten, Thermo-Fassadenplatten. Weitere Alu-Negativ Blätter siehe Art. 11.1100 Seite 553 sowie Art. 11.1120 Seite 555.

The ideal blade for shop construction, trade fair construction, renovation work. For many materials such as: non-ferrous materials, plastics, plexiglas, chipboard, thermo façade plates. Other aluminium negative sheets: see item 11.1100 page 553, and item 11.1120 page 555.

Art.							€
108000.120.010	● 120	2,8/2,0	20	34 TFN	-	-	33,65
108000.136.010	● 136	2,8/2,0	20/10	40 TFN	2-6-32	-	39,30
108000.150.010	● 150	2,8/2,0	20/16	42 TFN	2-6-32	-	40,50
108000.160.010	● 160	2,8/2,0	20/16	42 TFN	2-6-32	-	40,95
108000.165.010	● 165	2,8/2,0	20	48 TFN	2-6-32	-	44,20
108000.170.010	● 170	2,8/2,0	30	48 TFN	-	-	44,35
108000.180.010	● 180	2,8/2,0	30	48 TFN	UNI 1	-	44,90
108000.185.010	● 185	2,8/2,0	20/16	48 TFN	2-6-32	-	46,55
108000.190.010	● 190	2,8/2,0	30	54 TFN	UNI 1	-	49,55
108000.200.010	● 200	2,8/2,0	30	54 TFN	UNI 1	-	50,55
108000.210.010	● 210	2,8/2,0	30	54 TFN	UNI 1	-	51,25
108000.216.010	● 216	2,8/2,0	30	60 TFN	UNI 1	-	56,45
108000.216.020	● 216	2,8/2,0	30	80 TFN	UNI 1	-	67,75
108000.220.010	● 220	2,8/2,0	30	54 TFN	UNI 1	-	54,15
108000.230.010	● 230/235	2,8/2,0	30	64 TFN	UNI 1	-	56,75
108000.240.010	● 240	2,8/2,0	30	64 TFN	UNI 1	-	56,75
108000.250.010	● 250	3,2/2,5	30	60 TFN	UNI 1 + UNI 2	✓	70,65
108000.250.020	● 250	3,2/2,5	30	80 TFN	UNI 1 + UNI 2	✓	78,70
108000.250.030	● 250	2,8/2,2	30	100 TFN	UNI 1 + UNI 2	✓	97,35
108000.260.010	● 260	3,2/2,5	30	80 TFN	UNI 1 + UNI 2	✓	85,10
108000.270.010	● 270	3,2/2,5	30	88 TFN	UNI 1 + UNI 2	✓	86,95
108000.280.010	● 280	3,2/2,5	30	88 TFN	UNI 1 + UNI 2	✓	89,15
108000.300.010	● 300	3,2/2,5	30	72 TFN	UNI 1 + UNI 2	✓	84,55
108000.300.020	● 300	3,2/2,5	30	96 TFN	UNI 1 + UNI 2	✓	88,55
108000.300.030	● 300	2,8/2,2	30	120 TFN	UNI 1 + UNI 2	✓	115,50

UNI 1 = 2-7-42 + 2-9-46,40 UNI 2 = 2-10-60 + 2-11-63 + 2-12-64

● Gefertigt/Manufactured 232,50 mm



Video

595



10
Art.
100
101
102

Art. **10.8055**

Winkelschleifer + Brutal Einweg-Sägeblätter
Angle Grinder + Brutal disposable saw blades

GOLD-STAR LINE



✓ OPTIMAL · OPTIMAL ✓ GUT · GOOD ✓ MÖGLICH · POSSIBLE

✓		Baustahl	Mild steel
✓		Ne-Metall wie Alu, Messing, Kupfer	Non ferrous materials like alu, copper, brass
✓		Dünobleche, Sandwich Material, Verbundstoffe	Thin iron sheets, sandwich material, composites
✓		Kunststoffe, Plexiglas, Duro- und Thermoplaste	Plastics, plexiglass, acrylics, duro- and thermoplastics
✓		Weichholz, Hartholz, Exotenholz, Quer	Soft wood, hard wood, and exotic wood across the grain
✓		Holz mit Einschlüssen wie Nägel, Klammern, Beton- und Mörtelreste	Wood with inclusions like nails, clips, concrete residues
✓		Weichholz, Hartholz, Exotenholz Längs	Soft wood, hard wood, and exotic wood along the grain
✓		Leimholz, Tischler- und Furniersperrholz, Schichtholzplatten	Bonded wood, blockboard and veneer plywood, laminated wood
✓		Spanplatten, Hartfaserplatten, Platten ohne Belag LDF, MDF, HDF	Chipboard, hard fibre board, boards without laminate LDF, MDF, HDF
✓		Spanplatten, Hartfaserplatten Kunststoff beschichtet/furniert, MDF, HDF	Chipboard, hard fibre board, plastic-coated/veneered, MDF, HDF
✓		HPL-Duroplastische Schichtstoffplatten/Fassadenplatten: Trespa®, Resopal®, Duropal®, Formica®, Kronospan®, Decodur®	HPL High-Pressure-Laminate solid boards/façade panels: Trespa®, Resopal®, Duropal®, Formica®, Kronospan®, Decodur®
✓		Furniere	Veneers
✓		Profileleisten	Profiled wood
✓		Gasbetonsteine	Autoclaved aerated concrete blocks
✓		Mineralische/acrylgebundene Massivplatten/Küchenplatten: Corian®, Noblan®, Hi-Macs®, Staron®, Rausolid®, Varicor®	Mineral/acrylic bound solid boards/kitchen worktops: Corian®, Noblan®, Hi-Macs®, Staron®, Rausolid®, Varicor®
✓		Gips-Zement-Steinwollplatten, Eternit, GFK, CFK, HPL, Mineralwerkstoffe	Gypsum/Cement fibre boards, Rockwool, Eternit, GRP, CFK, HPL, Mineral material

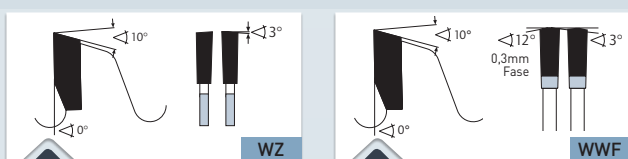

> Wechselzahn
> Alternate top bevel

> Wechselzahn-Fase
> Alternate top bevel+bevel

MASCHINE · MACHINE

Für Handkreissägen, Tauchsägen, Kapp- und Gehrungssägen, Radialarmsägen, Tisch- und Formatkreissägen, akkubetriebene Maschinen und passend ebenfalls für sogenannte DRY-CUTTER Maschinen mit reduzierten Drehzahlen wie zum Beispiel: JEPSON, RIDGID, ELU, RYOBI...

For portable machines, cross-cut saws, panel and sizing saws, mitre saws, table and radial arms saws, battery-driven saws and suitable also for so-called DRY CUTTER machines with reduced speeds such as: JEPSON, RIDGID, ELU, RYOBI...

Ø 160-200 mm = 3500-3000 min⁻¹/rpm

Ø 210-250 mm = 2800-1900 min⁻¹/rpm

Ø 260-305 mm = 1800-1500 min⁻¹/rpm

Ø 350-400 mm = 1500-1000 min⁻¹/rpm

Bei Stahl ist es vorteilhaft mit reduzierten Drehzahlen (min⁻¹) zu arbeiten (siehe Tabelle oben). Die Verwendung von Schneidspray oder Mecutwachs erhöht wesentlich die Standzeit (Schneidöle siehe ab Seite 711).

For steel, it is beneficial to work at reduced speeds (see table above). Use of cutting spray or Mecut wax increases the service life (for cutting oils, see from page 711)

Art. **10.8056** € **38,00**

Blätter 120 mm passen für Winkelschleifer 115 + 125 mm.

Blade diameter 120 mm suitable for angle grinder diameter 115-125 mm.



Verwendung in Europa nur erlaubt mit Schutzhaube (wird komplett mit Spindelmutter, Stirnlochschlüssel, Absaugstutzen und Bedienungsanleitung geliefert).



Use in Europe only permitted with protection cover (delivered completely with spindle nut, open-faced spanner, exhaust socket and operating instructions).

ANWENDUNG · APPLICATION

Brutal Einweg-Sägeblätter zum Sägen „fast“ aller Materialien. Ideal für Bau und Handwerk. Durch geringe Schnittbreite wenig Schnittverlust sowie Schnittwiderstand. Daher auch ideal für Akku-Maschinen.

Niedrigste Zähnezahl: Zum schnellen Trennen aller Arten von Hölzern (auch mit Nägeln, Klammern), Kunststoffen, NE-Metallen. Grober Schnitt.

Mittlere Zähnezahl: Zum Trennen aller angegebenen Materialien. Mittlere Schnittgüte (Zum Trennen von Baustählen, NE-Metalle empfehlen wir die höchste Zähnezahl).

Höchste Zähnezahl: Zum Trennen aller angegebenen Materialien. Vorzugsweise für alle Metalle, wie Baustähle, Alu und andere NE-Metalle.

Brutal disposable saw blades for sawing "almost" any material. Ideal for construction and crafts. The low cutting width leads to little cutting wastage and cutting resistance. Therefore also ideal for battery-powered machines.

Lowest tooth number: For fast cutting of all kinds of woods (also with nails, clamps, plastics, non-ferrous materials). Coarse cut.

Medium tooth number: For cutting of all specified materials. Medium cutting quality (for cutting of mild steels, non-ferrous metals, we recommend the highest number of teeth).

Highest tooth number: For cutting of all specified materials. Preferably for all metals like mild steels, aluminium and other non-ferrous metals.







Video

Winkelschleifer + Brutal Einweg-Sägeblätter
Angle Grinder + Brutal disposable saw blades

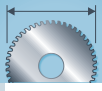
Art. **10.8055**

GOLD-STAR LINE 

Art.						€
108055.120.010	● *120	2,0/1,4	25,4/22	14 WZ	-	16,05
108055.120.020	● *120	2,0/1,4	25,4/22	24 WZ	-	23,70
108055.120.030	● *120	2,0/1,4	25,4/22	40 WWF	-	35,88
108055.136.010	● 136	2,0/1,4	20/10	16 WZ	-	18,35
108055.136.020	● 136	2,0/1,4	20/10	30 WZ	-	28,95
108055.136.030	● 136	2,0/1,4	20/10	40 WWF	-	36,55
108055.160.010	● 160	2,0/1,4	20/16	18 WZ	2-6-32	20,50
108055.160.020	● 160	2,0/1,4	20/16	30 WZ	2-6-32	29,70
108055.160.030	● 160	2,0/1,4	20/16	40 WWF	2-6-32	37,50
108055.165.010	● 165	2,0/1,4	20	18 WZ	2-6-32	21,10
108055.165.020	● 165	2,0/1,4	20	30 WZ	2-6-32	30,30
108055.165.030	● 165	2,0/1,4	20	40 WWF	2-6-32	38,25
108055.180.005	▲ 180	2,2/1,6	22,22	10 WZ	-	23,95
108055.180.010	● 180	2,0/1,4	30/22/20	20 WZ	UNI 1	24,60
108055.180.020	● 180	2,0/1,4	30/22/20	34 WZ	UNI 1	32,30
108055.180.030	● 180	2,0/1,4	30/22/20	48 WWF	UNI 1	45,95
108055.185.010	● 185	2,0/1,4	20/16	20 WZ	2-6-32	23,45
108055.185.020	● 185	2,0/1,4	20/16	34 WZ	2-6-32	34,10
108055.185.030	● 185	2,0/1,4	20/16	48 WWF	2-6-32	44,80
108055.190.010	● 190	2,0/1,4	30	20 WZ	UNI 1	22,70
108055.190.020	● 190	2,0/1,4	30	34 WZ	UNI 1	33,30
108055.190.030	● 190	2,0/1,4	30	48 WWF	UNI 1	44,05
108055.210.010	● 210	2,0/1,4	30	22 WZ	UNI 1	26,00
108055.210.020	● 210	2,0/1,4	30	36 WZ	UNI 1	36,85
108055.210.030	● 210	2,0/1,4	30	48 WWF	UNI 1	46,25
108055.216.010	● 216	2,0/1,4	30	24 WZ	UNI 1	28,35
108055.216.020	● 216	2,0/1,4	30	36 WZ	UNI 1	37,85
108055.216.030	● 216	2,0/1,4	30	48 WWF	UNI 1	47,25
108055.225.010	● 225	2,0/1,4	30	24 WZ	UNI 1	28,35
108055.225.020	● 225	2,0/1,4	30	36 WZ	UNI 1	37,85
108055.225.030	● 225	2,0/1,4	30	48 WWF	UNI 1	47,25
108055.230.010	● 230/235 ●	2,0/1,4	30/22	24 WZ	UNI 1	29,90
108055.230.020	● 230/235 ●	2,0/1,4	30/22	36 WZ	UNI 1	39,05
108055.230.030	● 230/235 ●	2,0/1,4	30/22	48 WWF	UNI 1	48,20
108055.250.010	● 250	2,4/1,8	30/25,4	28 WZ	UNI 1 + UNI 2	37,35
108055.250.020	● 250	2,4/1,8	30/25,4	44 WZ	UNI 1 + UNI 2	49,60
108055.250.030	● 250	2,4/1,8	30/25,4	60 WWF	UNI 1 + UNI 2	61,75
108055.260.010	● 260	2,4/1,8	30	28 WZ	UNI 1 + UNI 2	37,35
108055.260.020	● 260	2,4/1,8	30	44 WZ	UNI 1 + UNI 2	49,60
108055.260.030	● 260	2,4/1,8	30	60 WWF	UNI 1 + UNI 2	61,80
108055.270.010	● 270	2,4/1,8	30	30 WZ	UNI 1 + UNI 2	39,75
108055.270.020	● 270	2,4/1,8	30	46 WZ	UNI 1 + UNI 2	51,95
108055.270.030	● 270	2,4/1,8	30	60 WWF	UNI 1 + UNI 2	62,70
108055.280.010	● 280	2,4/1,8	30	32 WZ	UNI 1 + UNI 2	42,35
108055.280.020	● 280	2,4/1,8	30	48 WZ	UNI 1 + UNI 2	54,70
108055.280.030	● 280	2,4/1,8	30	60 WWF	UNI 1 + UNI 2	64,00
108055.300.010	● 300	2,4/1,8	30	32 WZ	UNI 1 + UNI 2	44,95
108055.300.020	● 300	2,4/1,8	30	48 WZ	UNI 1 + UNI 2	57,40
108055.300.030	● 300	2,4/1,8	30	60 WWF	UNI 1 + UNI 2	66,85
108055.305.010	● 305	2,4/1,8	30/25,4	32 WZ	UNI 1 + UNI 2	46,10
108055.305.020	● 305	2,4/1,8	30/25,4	48 WZ	UNI 1 + UNI 2	58,30
108055.305.030	● 305	2,4/1,8	30/25,4	60 WWF	UNI 1 + UNI 2	67,60
108055.320.010	● 320	2,4/1,8	30/25,4	32 WZ	UNI 1 + UNI 2	47,75
108055.320.020	● 320	2,4/1,8	30/25,4	48 WZ	UNI 1 + UNI 2	60,40
108055.320.030	● 320	2,4/1,8	30/25,4	60 WWF	UNI 1 + UNI 2	69,85
108055.330.010	● 330	2,6/2,0	32/30	36 WZ		52,40
108055.330.020	● 330	2,6/2,0	32/30	54 WZ	UNI 2	66,45
108055.330.030	● 330	2,6/2,0	32/30	72 WWF		80,20
108055.350.010	● 350	2,6/2,0	30	36 WZ	UNI 1 + UNI 2	57,20
108055.350.020	● 350	2,6/2,0	30	54 WZ	UNI 1 + UNI 2	71,25
108055.350.030	● 350	2,6/2,0	30	72 WWF	UNI 1 + UNI 2	85,30
108055.355.010	● 355	2,6/2,0	30/25,4	36 WZ	UNI 1 + UNI 2	57,60
108055.355.020	● 355	2,6/2,0	30/25,4	54 WZ	UNI 1 + UNI 2	71,40
108055.355.030	● 355	2,6/2,0	30/25,4	72 WWF	UNI 1 + UNI 2	85,50
108055.400.010	● 400	2,8/2,2	30	42 WZ	UNI 1 + UNI 2	81,35
108055.400.020	● 400	2,8/2,2	30	60 WZ	UNI 1 + UNI 2	98,75
108055.400.030	● 400	2,8/2,2	30	84 WWF	UNI 1 + UNI 2	122,30
108055.420.010	● 420	2,8/2,2	30	42 WZ	UNI 1 + UNI 2	83,45
108055.420.020	● 420	2,8/2,2	30	60 WZ	UNI 1 + UNI 2	101,15
108055.420.030	● 420	2,8/2,2	30	84 WWF	UNI 1 + UNI 2	124,35
108055.450.010	● 450	3,2/2,5	30	48 WZ	UNI 1 + UNI 2	100,90
108055.450.020	● 450	3,2/2,5	30	72 WZ	UNI 1 + UNI 2	124,10
108055.450.030	● 450	3,2/2,5	30	96 WWF	UNI 1 + UNI 2	147,30
108055.500.010	● 500	3,4/2,8	30	54 WZ	UNI 1 + UNI 2	125,30
108055.500.020	● 500	3,4/2,8	30	84 WZ	UNI 1 + UNI 2	154,05
108055.500.030	● 500	3,4/2,8	30	108 WWF	UNI 1 + UNI 2	177,20

UNI 1 = 2-7-42 + 2-9-46,4 UNI 2 = 2-10-60 + 2-11-63 + 2-12-64 ● Gefertigt/Manufactured 232,50 mm



Art. 100 101 102

Art. **11.1250**

Bausäge
Construction saw

GOLD-STAR LINE 



✓ OPTIMAL · OPTIMAL ✓ GUT · GOOD ✓ MÖGLICH · POSSIBLE

✓		Holz mit Einschlüssen wie Nägel, Klammern, Beton- und Mörtelreste	Wood with inclusions like nails, clips, concrete residues
✓		Weichholz, Hartholz, Exotenholz, Quer	Soft wood, hard wood, and exotic wood across the grain
✓		Weichholz, Hartholz, Exotenholz Längs	Soft wood, hard wood, and exotic wood along the grain
✓		Leimholz, Tischler- und Furniersperrholz, Schichtholzplatten	Bonded wood, blockboard and veneer plywood, laminated wood
✓		Spanplatten, Hartfaserplatten, Platten ohne Belag LDF, MDF, HDF	Chipboard, hard fibre board, boards without laminate LDF, MDF, HDF
✓		Gips-Zement-Steinwollplatten, Eternit, GFK, CFK, HPL, Mineralwerkstoffe	Gypsum/Cement fibre boards, Rockwool, Eternit, GRP, CFK, HPL, Mineral material
✓		Gasbetonsteine	Autoclaved aerated concrete blocks

- 1 
- 2 
- 3 
- 4 
- 5 
- 6 
- 7 
- 8 
- 9 
- 10 

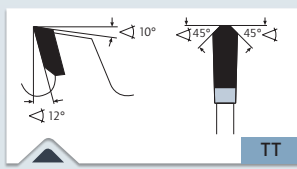

> Trapez-Trapezzahn
> Triple-chip/triple-chip teeth

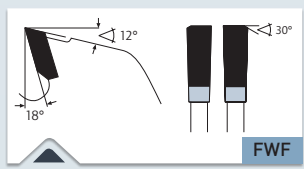

> Flachzahn Wechsel-Fase
> Flat tooth alternating bevel

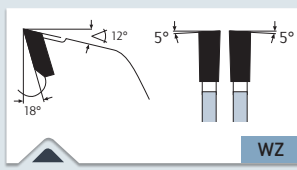

> Wechselzahn
> Alternate top bevel

ANWENDUNG · APPLICATION



Für den harten Allroundeinsatz auf der Baustelle. Schneidet sämtliche Bauhölzer längs und quer. Schaltafeln mit Mörtel, bzw. Blechummantelung, Paletten, Gasbetonsteine, Heraklith, Zementgebundene Faserplatten u.ä. Für höchste Standzeit + sauberen Schnitt siehe Superbausäge Code 11.1260 auf Seite 599.

For tough all-round application on the building site. Makes longitudinal and cross-cuts in all construction wood. Form-work boards with mortar or sheet metal casing, pallets, aerated concrete, Heraklith products, cemented fibreboard, and similar material. For the highest service life + clean cuts see the super construction saw blades, code 11.1260, on page 599.

MASCHINE · MACHINE

Für Tischkreissägen, Baukreissägen, Handkreissägen, Tauchsägen

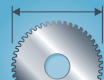
For table circular saws, construction circular saws, portable saws

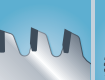
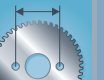
Art.						€
111250.136.010	• 136	2,6/1,6	20/10	10 TT	2-6-32	15,85
111250.160.010	• 160	2,6/1,6	20/16	12 TT	2-6-32	17,90
111250.180.010	• 180	2,8/1,8	30/20	12 TT	2-7-42	19,40
111250.185.010	• 185	2,8/1,8	20/16	12 TT	2-6-32	19,50
111250.190.010	• 190	2,8/1,8	30	14 TT	2-7-42	21,30
111250.210.010	• 210	2,8/1,8	30	14 TT	2-7-42	23,40
111250.216.010	• 216	2,8/1,8	30	14 TT	2-7-42	23,40
111250.230.010	• 230/235	2,8/1,8	30	16 TT	2-7-42	26,10
111250.250.010	• 250	3,2/2,2	30	20 TT	UNI	30,45
111250.300.010	• 300	3,2/2,2	30	24 FWF	UNI	35,00
111250.315.010	• 315	3,2/2,2	30	24 FWF	UNI	35,85
111250.350.010	• 350	3,5/2,5	30	28 FWF	UNI	44,25
111250.400.010	• 400	4,2/2,8	30	28 FWF	UNI	47,85
111250.450.010	• 450	4,2/2,8	30	32 FWF	UNI	61,30
111250.500.010	• 500	4,2/2,8	30	36 FWF	UNI	75,00
111250.600.010	• 600	4,2/3,0	30	40 WZ	UNI	118,65
111250.700.010	• 700	4,4/3,2	30	46 WZ	UNI	153,60

UNI = 2-7-42 + 2-9-46,40 + 2-10-60

• Gefertigt/Manufactured 232,50 mm



Video

Super Bausäge
Super construction saw

Art. 11.1260

GOLD-STAR LINE

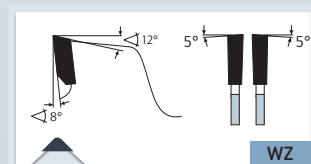
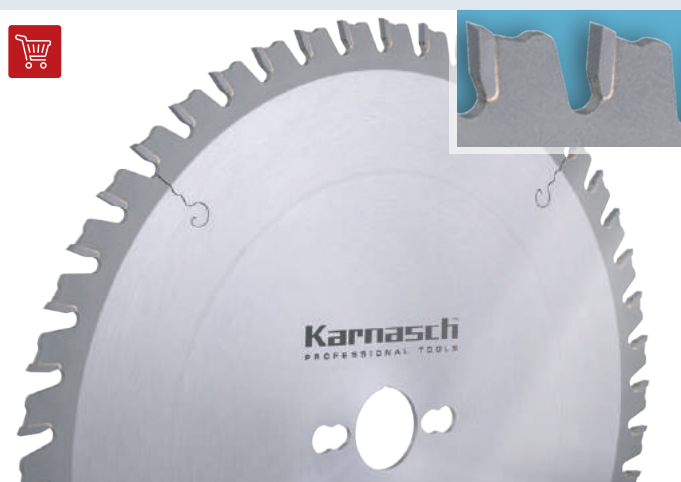

> Wechselzahn
> Alternate top bevel

MASCHINE · MACHINE

Für Handkreissägen, Tauchsägen, Kapp- und Gehrungssägen, Tischkreissägen, Formatkreissägen, Baukreissägen, Brennholzkreissägen, Pendelkreissägen, Zugkreissägen.

For portable circular saws, cutting and mitre saws, table circular saws, format circular saws, construction circular saws, firewood saws, pendulum saws, course saws.

ANWENDUNG · APPLICATION

Extrem robustes Blatt für das Bauhandwerk, Schreinereien, Palettenbauer, Dachdecker u.ä.

Höchste Standzeit und saubere Schnitte in: Bauhölzern längs und quer, Schalltafeln mit Mörtel bzw. Blechummantelung, Paletten, Gasbetonsteine, Heraklith- und zementgebundenen Faserplatten, Kunststoffen, Hartfaser- und Spanplatten, Leimholz, Corian, Eternit.

Sogar zum trennen vom Ne-Profilmaterial wie Alu, Messing, Kupfer.

Extremely durable blade for the building trade, carpenter's workshops, pallet manufacturers, roofers, and similar professions.

For the highest service life and clean cuts in: construction wood, formwork boards with mortar or sheet metal casing, pallets, aerated concrete, Heraklith products and cemented fibreboard, plastics, hard fibreboard and chipboard, laminated wood, Corian, Eternit.

Also for coarse cutting non-ferrous profiled material, such as aluminium, brass and copper.

✓ OPTIMAL · OPTIMAL ✓ GUT · GOOD ✓ MÖGLICH · POSSIBLE

✓		Holz mit Einschlüssen wie Nägel, Klammern, Beton- und Mörtelreste	Wood with inclusions like nails, clips, concrete residues
✓		Weichholz, Hartholz, Exotenholz, Quer	Soft wood, hard wood, and exotic wood across the grain
✓		Leimholz, Tischler- und Furniersperrholz, Schichtholzplatten	Bonded wood, blockboard and veneer plywood, laminated wood
✓		Spanplatten, Hartfaserplatten, Platten ohne Belag LDF, MDF, HDF	Chipboard, hard fibre board, boards without laminate LDF, MDF, HDF
✓		Gips-Zement-Steinwoolplatten, Eternit, GFK, CFK, HPL, Mineralwerkstoffe	Gypsum/Cement fibre boards, Rockwool, Eternit, GRP, CFK, HPL, Mineral material
✓		Gasbetonsteine	Autoclaved aerated concrete blocks
✓		Weichholz, Hartholz, Exotenholz Längs	Soft wood, hard wood, and exotic wood along the grain
✓		Spanplatten, Hartfaserplatten Kunststoff beschichtet/furniert, MDF, HDF	Chipboard, hard fibre board, plastic-coated/veneered, MDF, HDF
✓		Furniere	Veneers
✓		Profileleisten	Profiled wood
✓		Mineralische/acrylgebundene Massivplatten/Küchenplatten: Corian®, Noblan®, Hi-Macs®, Staron®, Rausolid®, Varicor®	Mineral/acrylic bound solid boards/kitchen worktops: Corian®, Noblan®, Hi-Macs®, Staron®, Rausolid®, Varicor®
✓		HPL-Duroplastische Schichtstoffplatten/Fassadenplatten: Trespa®, Resopal®, Duropal®, Formica®, Kronospan®, Decodur®	HPL High-Pressure-Laminate solid boards/façade panels: Trespa®, Resopal®, Duropal®, Formica®, Kronospan®, Decodur®
✓		Kunststoffe, Plexiglas, Duro- und Thermoplaste	Plastics, plexiglass, acrylics, duro- and thermoplastics
✓		Dünobleche, Sandwich Material, Verbundstoffe	Thin iron sheets, sandwich material, composites

Art.						€
111260.136.010	• 136	2,8/1,8	20/10	20 WZ	2-6-32	23,05
111260.150.010	• 150	2,8/1,6	20/16	24 WZ	2-6-32	26,25
111260.160.010	• 160	2,8/1,6	20/16	24 WZ	2-6-32	26,70
111260.170.010	• 170	2,8/1,8	30/20	24 WZ	2-7-42	28,10
111260.180.010	• 180	2,8/1,8	30/20	30 WZ	2-7-42	29,85
111260.185.010	• 185	2,8/1,8	20/16	30 WZ	2-6-32	31,30
111260.190.010	• 190	2,8/1,8	30	30 WZ	2-7-42	31,30
111260.200.010	• 200	2,8/1,8	30	30 WZ	2-7-42	32,75
111260.210.010	• 210	2,8/1,8	30	34 WZ	2-7-42	33,90
111260.216.010	• 216	2,8/1,8	30	34 WZ	2-7-42	35,35
111260.225.010	• 225	2,8/1,8	30	34 WZ	2-7-42	35,35
111260.230.010	• 230/235	2,8/1,8	30	34 WZ	2-7-42	35,35
111260.250.010	• 250	3,0/2,0	30	42 WZ	UNI	45,15
111260.260.010	• 260	3,0/2,0	30	42 WZ	UNI	50,70
111260.270.010	• 270	3,0/2,0	30	42 WZ	UNI	51,35
111260.300.010	• 300	3,2/2,2	30	48 WZ	UNI	51,85
111260.315.010	• 315	3,2/2,2	30	48 WZ	UNI	53,35
111260.350.010	• 350	3,2/2,2	30	54 WZ	UNI	66,65
111260.355.010	• 355	3,2/2,2	30	54 WZ	UNI	72,50
111260.400.010	• 400	3,5/2,5	30	60 WZ	UNI	74,45
111260.450.010	• 450	3,5/2,5	30	66 WZ	UNI	87,80
111260.500.010	• 500	4,0/2,8	30	72 WZ	UNI	115,85
111260.600.010	• 600	4,2/3,0	30	78 WZ	UNI	160,15
111260.700.010	• 700	4,2/3,2	30	84 WZ	UNI	195,85

UNI = 2-7-42 + 2-9-46,40 + 2-10-60 · • Gefertigt/Manufactured 232,50 mm



Video

599



10
Art.
100
101
102

Art. **11.1350**

Diamant Universal
Diamond Universal

GOLD-STAR LINE 

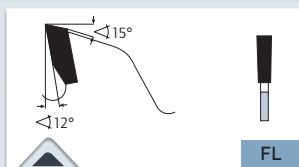

> Flachzahn
> Flat tooth

MASCHINE · MACHINE

Für Handkreissägen, Tauchsägen, Kapp- und Gehrungssägen, Tisch- und Formatkreissägen

For hand-held circular saws, mitre saws, cross-cut saws, table and sizing saws

ANWENDUNG · APPLICATION

Durch DP (Polykristalliner Diamant) Zähne ideal für Zuschnitte sowie Formatschnitte in extrem abrasive, zu hohen Schneidenschleiß führenden Materialien wie: Corian, Trespa, Laminat, MDF, Gips- und Zementgebundene Platten (Faserzement), Steinwollplatten, Heraklith, Eternit.

Blätter mit niedriger Zähnezahl wie: 160mm mit 4 Zähnen, 190mm mit 6 Zähnen, 230mm mit 6 Zähnen, 250mm mit 6 Zähnen und 300mm mit 8 Zähnen, sind speziell geeignet für Gips- und Zementgebundene Platten. (Faserzement)

Speziell hervorragend ebenfalls für Duroplaste wie: Glasfaserverstärkte sowie Kohlefaserverstärkte Kunststoffe (GFK, CFK), Carbon, Aramidfaserkunststoffe (AFK) HP, HPL, PUR.

Niedere Zahnreihe für Zuschnitte, höhere Zahnreihe für Formatschnitte. Achtung: Keine Fertigschnitt-Blatt (DP-Bestückung = 4mm). Fertigschnitt-Blätter siehe Art. 11.1370 Seite 576







Due to DP (Polycrystalline Diamond) teeth excellent for sizing, formatting, cross cuts in extreme abrasive, heavy machining and abrading materials such as: Corian, Trespa, laminates, MDF, gypsum and cement-bonded boards (fiber cement), Rockwool boards, Heraklith products, Eternit.







Circular saws with the lowest number of teeth as: 160mm with 4 teeth, 190mm with 6 teeth, 230mm with 6 teeth, 250mm with 6 teeth und 300mm with 8 teeth, are specially designed for gypsum and cement-bonded panels (fiber cement).

Also excellent for Duroplastic materials such as: Glas fibre plastic (GFK), Carbon fibre plastic (CFK), Carbon, Aramid fibre plastic (AFK), HP, HPL, PUR.

Lower tooth row for sizing, higher tooth row for format cuts. Attention: no finishing cut blade (DP-Tip height = 4mm). Finishing cut-blades see Art. 11.3070 page 576

✓ OPTIMAL · OPTIMAL ✓ GUT · GOOD ✓ MÖGLICH · POSSIBLE

✓		Kunststoffe, Plexiglas, Duro- und Thermoplaste	Plastics, plexiglass, acrylics, duro- and thermoplastics
✓		HPL-Duroplastische Schichtstoffplatten/Fassadenplatten: Trespa®, Resopal®, Duropol®, Formica®, Kronospan®, Decodur®	HPL High-Pressure-Laminate solid boards/façade panels: Trespa®, Resopal®, Duropol®, Formica®, Kronospan®, Decodur®
✓		Gips-Zement-Steinwollplatten, Eternit, GFK, CFK, HPL, Mineralwerkstoffe	Gypsum/Cement fibre boards, Rockwool, Eternit, GRP, CFK, HPL, Mineral material
✓		Gasbetonsteine	Autoclaved aerated concrete blocks
✓		Mineralische/acrylgebundene Massivplatten/Küchenplatten: Corian®, Noblan®, Hi-Macs®, Staron®, Rausolid®, Varicor®	Mineral/acrylic bound solid boards/kitchen worktops: Corian®, Noblan®, Hi-Macs®, Staron®, Rausolid®, Varicor®
✓		Spanplatten, Hartfaserplatten, Platten ohne Belag LDF, MDF, HDF	Chipboard, hard fibre board, boards without laminate LDF, MDF, HDF
✓		Spanplatten, Hartfaserplatten Kunststoff beschichtet/furniert, MDF, HDF	Chipboard, hard fibre board, plastic-coated/veneered, MDF, HDF

Art.							€
111350.160.005	● 160	2,2/1,6	20/16	4 FL	2-6-32,5	✓	39,70
111350.160.010	● 160	2,2/1,6	20/16	8 FL	2-6-32,5	✓	70,50
111350.160.020	● 160	2,2/1,6	20/16	30 FL	2-6-32,5	✓	209,10
111350.180.010	● 180	2,2/1,6	30/20	8 FL	2-7-42	✓	70,95
111350.190.005	● 190	2,2/1,6	30/20	6 FL	2-7-42	✓	54,90
111350.190.010	● 190	2,2/1,6	30/20	8 FL	2-7-42	✓	71,45
111350.190.020	● 190	2,2/1,6	30/20	30 FL	2-7-42	✓	225,45
111350.210.010	● 210	2,2/1,6	30	12 FL	UNI	✓	100,35
111350.210.020	● 210	2,2/1,6	30	30 FL	UNI	✓	252,05
111350.216.010	● 216	2,2/1,6	30	12 FL	UNI	✓	100,35
111350.216.020	● 216	2,2/1,6	30	30 FL	UNI	✓	252,05
111350.230.005	● 230	2,4/1,8	30	6 FL	UNI	✓	64,35
111350.230.010	● 230	2,4/1,8	30	15 FL	UNI	✓	133,95
111350.230.020	● 230	2,4/1,8	30	30 FL	UNI	✓	252,05
111350.250.005	● 250	2,4/1,8	30	6 FL	UNI	✓	65,90
111350.250.010	● 250	2,4/1,8	30	16 FL	UNI	✓	148,90
111350.250.020	● 250	2,4/1,8	30	40 FL	UNI	✓	339,30
111350.300.005	● 300	2,2/1,6	30	8 FL	UNI	✓	88,20
111350.300.010	▲ 300	2,2/1,6	30	30 FL	UNI	✓	325,30
111350.300.020	● 300	2,6/2,0	30	36 FL	UNI	✓	325,30
111350.300.030	● 300	2,6/2,0	30	48 FL	UNI	✓	422,85
111350.300.040	● 300	2,6/2,0	30	60 FL	UNI	✓	550,25
111350.350.010	● 350	2,8/2,2	30	60 FL	UNI	✓	586,65

▲ = Auslaufartikel / Discontinued · UNI = 2-7-42 + 2-9-46,40 + 2-10-60



Video

Universal/Harte Kunststoffe · Abrasive Werkstoffe · Fertigschnitt/Dünnschnitt
Universal/Hard plastics · Abrasive materials · Finishing-cut/Thin-cut

Art. 11.1430

GOLD-STAR LINE



✓ OPTIMAL · OPTIMAL ✓ GUT · GOOD ✓ MÖGLICH · POSSIBLE

✓		Kunststoffe, Plexiglas, Duro- und Thermoplaste	Plastics, plexiglass, acrylics, duro- and thermoplastics
✓		Mineralische/acrylgebundene Massivplatten/Küchenplatten: Corian®, Noblan®, Hi-Macs®, Staron®, Rausolid®, Varicor®	Mineral/acrylic bound solid boards/kitchen worktops: Corian®, Noblan®, Hi-Macs®, Staron®, Rausolid®, Varicor®
✓		HPL-Duroplastische Schichtstoffplatten/Fassadenplatten: Trespa®, Resopal®, Duropal®, Formica®, Kronospan®, Decodur®	HPL High-Pressure-Laminate solid boards/façade panels: Trespa®, Resopal®, Duropal®, Formica®, Kronospan®, Decodur®
✓		Gips-Zement-Steinwollplatten, Eternit, GFK, CFK, HPL, Mineralwerkstoffe	Gypsum/Cement fibre boards, Rockwool, Eternit, GRP, CFK, HPL, Mineral material
✓		Dünnbleche, Sandwich Material, Verbundstoffe	Thin iron sheets, sandwich material, composites

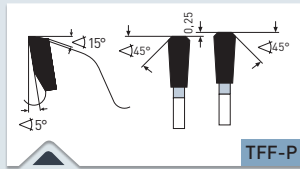

- > Trapez Flach Fase Positiv
- > Triple-chip/triple-chip teeth

MASCHINE · MACHINE

Für Handkreissägen, Tauchsägen, Tisch- und Formatkreissägen, Plattenaufteilsägen, Kappsägen, Akkusägen

For portable circular saws, bench- and sizing saws, panel sizing saws, cross-cut saws, cordless saws.

ANWENDUNG · APPLICATION

Durch spezielles Hartmetall/Zahnform ideal für Fertigschnitte in dünnen Platten und Profilmaterial aus harten Kunststoffen (Thermoplaste) wie: PVC, PE, PA, ABS, PS, POM PC, PMMA (Acrylglas) z.B. Hohlkammerplatten aus PMMA (Acrylglas).

Ebenfalls gut bei abrasiven, zu hohen Schneidenschleiß führenden Materialien wie: GFK, CFK, Zementplatten, Gipsfaserplatten, Eternit.

Excellent ebenfalls für Sandwichmaterialien mit dünnen Deckschichten (bis ca. 1 mm) aus Alu, Kunststoff (Bleche bis ca. 0,3 mm).

Durch dünne Schnittbreite wenig Kraftaufwand und Verschleiß. Daher auch ideal für Akku-Maschinen.

Due to special carbide / tooth geometry excellent for finishing cuts in thin plates and profiles made of hard plastics (thermoplastics) such as: PVC, PE, PA, ABS, PS, POM PC, PMMA e.g. hollow section boards of PMMA (acrylic glass).

Also good for abrasive, heavy machining and abrading materials such as: GFK, CFK, fibre cement panels, gypsum, fibre boards, eternit.

Also excellent for sandwich materials with thin layers (max. approx. 1mm) of aluminium, plastics (sheet metal approx. max. 0,3 mm).

Due to thin cutting width little cutting pressure and waste of material. Therefore also ideal for cordless machines.

Art.							€
111430.120.010	• 120	1,8/1,2	20	40 TFF-P	-	-	39,20
111430.160.010	• 160	1,8/1,2	20/16	56 TFF-P	2-6-32	-	47,60
111430.180.010	• 180	1,8/1,2	20/16	60 TFF-P	2-6-32	-	53,10
111430.190.010	• 190	1,8/1,2	30/20	60 TFF-P	2-7-42	-	53,70
111430.200.010	• 200	2,0/1,4	30	64 TFF-P	2-7-42	-	54,80
111430.210.010	• 210	2,0/1,4	30	64 TFF-P	2-7-42	-	55,65
111430.225.010	• 225	2,0/1,4	30	68 TFF-P	2-7-42	-	61,40
111430.230.010	• 230/235	2,0/1,4	30	68 TFF-P	2-7-42	-	62,15
111430.250.010	• 250	2,4/1,8	30	80 TFF-P	UNI	✓	73,55
111430.300.010	• 300	2,4/1,8	30	96 TFF-P	UNI	✓	89,15
111430.350.010	• 350	2,4/1,8	30	108 TFF-P	UNI	✓	103,80
111430.400.010	• 400	3,0/2,4	30	120 TFF-P	UNI	✓	123,25
111430.450.010	• 450	3,3/2,8	30	132 TFF-P	UNI	✓	190,35
111430.500.010	• 500	3,3/2,8	30	144 TFF-P	UNI	✓	245,75

• Gefertigt/Manufactured 232,50 mm · UNI = 2-7-42 + 2-9-46,40 + 2-10-60



Video

601

- 1
- 2
- 3
- 4
- 5
- 6
- 7
- 8
- 9
- 10

Art. 100 101 102

Abrasiv

Abrasive

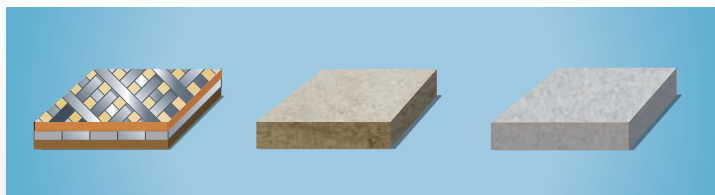

Dieses Kapitel hebt besonders die Bearbeitung von Werkstoffen hervor, die schwierig zu bearbeiten sind und zu hohem Schneidenschleiß führen

This chapter focuses on the machining of materials difficult to machine and causing high cutting edge wear.

Schnittwertempfehlungen · Recommended cutting values

Werkstoffgruppe Material Group	Werkstoffbeispiele Material examples	Vc (m/s) Schnittgeschwindigkeit Cutting speed	fz (mm/z) Vorschub pro Zahn Feed per tooth	
Gipsgebunden Gypsum bound	Gipsfaserplatten, Gipsfaserplatten mit MDF/Funier, Gipskartonplatten Gypsum fibre board, gypsum fibre board with MDF/Veneer, gypsum plaster board	40–65	0,1–0,25	
Zementgebunden Cement bound	Zementfaserplatten, Eternit Fibre cement board, Eternit	40–60	0,02–0,05	
Steinwollplatten Rockwool board	Rockwool	2–8	0,01–0,03	
Duroplaste Duroplastics	Glasfaserverstärkte und Kohlefaserverstärkte Kunststoffe GFK/CFK Glass fibre and carbon fibre reinforced plastics GFK/CFK	20–50	0,01–0,03	
	HPL-Schichtstoffplatten HPL (High-Pressure-Laminate)	Trespa®, Resopal®, Wodego®, Duropal®, Formica®, Unilin®, Kronospan®, Homapal®, Decodur®, Abet®	50–70	0,01–0,08
	Mineralwerkstoff Corian, Noblan, Hi-Macs, Staron, Rausolid Mineral material Corian, Noblan, Hi-Macs, Staron, Rausolid	50–70	0,02–0,04	
Mineralisch-Acrylge- bundene Materialien z.B. Küchenplatten/ Waschbecken	Corian®, Noblan®, Hi-Macs®, Staron®, Rausolid®, Varicor®	50-70	0,02-0,04	
Mineral-Acrylic bound materials e.g. Kitchen worktops/ sink				

Festlegung der Schnittgeschwindigkeit Vc
 Determination of cutting speed Vc

$$Vc \text{ (m/s)} = \frac{D \cdot \pi \cdot n}{60 \cdot 1000}$$

Vc (m/s) = Schnittgeschwindigkeit · Cutting speed

Vf (m/min) = Vorschubgeschwindigkeit · Feed rate

fz (mm/z) = Vorschub pro Zahn · Feed per tooth

D (mm) = Sägendurchmesser · Saw blade diameter

n (min⁻¹) = Drehzahl · rpm

Z = Anzahl der Zähne · Number of teeth

Festlegung der Vorschubgeschwindigkeit Vf
 Determination of feed rate Vf

$$Vf \text{ (m/min)} = \frac{fz \cdot n \cdot Z}{1000}$$

Festlegung der Drehzahl n
 Determination

$$n \text{ (min}^{-1}\text{)} = \frac{Vc \cdot 1000 \cdot 60}{D \cdot \pi}$$



Art.
100
101
102

Abrasive
Abrasive

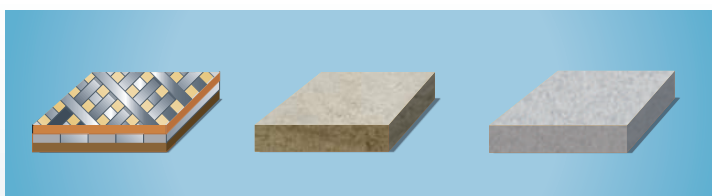

Art. Ø mm	Type	Anwendung · Application	
11.1350  Ø mm 160-350 	Diamant Universal	Durch DP (Polykristalliner Diamant) Zähne ideal für Zuschnitte sowie Formatschnitte in extrem abrasive, zu hohen Schneidenverschleiß führenden Materialien wie: Corian, Trespa, Laminat, MDF, Gips- und Zementgebundene Platten (Faserzement), Steinwollplatten, Heraklith, Eternit (CFK, GFK, Carbon).	605
	Diamond Universal	Due to DP (Polycrystalline Diamond) teeth excellent for sizing, formatting, cross cuts in extreme abrasive, heavy machining and abrading materials such as: Corian, Trespa, laminates, MDF, gypsum and cement-bonded boards (fiber cement), Rockwool boards, Heraklith products, Eternit (CFK, GFK, carbon).	
11.1370  Ø mm 250-350 	Diamant · Formatieren · Fertigschnitt · Harte Kunststoffe · Abrasive Werkstoffe	Durch DP (Polykristalliner Diamant) Zähne ideal zum Trennen extrem abrasiver, zu hohem Schneidenverschleiß führender Materialien.	607
	Diamond · Panel-sizing · Finishing cut · Hard plastics · Abrasive materials	Due to DP (Polychristalline Diamond) teeth excellent for cutting extreme abrasive, heavy machining and abrading materials.	
11.1430 Ø mm 120-500 	Harte Kunststoffe · Abrasive Werkstoffe · Fertigschnitt/ Dünnschnitt	Fertigschnitte in harte Kunststoffe und abrasive Materialien wie GFK, CFK, Zementfaserplatten/ Gipsfaserplatten, Eternit ...	609
	Hard plastics · abrasive materials · Finishing-cut / Thin-Cut	Finishing cuts in hard plastics and abrasive material such as: GFK, CFK, fibre cement panels, gypsum fiber boards, eternit ...	
11.1460 Ø mm 250-400 	Formatieren · Fertigschnitt · Harte Kunststoffe · Abrasive Werkstoffe	Formatieren von Platten/Profilen in verschiedenen Dicken aus harten Kunststoffen. Weiterhin gut bei abrasiven Werkstoffen wie GFK, CFK, Zementfaserplatten/Gipsfaserplatten, Eternit ...	611
	Panel-sizing · Finishing cut · Hard plastics · Abrasive Materials	For sizing panels/profiles in various thicknesses. Also very good in abrasive, heavy machining/abrading materials such as: GFK, CFK, fibre cement panels, gypsum fiber boards, eternit ...	



Art. **11.1350**

Diamant Universal
Diamond Universal

GOLD-STAR LINE 

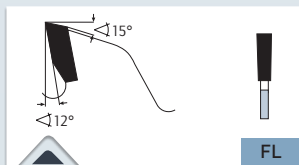







> Flachzahn
> Flat tooth

MASCHINE · MACHINE

Für Handkreissägen, Tauchsägen, Kapp- und Gehrungssägen, Tisch- und Formatkreissägen

For hand-held circular saws, mitre saws, cross-cut saws, table and sizing saws

✓ OPTIMAL · OPTIMAL ✓ GUT · GOOD ✓ MÖGLICH · POSSIBLE

✓		Kunststoffe, Plexiglas, Duro- und Thermoplaste	Plastics, plexiglass, acrylics, duro- and thermoplastics
✓		HPL-Duroplastische Schichtstoffplatten/Fassadenplatten: Trespa®, Resopal®, Duropal®, Formica®, Kronospan®, Decodur®	HPL High-Pressure-Laminate solid boards/façade panels: Trespa®, Resopal®, Duropal®, Formica®, Kronospan®, Decodur®
✓		Gips-Zement-Steinwollplatten, Eternit, GFK, CFK, HPL, Mineralwerkstoffe	Gypsum/Cement fibre boards, Rockwool, Eternit, GRP, CFK, HPL, Mineral material
✓		Gasbetonsteine	Autoclaved aerated concrete blocks
✓		Mineralische/acrylgebundene Massivplatten/Küchenplatten: Corian®, Noblan®, Hi-Macs®, Staron®, Rausolid®, Varicor®	Mineral/acrylic bound solid boards/kitchen worktops: Corian®, Noblan®, Hi-Macs®, Staron®, Rausolid®, Varicor®
✓		Spanplatten, Hartfaserplatten, Platten ohne Belag LDF, MDF, HDF	Chipboard, hard fibre board, boards without laminate LDF, MDF, HDF
✓		Spanplatten, Hartfaserplatten Kunststoff beschichtet/furniert, MDF, HDF	Chipboard, hard fibre board, plastic-coated/veneered, MDF, HDF

ANWENDUNG · APPLICATION

Durch DP (Polykristalliner Diamant) Zähne ideal für Zuschnitte sowie Formatschnitte in extrem abrasive, zu hohen Schneidenverschleiß führenden Materialien wie: Corian, Trespa, Laminat, MDF, Gips- und Zementgebundene Platten (Faserzement), Steinwollplatten, Heraklith, Eternit.

Blätter mit niedriger Zähnezahl wie: 160mm mit 4 Zähnen, 190mm mit 6 Zähnen, 230mm mit 6 Zähnen, 250mm mit 6 Zähnen und 300mm mit 8 Zähnen, sind speziell geeignet für Gips- und Zementgebundene Platten. (Faserzement)

Speziell hervorragend ebenfalls für Duroplaste wie: Glasfaserverstärkte sowie Kohlefaserverstärkte Kunststoffe (GFK, CFK), Carbon, Aramidfaserkunststoffe (AFK) HP, HPL, PUR.

Niedere Zahnreihe für Zuschnitte, höhere Zahnreihe für Formatschnitte. Achtung: Keine Fertigschnitt-Blatt (DP-Bestückung = 4mm). Fertigschnitt-Blätter siehe Art. 11.1370 Seite 576

Due to DP (Polycrystalline Diamond) teeth excellent for sizing, formatting, cross cuts in extreme abrasive, heavy machining and abrading materials such as: Corian, Trespa, laminates, MDF, gypsum and cement-bonded boards (fiber cement), Rockwool boards, Heraklith products, Eternit.

Circular saws with the lowest number of teeth as: 160mm with 4 teeth, 190mm with 6 teeth, 230mm with 6 teeth, 250mm with 6 teeth und 300mm with 8 teeth, are specially designed for gypsum and cement-bonded panels (fiber cement).

Also excellent for Duroplastic materials such as: Glas fibre plastic (GFK), Carbon fibre plastic (CFK), Carbon, Aramid fibre plastic (AFK), HP, HPL, PUR.







Lower tooth row for sizing, higher tooth row for format cuts. Attention: no finishing cut blade (DP-Tip height = 4mm). Finishing cut-blades see Art. 11.3070 page 576



Video



Art.
100
101
102

Art.							€
111350.160.005	● 160	2,2/1,6	20/16	4 FL	2-6-32,5	✓	39,70
111350.160.010	● 160	2,2/1,6	20/16	8 FL	2-6-32,5	✓	78,05
111350.160.020	● 160	2,2/1,6	20/16	30 FL	2-6-32,5	✓	231,50
111350.180.010	● 180	2,2/1,6	30/20	8 FL	2-7-42	✓	78,55
111350.190.005	● 190	2,2/1,6	30/20	6 FL	2-7-42	✓	54,90
111350.190.010	● 190	2,2/1,6	30/20	8 FL	2-7-42	✓	79,10
111350.190.020	● 190	2,2/1,6	30/20	30 FL	2-7-42	✓	249,60
111350.210.010	● 210	2,2/1,6	30	12 FL	UNI	✓	111,10
111350.210.020	● 210	2,2/1,6	30	30 FL	UNI	✓	279,05
111350.216.010	● 216	2,2/1,6	30	12 FL	UNI	✓	111,10
111350.216.020	● 216	2,2/1,6	30	30 FL	UNI	✓	279,05
111350.230.005	● 230	2,4/1,8	30	6 FL	UNI	✓	64,35
111350.230.010	● 230	2,4/1,8	30	15 FL	UNI	✓	148,30
111350.230.020	● 230	2,4/1,8	30	30 FL	UNI	✓	279,05
111350.250.005	● 250	2,4/1,8	30	6 FL	UNI	✓	65,90
111350.250.010	● 250	2,4/1,8	30	16 FL	UNI	✓	164,85
111350.250.020	● 250	2,4/1,8	30	40 FL	UNI	✓	375,65
111350.300.005	● 300	2,2/1,6	30	8 FL	UNI	✓	88,20
111350.300.010	▲ 300	2,2/1,6	30	30 FL	UNI	✓	315,00
111350.300.020	● 300	2,6/2,0	30	36 FL	UNI	✓	360,15
111350.300.030	● 300	2,6/2,0	30	48 FL	UNI	✓	468,15
111350.300.040	● 300	2,6/2,0	30	60 FL	UNI	✓	609,20
111350.350.010	● 350	2,8/2,2	30	60 FL	UNI	✓	649,50

▲ = Auslaufartikel / Discontinued · UNI = 2-7-42 + 2-9-46,40 + 2-10-60



✓ Geeignet für · Suitable for
Siehe Seite 604-607 · See page 604-607



Echte Hochkaräter für abrasive Werkstoffe.

KARNASCH DIAMANT-SÄGEBLÄTTER

True high-caliber for abrasive materials.

KARNASCH DIAMOND BLADES

POWER.
PRECISION.
PERFORMANCE.

Karnasch®
PROFESSIONAL TOOLS

- 1 
- 2 
- 3 
- 4 
- 5 
- 6 
- 7 
- 8 
- 9 
- 10 

Art.
100
101
102

Karnasch® DP-BESTÜCKTE KREISSÄGEBLÄTTER DP TIPPED CIRCULAR SAW BLADES

Art. **11.1370**

GOLD-STAR LINE 

Diamant · Formatieren · Fertigschnitt · Harte Kunststoffe · Abrasive Werkstoffe
Diamond · Panel-sizing · Finishing cut · Hard plastics · Abrasive Materials

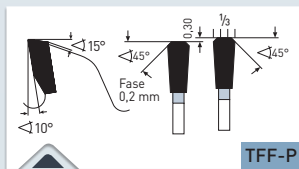





- > Trapez-Flachzahn (mit beidseitiger Schutzfase)
- > Triple-chip/flat tooth (with protective chamfer on both sides)

MASCHINE · MACHINE

Für Formatkreissägen, Plattensägen, Tischkreissägen

For sizing saws, panel saws, bench saws

✓ OPTIMAL · OPTIMAL ✓ GUT · GOOD ✓ MÖGLICH · POSSIBLE

✓		Kunststoffe, Plexiglas, Duro- und Thermoplaste	Plastics, plexiglass, acrylics, duro- and thermoplastics
✓		Spanplatten, Hartfaserplatten Kunststoff beschichtet/furniert, MDF, HDF	Chipboard, hard fibre board, plastic-coated/veneered, MDF, HDF
✓		Mineralische/acrylgebundene Massivplatten/Küchenplatten: Corian®, Noblan®, Hi-Macs®, Staron®, Rausolid®, Varicor®	Mineral/acrylic bound solid boards/kitchen worktops: Corian®, Noblan®, Hi-Macs®, Staron®, Rausolid®, Varicor®
✓		HPL-Duroplastische Schichtstoff- platten/Fassadenplatten: Trespa®, Resopal®, Duropal®, Formica®, Kronospan®, Decodur®	HPL High-Pressure-Laminate solid boards/façade panels: Trespa®, Resopal®, Duropal®, Formica®, Kronospan®, Decodur®
✓		Gips-Zement-Steinwollplatten, Eternit, GFK, CFK, HPL, Mineral- werkstoffe	Gypsum/Cement fibre boards, Rockwool, Eternit, GRP, CFK, HPL, Mineral material

ANWENDUNG · APPLICATION

Durch DP (Polykristalliner Diamant) Zähne extrem lange Standzeiten gegenüber Hartmetall-bestückte Kreissägeblätter. Ideal für Zuschnitte sowie Formatschnitte in extrem abrasive, zu hohen Schneidenschleiß führenden Materialien wie: Corian, Trespa, Laminat, MDF, Gips- und Zementgebundene Platten, Steinwollplatten, Heraklith, Eternit.

Speziell hervorragend ebenfalls für Duroplaste wie: Glasfaserverstärkte sowie Kohlefaserverstärkte Kunststoffe (GFK, CFK), Carbon, Aramidfaserkunststoffe (AFK) HP, HPL, PUR.

Weiterhin hervorragend für Fertigschnitte in thermoplastische Vollplatten (Acrylglas, PMMA, Polyäthylen, Polyamid usw.) sowie duroplastische Vollplatten (Schichtstoffe, HPL, Hartpapier, Trespa, Resopal, Multiplex). Weiterhin für Polymergebundene Kunststoffe, Mineralwerkstoffe wie Corian, Noblan, Hi-Macs, Staron, Rausolid usw.

Hervorragend ebenfalls für Fertigschnitte in beidseitig Kunststoffbeschichteten Plattenwerkstoffe, vorzugsweise in Verbindung mit Vorritzer. Ideal auch zum schneiden von Kunststoff-Profilen.

Due to DP (Polycrystalline Diamond) teeth extremely long tool life compared to carbide tipped circular saws. Excellent for sizing, formatting, cross cuts in extreme abrasive, heavy machining and abrading materials such as: Corian, Trespa, laminates, MDF, gypsum and cement-bonded boards, Rockwool boards, Heraklith products, Eternit.

Also excellent for Duroplastic materials such as: Glas fibre plastic (GFK), Carbon fibre plastic (CFK), Carbon, Aramid fibre plastic (AFK), HP, HPL, PUR.

For finishing cuts in solid thermoplastic boards (PMMA, acrylic glass, polyethylene, polyamide etc.) and solid duroplastic boards (HPL-high-pressure-laminate, HP-Hardpaper, phenolic resin bonded paper, phenolic laminated cotton sheets, Trespa, Resopal, Multiplex). Also for polymer-bound plastics, mineral materials such as Corian, Noblan, Hi-Macs, Staron, Rausolid etc.

Excellent also for finishing cuts in double-side plastic coated boards, preferably in combination with coring sawblades. Ideal also for cutting plastic profiles.

- 1 
- 2 
- 3 
- 4 
- 5 
- 6 
- 7 
- 8 
- 9 
- 10 





Art.
100
101
102

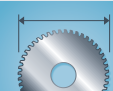

Diamant · Formatieren · Fertigschnitt · Harte Kunststoffe · Abrasive Werkstoffe
Diamond · Panel-sizing · Finishing cut · Hard plastics · Abrasive Materials

Art. **11.1370**

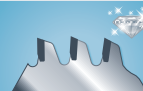
GOLD-STAR LINE 

Art.							DP-Bestückungshöhe DP-Tip hight	€
111370.250.010	● 250	3,2/2,2	30	60 TFF-P	UNI	✓	5 mm	886,65
111370.250.020	● 250	3,2/2,2	30	80 TFF-P	UNI	✓	5 mm	1162,55
111370.300.010	● 300	3,2/2,2	30	72 TFF-P	UNI	✓	5 mm	1278,80
111370.300.020	● 300	3,2/2,2	30	96 TFF-P	UNI	✓	4 mm	1384,20
111370.303.010	● 303	3,2/2,2	30	60 TFF-P	UNI	✓	5 mm	934,70
111370.303.020	● 303	3,2/2,2	30	72 TFF-P	UNI	✓	5 mm	1278,80
111370.303.030	● 303	3,2/2,2	30	96 TFF-P	UNI	✓	4 mm	1384,20
111370.350.010	● 350	3,2/2,2	30	84 TFF-P	UNI	✓	5 mm	1333,05
111370.350.020	● 350	3,2/2,2	30	108 TFF-P	UNI	✓	4 mm	1520,60

UNI = 2-7-42 + 2-9-46,40 + 2-10-60

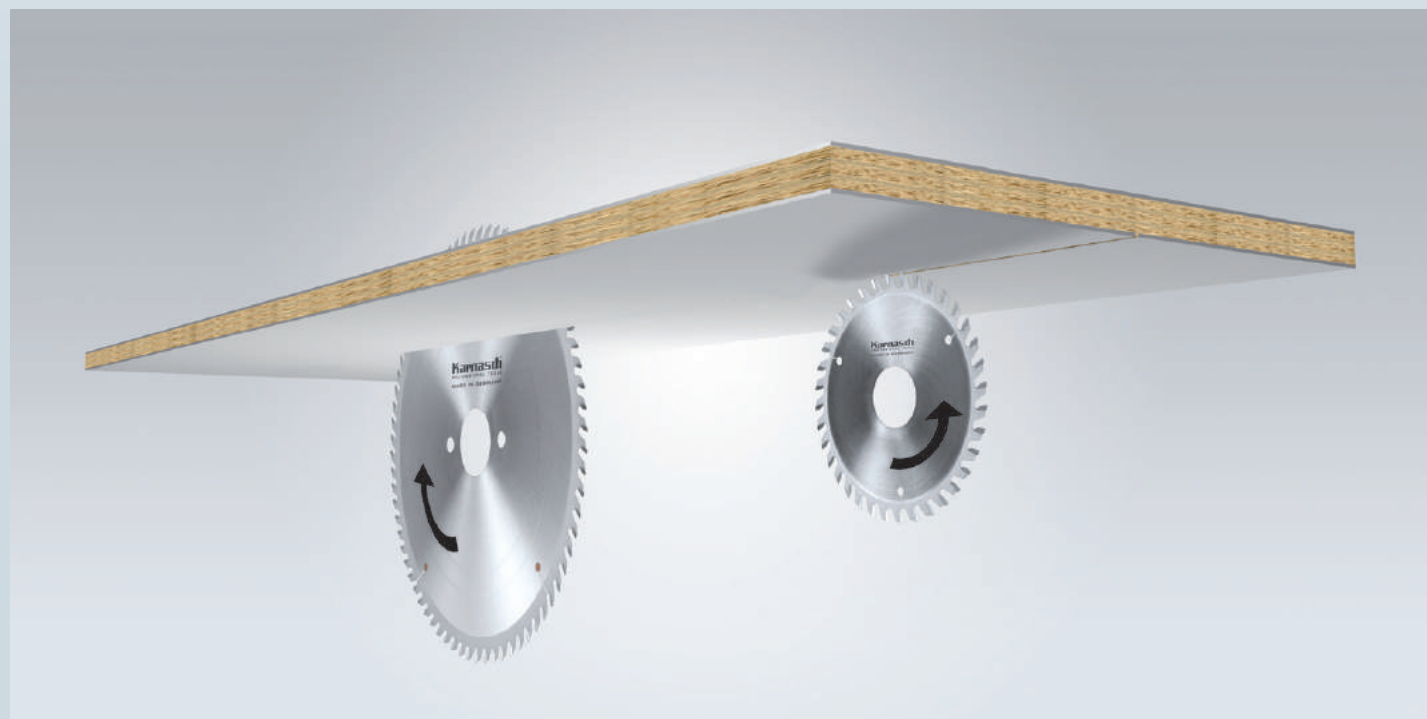

Bei Kunststoff/Melamin beschichtete Plattenwerkstoffe Vorritzen empfohlen. Ritzer siehe Seite 615/669. Sägen von beschichteten/furnierten Plattenwerkstoffe ohne Vorritzer siehe Seite 573, 637, 639, 641, 643, 645

For plastic coated/melamine boards scoring recommended. Scorer see page 615/669. Cutting of coated/veneered boards without scorer see page 573, 637, 639, 641, 643, 645

1



2



3



4



5



6



7



8



9



10



Art.
100
101
102

Karnasch® HARTMETALL-BESTÜCKTE KREISSÄGEBLÄTTER CARBIDE TIPPED CIRCULAR SAW BLADES

Art. **11.1430**

GOLD-STAR LINE 

Harte Kunststoffe · Abrasive Werkstoffe · Fertigschnitt/Dünnschnitt
Hard plastics · Abrasive materials · Finishing-cut / Thin-cut

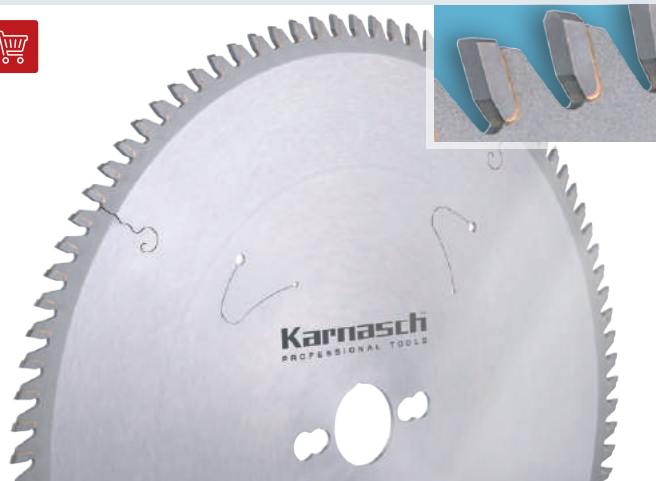

✓ OPTIMAL · OPTIMAL ✓ GUT · GOOD ✓ MÖGLICH · POSSIBLE

✓		Kunststoffe, Plexiglas, Duro- und Thermoplaste	Plastics, plexiglass, acrylics, duro- and thermoplastics
✓		Mineralische/acrylgebundene Massivplatten/Küchenplatten: Corian®, Noblan®, Hi-Macs®, Staron®, Rausolid®, Varicor®	Mineral/acrylic bound solid boards/kitchen worktops: Corian®, Noblan®, Hi-Macs®, Staron®, Rausolid®, Varicor®
✓		HPL-Duroplastische Schichtstoffplatten/Fassadenplatten: Trespa®, Resopal®, Duropal®, Formica®, Kronospan®, Decodur®	HPL High-Pressure-Laminate solid boards/façade panels: Trespa®, Resopal®, Duropal®, Formica®, Kronospan®, Decodur®
✓		Gips-Zement-Steinwollplatten, Eternit, GFK, CFK, HPL, Mineralwerkstoffe	Gypsum/Cement fibre boards, Rockwool, Eternit, GRP, CFK, HPL, Mineral material
✓		Dünnbleche, Sandwich Material, Verbundstoffe	Thin iron sheets, sandwich material, composites
✓		Dünne Profile aus Ne-Metall wie Alu, Messing, Kupfer	Thin profiles made of non ferrous materials like alu, copper, brass

1 

2 

3 

4 

5 

6 

7 

8 

9 

10 

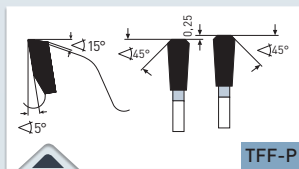

> Trapez Flach Fase Positiv
> Triple-chip/triple-chip teeth

MASCHINE · MACHINE

Für Handkreissägen, Tauchsägen, Tisch- und Formatkreissägen, Plattenaufteilsägen, Kappsägen, Akkusägen

For portable circular saws, bench- and sizing saws, panel sizing saws, cross-cut saws, cordless saws.

ANWENDUNG · APPLICATION

Durch spezielles Hartmetall/Zahnform ideal für Fertigschnitte in dünnen Platten und Profilmaterial aus harten Kunststoffen (Thermoplaste) wie: PVC, PE, PA, ABS, PS, POM PC, PMMA (Acrylglas). z.B. Hohlkammerplatten aus PMMA (Acrylglas).

Ebenfalls gut bei abrasiven, zu hohen Schneidenverschleiß führenden Materialien wie: GFK, CFK, Zementplatten, Gipsfaserplatten, Eternit.

Ebenfalls exzellent geeignet für Sandwichmaterialien mit dünnen Deckschichten. Maximale Deckschichtdicke Nicht-Eisen Metalle / Kunststoffe = 1,0 mm
Maximale Deckschichtdicke Eisenblech = 0,3 mm
Hervorragend auch für dünne Profile bis 1 mm Wandstärke aus Nicht-Eisen-Metalle, wie Alu, Kupfer, Messing.

Durch dünne Schnittbreite wenig Kraftaufwand und Verschnitt. Daher auch ideal für Akku-Maschinen.

Due to special carbide / tooth geometry excellent for finishing cuts in thin plates and profiles made of hard plastics (thermoplastics) such as: PVC, PE, PA, ABS, PS, POM PC, PMMA e.g. hollow section boards of PMMA (acrylic glass).

Also good for abrasive, heavy machining and abrading materials such as: GFK, CFK, fibre cement panels, gypsum, fibre boards, eternit.

Also excellent for sandwich materials with thin layers. Maximum layer thickness for non-ferrous-metals / plastics = 1,0 mm
Maximum layer thickness iron sheet metal = 0,3 mm
Excellent also for thin profiles up to 1 mm thickness made of non-ferrous metal such as aluminum, copper, brass.

Due to thin cutting width little cutting pressure and waste of material. Therefore also ideal for cordless machines.







Art.
100
101
102

Harte Kunststoffe · Abrasive Werkstoffe · Fertigschnitt/Dünnschnitt
Hard plastics · Abrasive materials · Finishing-cut / Thin-cut

Art. **11.1430**

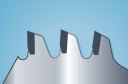
GOLD-STAR LINE 

Art.							€
111430.120.010	● 120	1,8/1,2	20	40 TFF-P	-	-	39,20
111430.160.010	● 160	1,8/1,2	20/16	56 TFF-P	2-6-32	-	47,60
111430.180.010	● 180	1,8/1,2	20/16	60 TFF-P	2-6-32	-	53,10
111430.190.010	● 190	1,8/1,2	30/20	60 TFF-P	2-7-42	-	53,70
111430.200.010	● 200	2,0/1,4	30	64 TFF-P	2-7-42	-	54,80
111430.210.010	● 210	2,0/1,4	30	64 TFF-P	2-7-42	-	55,65
111430.225.010	● 225	2,0/1,4	30	68 TFF-P	2-7-42	-	61,40
111430.230.010	● 230/235 ●	2,0/1,4	30	68 TFF-P	2-7-42	-	62,15
111430.250.010	● 250	2,4/1,8	30	80 TFF-P	UNI	✓	73,55
111430.300.010	● 300	2,4/1,8	30	96 TFF-P	UNI	✓	89,15
111430.350.010	● 350	2,4/1,8	30	108 TFF-P	UNI	✓	103,80
111430.400.010	● 400	3,2/2,5	30	120 TFF-P	UNI	✓	123,25
111430.450.010	● 450	3,5/2,8	30	132 TFF-P	UNI	✓	190,35
111430.500.010	● 500	3,5/2,8	30	144 TFF-P	UNI	✓	245,75

● Gefertigt/Manufactured 232,50 mm · UNI = 2-7-42 + 2-9-46,40 + 2-10-60

1



2



3



4



5



6



7



8



9



10



Art.
100
101
102

Karnasch® HARTMETALL-BESTÜCKTE KREISSÄGEBLÄTTER CARBIDE TIPPED CIRCULAR SAW BLADES

Art. **11.1460**

GOLD-STAR LINE

Formatieren · Fertigschnitt · Harte Kunststoffe · Abrasive Werkstoffe
Panel-sizing · Finishing cut · Hard plastics · Abrasive materials

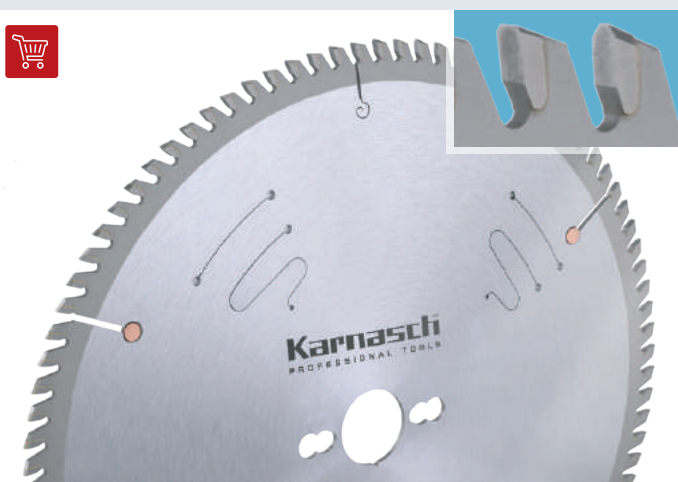

✓ OPTIMAL · OPTIMAL ✓ GUT · GOOD ✓ MÖGLICH · POSSIBLE

✓		Kunststoffe, Plexiglas, Duro- und Thermoplaste	Plastics, plexiglass, acrylics, duro- and thermoplastics
✓		Spanplatten, Hartfaserplatten Kunststoff beschichtet/furniert, MDF, HDF	Chipboard, hard fibre board, plastic-coated/veneered, MDF, HDF
✓		Mineralische/acrylgebundene Massivplatten/Küchenplatten: Corian®, Noblan®, Hi-Macs®, Staron®, Rausolid®, Varicor®	Mineral/acrylic bound solid boards/kitchen worktops: Corian®, Noblan®, Hi-Macs®, Staron®, Rausolid®, Varicor®
✓		HPL-Duroplastische Schichtstoff- platten/Fassadenplatten: Trespa®, Resopal®, Duropal®, Formica®, Kronospan®, Decodur®	HPL High-Pressure-Laminate solid boards/façade panels: Trespa®, Resopal®, Duropal®, Formica®, Kronospan®, Decodur®
✓		Gips-Zement-Steinwollplatten, Eternit, GFK, CFK, HPL, Mineral- werkstoffe	Gypsum/Cement fibre boards, Rockwool, Eternit, GRP, CFK, HPL, Mineral material

ANWENDUNG · APPLICATION

Zum Formatieren von Platten in verschiedenen Dicken, Paketschnitte aus Thermo-
plaste wie: PVC, PE, PA, ABS, PS, POM.

Hervorragend auch zum schneiden von Kunststoffprofilen sowie für Fertigschnitte in
beidseitig Kunststoffbeschichtete Span- und Faserwerkstoffe/Platten vorzugsweise
in Verbindung mit Ritzer.

Durch spezielles Hartmetall auch gut bei abrasiven zu schnellem Schneidenver-
schleiß führenden Verbundstoffen wie faserverstärkte Gipskartonplatten, GFK, CFK.

Ebenfalls ideal für Duroplaste wie HPL Schichtstoff (Trespa, Resopal) und Mineral-
werkstoffe wie Corian, Noblan, Staron usw.

For sizing panels of various thicknesses, cutting stacks made of thermoplastics
such as: PVC, PE, PA, ABS, PS, POM.

Excellent also for cutting plastic profiles and finishing cuts in double-side plastic
coated chip- and hard fibre materials/boards in combination with scoring sawblades.

Due to special carbide teeth also good for cutting abrasive, heavy machining and
abrading materials such as HPL, high-pressure-laminate (Trespa, Resopal) and
mineral materials such as corian, noblan, staron etc.

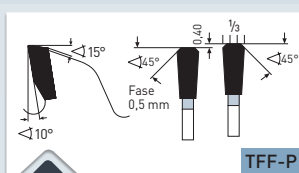

TFF-P

- > Trapez-Flachzahn (Flachzahn mit Fase)
- > Triple-chip/flat tooth (flat tooth with chamfer on both sides)

MASCHINE · MACHINE

Für Formatkreissägen, Plattensägen, Tischkreissägen

For sizing saws, panel saws, bench saws

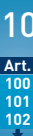





Art.
100
101
102



Formatieren · Fertigschnitt · Harte Kunststoffe · Abrasive Werkstoffe
Panel-sizing · Finishing cut · Hard plastics · Abrasive materials

Art. **11.1460**

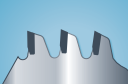
GOLD-STAR LINE 

Art.							€
111460.250.010	• 250	3,2/2,2	30	60 TFF-P	UNI	✓	73,60
111460.250.020	• 250	3,2/2,2	30	80 TFF-P	UNI	✓	92,30
111460.300.010	• 300	3,2/2,2	30	72 TFF-P	UNI	✓	89,80
111460.300.020	• 300	3,2/2,2	30	96 TFF-P	UNI	✓	108,05
111460.303.010	• 303	3,2/2,2	30	60 TFF-P	UNI	✓	78,65
111460.303.020	• 303	3,2/2,2	30	72 TFF-P	UNI	✓	89,80
111460.303.030	• 303	3,2/2,2	30	96 TFF-P	UNI	✓	108,05
111460.350.010	• 350	3,2/2,2	30	84 TFF-P	UNI	✓	106,70
111460.350.020	• 350	3,2/2,2	30	108 TFF-P	UNI	✓	128,95
111460.400.010	• 400	3,5/2,5	30	120 TFF-P	UNI	✓	142,95

UNI = 2-7-42 + 2-9-46,40 + 2-10-60



Bei Kunststoff/Melamin beschichtete Plattenwerkstoffe Vorritzen empfohlen. Ritzer siehe Seite 669. Sägen von beschichteten/furnierten Plattenwerkstoffe ohne Vorritzer siehe Seite 615

For plastic coated/melamine boards scoring recommended. Scorer see page 669. Cutting of coated/veneered boards without scorer see page 615

1



2



3



4



5



6



7



8



9



10



Art.
100
101
102

Plattenaufteilung (Formatieren) großflächig

Panel sizing large-scale

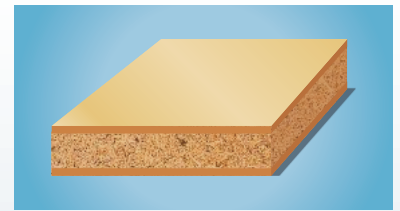

Schnittwertempfehlungen · Recommended cutting values

Werkstoffgruppe Material Group	Werkstoffbeispiele Material examples	Vc (m/s) Schnittgeschwindigkeit Cutting speed	fz (mm/z) Vorschub pro Zahn Feed per tooth
Furnierte Platten · Veneered panels	Multiplex	60–90	0,2
HDF (Hochdichte Faserplatte) · HDF (High density fiber board)	Hartfaserplatte · Beaver board	50–80	0,15
MDF (Mitteldichte Faserplatte) · MDF (medium density fiber board)	Doppelstegplatten · Twin-wall panel	60–80	0,1–0,3
OSB-Platten · OSB-Oriented Strand Board	Verlegeplatten · Particle board	60–80	0,1–0,2
Pressschichtholz · Lumber-core plywood		40–65	0.02–0,06
Spanplatten roh · Chipboard raw		60–80	0,3
Spanplatten Kunststoff Beschichtet · Chipboard plastic coated	Melamin, HPL, CPL	60–80	0,15
Tischlerplatten (Stabplatten, Stäbchenplatten) · Plywood (lumber-core, rod-shaped)		60–80	0,1–0,2
Weichfaserplatten · Softboard		60–100	0,2–0,4
Sperrholz, Lagenholz · Plywood, Iminated layers		50–80	0.05–0,25
Duroplaste · Duroplastics	HPL-Schichtstoffplatten HPL (High-Pressure-Laminate) Trespa®, Resopal®, Wodego®, Duropal®, Formica®, Unilin®, Kronospan®, Homapal®, Decodur®, Abet®	50–70	0,01–0,08
Mineralisch-Acrylgebundene Materialien · Mineral-Acrylic bound materials	Corian®, Noblan®, Hi-Macs®, Staron®, Rausolid®, Varicor®	50–70	0,02–0,04

Drehzahl n (U/min) · Revolution per minute n (rpm)

	1500	2000	2500	2850	3000	4000	4500	5000	5600	6000	8000	9000	10000	12000	18000
80 Ø	6,5	8,5	10,5	12	13	17	19	21	23,5	26	34	38	42	52	76
90 Ø	7	9,5	12	13,5	14	19	21	24	26,5	28	38	42	48	56	84
100 Ø	8	10,5	13	15	16	21	24	26	29	32	42	48	52	54	96
120 Ø	9,5	13	16	18	19	26	28	32	35	38	52	56	64	76	112
125 Ø	10	13,5	16,5	18,5	19,5	27	29	33	36,5	39	54	59	66	78	118
140 Ø	11	15	18	21	22	30	33	36	41	44	60	66	72	88	132
150 Ø	12	15,5	19,5	22,5	23,5	31,5	33,5	39	44	47	63	70,5	78,5	94,5	141,5
160 Ø	13	17	21	24	26	34	38	42	47	52	68	76	84	104	152
180 Ø	14	19	24	27	28	38	42,5	48	53	56	76	85	96	118	170
200 Ø	16	21	26	30	32	42	47	52	58,5	64	84	94	104	128	188
225 Ø	18	24	30	33,5	36	48	58	60	66	72	96	106	120	144	212
250 Ø	20	26	33	37	40	52	59	66	73,5	80	104	118	132	160	236
300 Ø	24	31,5	40	45	48	63	71	80	88	96	126	142	160	192	284
350 Ø	28	36,5	47	52	56	73	88	94	105	112	146	166	188	224	332
400 Ø	32	42	54	60	64	84	94	108	117	128	168	188	216	256	376
450 Ø	35,5	47	59	67,5	70,5	94,5	106	118	132	141,6	188	211	236	283	424
500 Ø	40	53	67	74,5	80	106	118	134	146,5	160	212	236	268	320	472

Schnittgeschwindigkeit in m/s · Cutting speed in m/s

1 Platten · Panels

2 Sicherheitsgrenze · Safety limits

Festlegung der Schnittgeschwindigkeit Vc
 Determination of cutting speed Vc

$$Vc (m/s) = \frac{D \cdot \pi \cdot n}{60 \cdot 1000}$$

Festlegung der Vorschubgeschwindigkeit Vf
 Determination of feed rate Vf

$$Vf (m/min) = \frac{fz \cdot n \cdot Z}{1000}$$

Vc (m/s) = Schnittgeschwindigkeit · Cutting speed

Vf (m/min) = Vorschubgeschwindigkeit · Feed rate

fz (mm/z) = Vorschub pro Zahn · Feed per tooth

D (mm) = Sägendurchmesser · Saw blade diameter

n (min⁻¹) = Drehzahl · rpm

Z = Anzahl der Zähne · Number of teeth



Art.
100
101
102

Plattenaufteilung (Formatieren) großflächig

Panel sizing large-scale

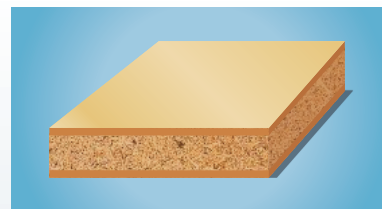

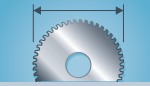
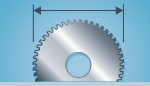
Art. Ø mm	Type	Anwendung · Application	
11.1510 Ø mm 300-450 	Plattenaufteilsägen großflächig	Für Formatschnitte in beschichtete Holzwerkstoffe einzeln und im Paket sowie Duroplaste.	615
	Large-scale panel sizing blades	For panel sizing plastic laminated and foil-coated wood-based material and duroplastics.	
11.1520 Ø mm 125-200 	Konische Ritzer passend für obige Plattenaufteilsägen	Konische Ritzer passend für obige Plattenaufteilsägen	615
	Conical scoring blades suitable for above mentioned panel sizing blades	Conical scoring blades suitable for above mentioned panel sizing blades	

1



2



3



4



5



6



7



8



9



10



Art.
100
101
102

Art. **11.1510**

Plattenaufteilsägen + konische Ritze
Panel sizing saws + conical scoring blades

GOLD-STAR LINE

Art. **11.1520**

GOLD-STAR LINE

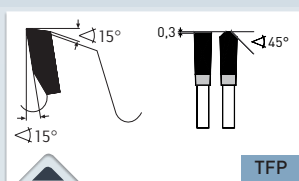

> Trapez Flach Positiv
> Trapezoidal flat top positive

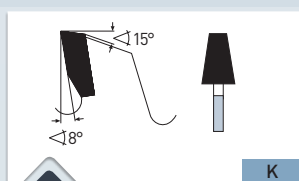

> Konisch Flachzahn
> Flat tooth conical

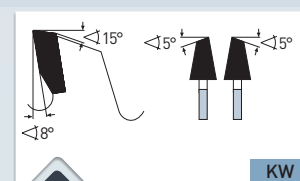

> Konisch-Wechselzahn
> Alternative top bevel conical

MASCHINE · MACHINE

Plattenaufteilanlagen horizontal mit Vorritzaggregat

Panel sizing machine horizontal with scoring aggregate

✓ OPTIMAL · OPTIMAL ✓ GUT · GOOD ✓ MÖGLICH · POSSIBLE

✓		Spanplatten, Hartfaserplatten, Platten ohne Belag LDF, MDF, HDF	Chipboard, hard fibre board, boards without laminate LDF, MDF, HDF
✓		Spanplatten, Hartfaserplatten Kunststoff beschichtet/furniert, MDF, HDF	Chipboard, hard fibre board, plastic-coated/veneered, MDF, HDF
✓		Kunststoffe, Plexiglas, Duro- und Thermoplaste	Plastics, plexiglass, acrylics, duro- and thermoplastics
✓		Mineralische/acrylgebundene Massivplatten/Küchenplatten: Corian®, Noblan®, Hi-Macs®, Staron®, Rausolid®, Varicor®	Mineral/acrylic bound solid boards/kitchen worktops: Corian®, Noblan®, Hi-Macs®, Staron®, Rausolid®, Varicor®
✓		HPL-Duroplastische Schichtstoffplatten/Fassadenplatten: Trespa®, Resopal®, Duropal®, Formica®, Kronospan®, Decodur®	HPL High-Pressure-Laminate solid boards/façade panels: Trespa®, Resopal®, Duropal®, Formica®, Kronospan®, Decodur®
✓		Gips-Zement-Steinwollplatten, Eternit, GFK, CFK, HPL, Mineralwerkstoffe	Gypsum/Cement fibre boards, Rockwool, Eternit, GRP, CFK, HPL, Mineral material

ANWENDUNG · APPLICATION







Für Formatschnitte in beschichtete Holzwerkstoffe einzeln und im Paket, Duroplaste

For panel sizing plastic laminated and foil-coated wood-based material and duroplastics



Video

Plattenaufteilsägen + konische Ritze
Panel sizing saws + conical scoring blades

Art.	Art.	HAUPTSÄGE + PASSENDER RITZER MAIN SAW BLADE + SUITABLE SCORING BLADE							€			
111510.300.010	-	Panhans + Ritzer/Scorer	▲ 300	4,4/3,0	30	60 TFP	2-10-60	✓	188,00			
-	111520.125.010		▲ 125	4,4-5,6/3,4	20	24 KW	-	-	91,45			
111510.320.010	-	SELCO + Ritzer/Scorer	● 320	4,4/3,2	65	60 TFP	2-9-110	✓	205,00			
-	111520.200.010		● 200	4,4-5,2/3,2	65	36 K	2-9-110 + 2-9-100	-	121,10			
111510.350.010	-	Mayer + Ritzer/Scorer	● 350	4,4/3,2	30	72 TFP	2-10-60	✓	224,85			
-	111520.200.020		● 200	4,4-5,2/3,2	30	36 KW	2-9-60	-	118,25			
111510.350.010	-	Panhans + Ritzer/Scorer	● 350	4,4/3,2	30	72 TFP	2-10-60	✓	224,85			
-	111520.200.020		● 200	4,4-5,2/3,2	30	36 KW	2-9-60	-	118,25			
111510.350.010	-	Scheer + Ritzer/Scorer	● 350	4,4/3,2	30	72 TFP	2-10-60	✓	224,85			
-	111520.200.020		● 200	4,4-5,2/3,2	30	36 K	2-9-60	-	118,25			
111510.350.010	-	Schelling + Ritzer/Scorer	● 350	4,4/3,2	30	72 TFP	2-10-60	✓	224,85			
-	111520.200.030		● 200	4,4-5,2/3,2	20	36 K	-	-	118,25			
111510.350.020	-	Holzma + Ritzer/Scorer	● 350	4,4/3,2	60	72 TFP	2-14-100	✓	225,45			
-	111520.180.010		● 180	4,4-5,2/3,2	45	36 K	-	-	123,35			
111510.355.010	-	Homag Espana + Ritzer/scorer	● 355	4,4/3,2	75	72 TFP	-	✓	230,15			
-	111520.180.010		● 180	4,4-5,2/3,2	45	36 K	-	-	123,35			
111510.380.010	-	Holzma + Ritzer/Scorer	● 380	4,8/3,5	60	72 TFP	2-14-100	✓	252,10			
-	111520.180.020		● 180	4,8-5,6/3,5	45	36 K	-	-	123,35			
111510.380.020	-	Holzma + Ritzer/Scorer	● 380	4,4/3,2	60	72 TFP	2-14-100	✓	239,60			
-	111520.180.010		● 180	4,4-5,2/3,2	45	36 K	-	-	123,35			
111510.450.010	-	Holzma + Ritzer/Scorer	● 450	4,8/3,5	60	72 TFP	2-14-125	✓	278,55			
-	111520.180.020		● 180	4,8-5,6/3,5	45	36 K	-	-	123,35			
-	111520.125.020	Altendorf, Martin + Ritzer/Scorer	Siehe/See Art. 11.1470 Seite/Page 635, Siehe/See Art. 11.1370, Seite/Page 627, Siehe/See Art. 11.1460, Seite/Page 633			125	3,1-4,3/2,8	22/20	24 KW	-	-	91,45

Weitere Abmessungen auf Anfrage
Other dimensions are available on request

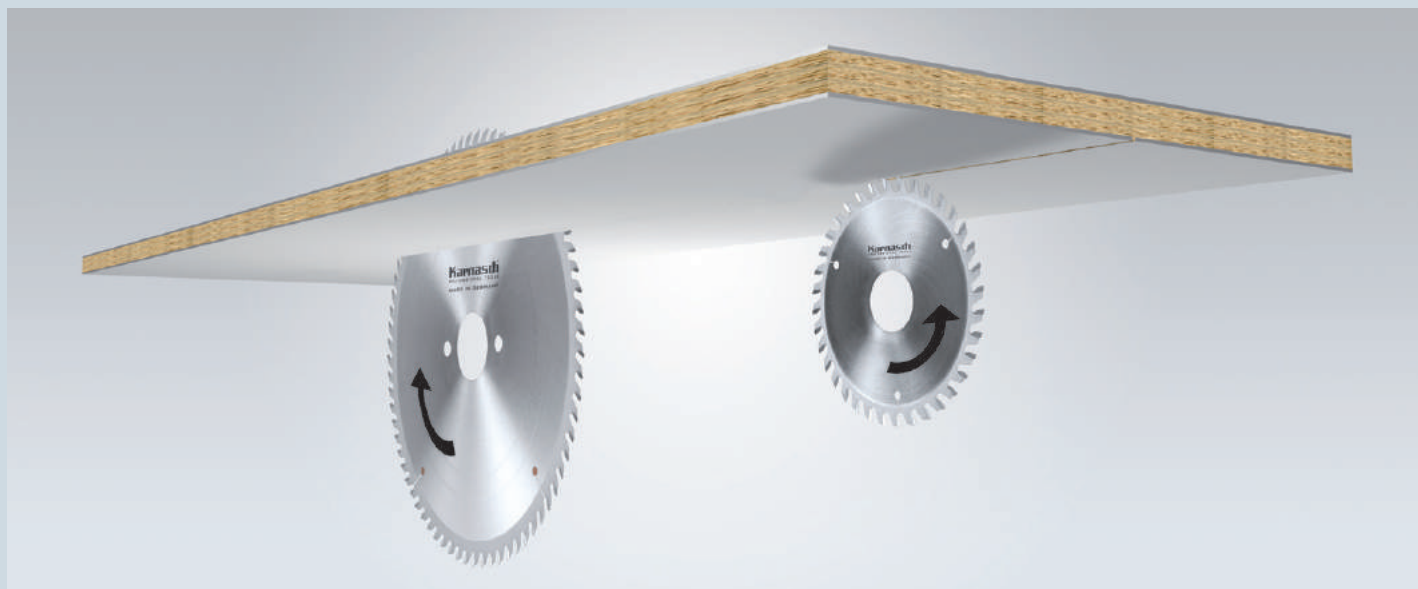

Bei Kunststoff/Melamin beschichtete Plattenwerkstoffe Vorritzen empfohlen.
Ritzer siehe Seite 669. Sägen von beschichteten/furnierten Plattenwerkstoffe
ohne Vorritzer siehe Seite 573

For plastic coated/melamine boards scoring recommended. Scorer see
page 669. Cutting of coated/veneered boards without scorer see page 573

1



2



3



4



5



6



7



8



9



10



Art.
100
101
102

Formatieren

Panel sizing

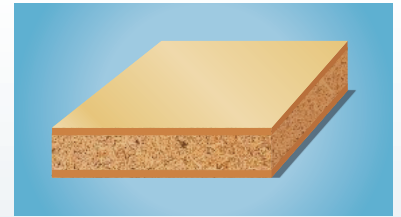

Schnittwertempfehlungen · Recommended cutting values

Werkstoffgruppe Material Group	Werkstoffbeispiele Material examples	V _c (m/s) Schnittgeschwindigkeit Cutting speed	f _z (mm/z) Vorschub pro Zahn Feed per tooth
Furnierte Platten · Veneered panels	Multiplex	60–90	0,2
HDF (Hochdichte Faserplatte) • HDF (High density fiber board)	Hartfaserplatte · Beaver board	50–80	0,15
MDF (Mitteldichte Faserplatte) • MDF (medium density fiber board)	Doppelstegplatten · Twin-wall panel	60–80	0,1–0,3
OSB-Platten · OSB-Oriented Strand Board	Verlegeplatten · Particle board	60–80	0,1–0,2
Pressschichtholz · Lumber-core plywood		40–65	0.02–0.06
Spanplatten roh · Chipboard raw		60–80	0,3
Spanplatten Kunststoff Beschichtet • Chipboard plastic coated	Melamin, HPL, CPL	60–80	0,15
Tischlerplatten (Stabplatten, Stäbchenplatten) • Plywood (lumber-core, rod-shaped)		60–80	0,1–0,2
Weichfaserplatten · Softboard		60–100	0,2–0,4
Sperrholz, Lagenholz • Plywood, lminated layers		50–80	0.05–0,25
Duroplaste · Duroplastics	HPL-Schichtstoffplatten (Trespa®, Resopal®, Wodego®, Duropal®, Formica®, Unilin®, Kronospan®, Homapal®, Decodur®, Abet®) PUR Polyurethan, Melamin, HP Hartpapier	50–70	0,01–0,08
	HPL (High-Pressure-Laminate) (Trespa®, Resopal®, Wodego®, Duropal®, Formica®, Unilin®, Kronospan®, Homapal®, Decodur®, Abet®) PUR Polyurethan, Melamin, HP Hardpaper		
	Glasfaserverstärkte und Kohlefaserverstärkte Kunststoffe GFK/CFK Aramidfaserkunststoffe AFK (Kevlar, Nomex, Carbolan, Rigitor, Durostone)	20–50	0,01–0,03
	Glass fibre and carbon fibre reinforced plastic GFK/CFK Aramid fibre plastik AFK (Kevlar, Nomex, Carbolan, Rigitor, Durostone)		
Mineralisch-Acrylgebundene Materialien z.B. Küchenplatten/Waschbecken • Mineral-Acrylic bound materials e.g. kitchen worktops/sink	Corian®, Noblan®, Hi-Macs®, Staron®, Rausolid®, Varicor®	50–70	0,02–0,04

- 1
- 2
- 3
- 4
- 5
- 6
- 7
- 8
- 9
- 10

Art.
100
101
102

Formatieren Panel sizing

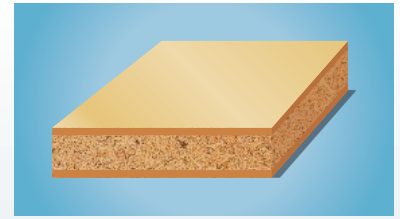

Drehzahl **n** (U/min) • Revolution per minute **n** (rpm)

	1500	2000	2500	2850	3000	4000	4500	5000	5600	6000	8000	9000	10000	12000	18000
80 Ø	6,5	8,5	10,5	12	13	17	19	21	23,5	26	34	38	42	52	76
90 Ø	7	9,5	12	13,5	14	19	21	24	26,5	28	38	42	48	56	84
100 Ø	8	10,5	13	15	16	21	24	26	29	32	42	48	52	54	96
120 Ø	9,5	13	16	18	19	26	28	32	35	38	52	56	64	76	112
125 Ø	10	13,5	16,5	18,5	19,5	27	29	33	36,5	39	54	59	66	78	118
140 Ø	11	15	18	21	22	30	33	36	41	44	60	66	72	88	132
150 Ø	12	15,5	19,5	22,5	23,5	31,5	33,5	39	44	47	63	70,5	78,5	94,5	141,5
160 Ø	13	17	21	24	26	34	38	42	47	52	68	76	84	104	152
180 Ø	14	19	24	27	28	38	42,5	48	53	56	76	85	96	118	170
200 Ø	16	21	26	30	32	42	47	52	58,5	64	84	94	104	128	188
225 Ø	18	24	30	33,5	36	48	58	60	66	72	96	106	120	144	212
250 Ø	20	26	33	37	40	52	59	66	73,5	80	104	118	132	160	236
300 Ø	24	31,5	40	45	48	63	71	80	88	96	126	142	160	192	284
350 Ø	28	36,5	47	52	56	73	88	94	105	112	146	166	188	224	332
400 Ø	32	42	54	60	64	84	94	108	117	128	168	188	216	256	376
450 Ø	35,5	47	59	67,5	70,5	94,5	106	118	132	141,6	188	211	236	283	424
500 Ø	40	53	67	74,5	80	106	118	134	146,5	160	212	236	268	320	472

Schnittgeschwindigkeit in m/s · Cutting speed in m/s

1 Platten · Panels

2 Sicherheitsgrenze · Safety limits

Festlegung der Schnittgeschwindigkeit Vc
Determination of cutting speed Vc

$$Vc (m/s) = \frac{D \cdot \pi \cdot n}{60 \cdot 1000}$$

Festlegung der Vorschubgeschwindigkeit Vf
Determination of feed rate Vf

$$Vf (m/min) = \frac{fz \cdot n \cdot Z}{1000}$$

Vc (m/s) = Schnittgeschwindigkeit · Cutting speed

Vf (m/min) = Vorschubgeschwindigkeit · Feed rate

fz (mm/z) = Vorschub pro Zahn · Feed per tooth

D (mm) = Sägedurchmesser · Saw blade diameter

n (min⁻¹) = Drehzahl · rpm

Z = Anzahl der Zähne · Number of teeth

1



2



3



4



5



6



7



8



9



10



Art.
100
101
102

Formatieren

Panel sizing

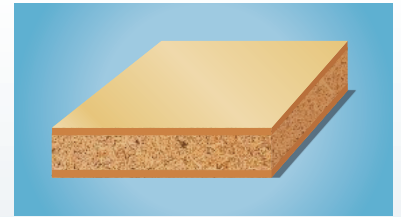

Art. Ø mm	Type	Anwendung · Application	
11.1300 Ø mm 150-800 	Formatieren Universal + Hundegger · Wechselzahn	Gute bis sehr gute Schnittqualität in alle Holzwerkstoffe, Massivholz längs und quer, 1- und 2-seitig Kunststoff/Furnier beschichtete Platten, Leisten, Furniere, Kunststoffe.	623
	Panel sizing Universal + Hundegger · Alternate top bevel tooth	Good to very good cutting quality in all wooden materials, solid wood along and across the grain, panels and boards 1- and 2 sided plastic coated/veneered, strips and veneer, plastics.	
11.1320 Ø mm 200-500 	Formatieren Universal Plus · Wechselzahn + Achswinkel	Hervorragende und ausrissfreie Schnittqualität in alle Holzwerkstoffe, Massivholz quer, 1- und 2-seitig Kunststoff/Furnier beschichtete Platten, Leisten, Folien, Furniere, Kunststoffe (Thermoplast)	625
	Panel sizing Universal Plus · Alternate Top Bevel tooth + Axial-Angle	Excellent, tear-free/splinter-free finishing-cut quality in all wooden materials, solid wood across the grain, panels and boards 1- and 2 sided plastic/veneer coated, strips, veneer, foils, plastics (Thermoplastics)	
11.1370  Ø mm 250-350 	Diamant · Formatieren · Fertigschnitt · Harte Kunststoffe · Abrasive Materialien	Durch DP (Polykristalliner Diamant) Zähne extrem lange Standzeit gegenüber Hartmetall-Bestückte Sägen. Ideal für Zuschnitte/ Formatschnitte in abrasive, zu schnellen Schneidenschleiß führenden Materialien.	627
	Diamond · Panel-sizing · Finishing-cut · Hard Plastics · Abrasive materials	Due to DP (polycrystalline Diamond) teeth extremely long tool life compared to carbide tipped saws. Excellent for sizing, cross cuts in heavy machining and abrading materials.	
11.1425 Ø mm 120-500 	Formatieren Universal · Wechselzahn · Dünnschnitt	Gute bis sehr gute Schnittqualität in alle Holzwerkstoffe, Massivholz längs und quer, 1- und 2-seitig Kunststoff/ Furnier beschichtete Platten, Kunststoffprofile und Platten. Durch dünne Schnittbreite ideal auch für Akkumaschinen und für teure Edelhölzer, Furniere, Leisten da wenig Verschleiß und Schnittdruck/Akkuverbrauch.	629
	Panel sizing Universal · Alternate Top Bevel tooth · Thin-Cut	Good to very good cutting quality in all wooden materials, solid wood along and across the grain, panels and boards 1- and 2 sided plastic coated/veneered, plastic profiles and boards. Due to thin-cut also ideal for battery machines and for cutting expensive precious wood, veneer, strips because of less waste/battery consumption.	



Art.
100
101
102

Formatieren

Panel sizing

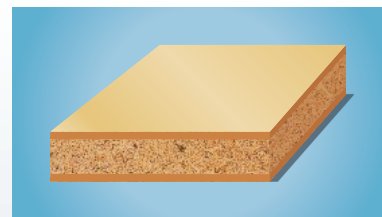

Art. Ø mm	Type	Anwendung · Application	
11.1430 Ø mm 120-500 	Formatieren · Harte Kunststoffe · Abrasive Werkstoffe · Fertigschnitt/Dünnschnitt	Für Fertigschnitte in dünne Platten-Profil-Leisten aus harten/abrasiven Kunststoffen, GFK, CFK, HPL z.B. Trespa®, Mineralwerkstoffe z.B. Corian®, PMMA, Acrylglas (Plexiglas), Eternit, Gips-Zementfaserplatten, Sandwichmaterialien	631
	Panel-sizing · Hard plastics · Abrasive materials · Thin-Cut/Finishing-Cut	For finishing cuts in thin boards-profiles-strips of hard/abrasive plastics, GFK, CFK, HPL e.g. Trespa®, mineral material e.g. Corian®, PMMA (Acrylglas-Plexiglas), Eternit®, Fibre cement/Gypsum fibre boards, Sandwichmaterials.	
11.1460 Ø mm 250-400 	Formatieren · Harte + Abrasive Plattenmaterialien · Trapez-Trapezzahn	Zum Formatieren von 2-seitig Kunststoff beschichtet/furnierte Platten in verschiedenen Dicken. Hervorragend auch für harten/abrasiven Kunststoffen, GFK, CFK, HPL z.B. Trespa®, Mineralwerkstoffe z.B. Corian®, PMMA, Acrylglas (Plexiglas), Eternit, Gips-Zementfaserplatten, Sandwichmaterialien	633
	Panel-sizing · Hard + Abrasive Panel Materials · Triple-chip/Triple-Chip tooth	For sizing 2 sided panels and boards plastic coated/veneered in various thicknesses. Excellent also for hard/abrasive plastics, GFK, CFK, HPL e.g. Trespa®, mineral material e.g. Corian®, PMMA (Acrylglas-Plexiglas), Eternit®, Fibre cement/Gypsum fibre boards, Sandwichmaterials.	
11.1470 Ø mm 220-400 	Formatieren Universal · Trapez-Flachzahn	Universalblatt zum Formatieren von 2-seitig Kunststoff beschichtet/furnierte Platten in verschiedenen Dicken. Gut auch für harten/abrasiven Kunststoffen, GFK, CFK, HPL z.B. Trespa®, Mineralwerkstoffe z.B. Corian®, PMMA, Acrylglas (Plexiglas), Eternit, Gips-Zementfaserplatten, Sandwichmaterialien.	635
	Panel-sizing Universal · Triple-Chip/Flat tooth	Universal blade for sizing 2 sided panels and boards plastic coated/veneered in various thicknesses. Excellent also for hard/abrasive plastics, GFK, CFK, HPL e.g. Trespa®, mineral material e.g. Corian®, PMMA (Acrylglas-Plexiglas), Eternit®, Fibre cement/Gypsum fibre boards, Sandwichmaterials.	
11.1600 Ø mm 160-400 	Formatieren · Hohlzahn · Dach-Flach Positiv	Formatieren von 1+2-seitig Kunststoff beschichtet/furnierte Spanplatten/Möbelplatten in verschiedenen Dicken. Auch ohne Vorritzer gute Unterkante.	637
	Panel-sizing · Hollow tooth · Inverted V / Flat tooth positive	Panel-sizing 1+2 sided plastic coated/veneered chipboards/furniture boards in various thicknesses. Good lower cutting edge quality even without scorer.	

1



2



3



4



5



6



7



8



9



10



Art.
100
101
102

Formatieren

Panel sizing

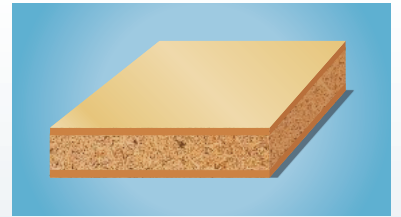

Art. Ø mm	Type	Anwendung · Application	
11.1602 Ø mm 216–350 	Formatieren · Hohlzahn · Dach-Flach Negativ	Formatieren von 1+2-seitig Kunststoff beschichtet/furnierte Spanplatten/Möbelplatten in verschiedenen Dicken. Auch ohne Vorritzer gute Unterkante. Durch negative Zahnform: Ideal auch Kapp- und Gehrungssägen, stabiler und bruchunempfindlicher, besser von Hand zu führen (manueller Vorschub)	639
	Panel-sizing · Hollow tooth · Inverted V/Flat tooth negative	Panel-sizing 1+2 sided plastic coated/veneered chipboards/furniture boards in various thicknesses. Good lower cutting edge quality even without scorer. Because of negative tooth shape: Especially also for chop- and mitre saws, more compact and stable, better guiding by hand (manual feed)	
11.1604 Ø mm 220–350 	Formatieren · Hohlzahn · Trapez-Trapez Positiv	Formatieren von 1+2-seitig Kunststoff beschichtet/furnierte Spanplatten/Möbelplatten in verschiedenen Dicken. Auch ohne Vorritzer gute bis sehr gute Unterkante bei harten Oberflächen welche leicht splintern/ausreißen	641
	Panel-sizing · Hollow tooth · Triple-Chip/Triple Chip Positive	Panel-sizing 1+2 sided plastic coated/veneered chipboards/furniture boards in various thicknesses. Good to very good lower cutting edge quality even without scorer especially for hard surfaces which splinter/break out easily	
11.1610 Ø mm 160–350 	Formatieren · Wechselzahn Extrem 35° · Positiv	Splinterfreie/Ausrissfreie Feinschnitte vom Massivholz quer, Leisten, Furniere, Profile massiv oder beschichtet/furniert. 1+2-seitig Kunststoff beschichtet/furnierte Spanplatten/Möbelplatten in verschiedenen Dicken. Thermopaste. Auch ohne Vorritzer sehr gute Unterkante.	643
	Panel-sizing · Alternate Top Bevel Extreme 35° · Positive	Splinter/tear free finishing cuts in solid wood across the grain, strips, veneer, profiles solid or coated/veneered. 1+2 sided plastic coated/veneered chipboards/furniture boards in various thicknesses. Thermoplastics. Excellent lower cutting edge quality even without scorer.	
11.1615 Ø mm 216–350 	Formatieren · Wechselzahn Extrem 35° · Negativ	Splinterfreie / Ausrissfreie Feinschnitte vom Massivholz quer, Leisten, Furniere, Profile massiv oder beschichtet/furniert. 1+2-seitig Kunststoff beschichtet/furnierte Spanplatten/Möbelplatten in verschiedenen Dicken. Thermopaste. Auch ohne Vorritzer sehr gute Unterkante. Durch negative Zahnform: Ideal auch Kapp- und Gehrungssägen, stabiler und bruchunempfindlicher, besser von Hand zu führen (manueller Vorschub)	645
	Panel-sizing · Alternate Top Bevel Extreme 35° · Negative	Splinter/tear free finishing cuts in solid wood across the grain, strips, veneer, profiles solid or coated/veneered. 1+2 sided plastic coated/veneered chipboards/furniture boards in various thicknesses. Thermoplastics. Excellent lower cutting edge quality even without scorer. Because of negative tooth shape: Especially also for chop-and mitre saws, more compact and stable, better guiding by hand (manual feed).	



Art.
100
101
102

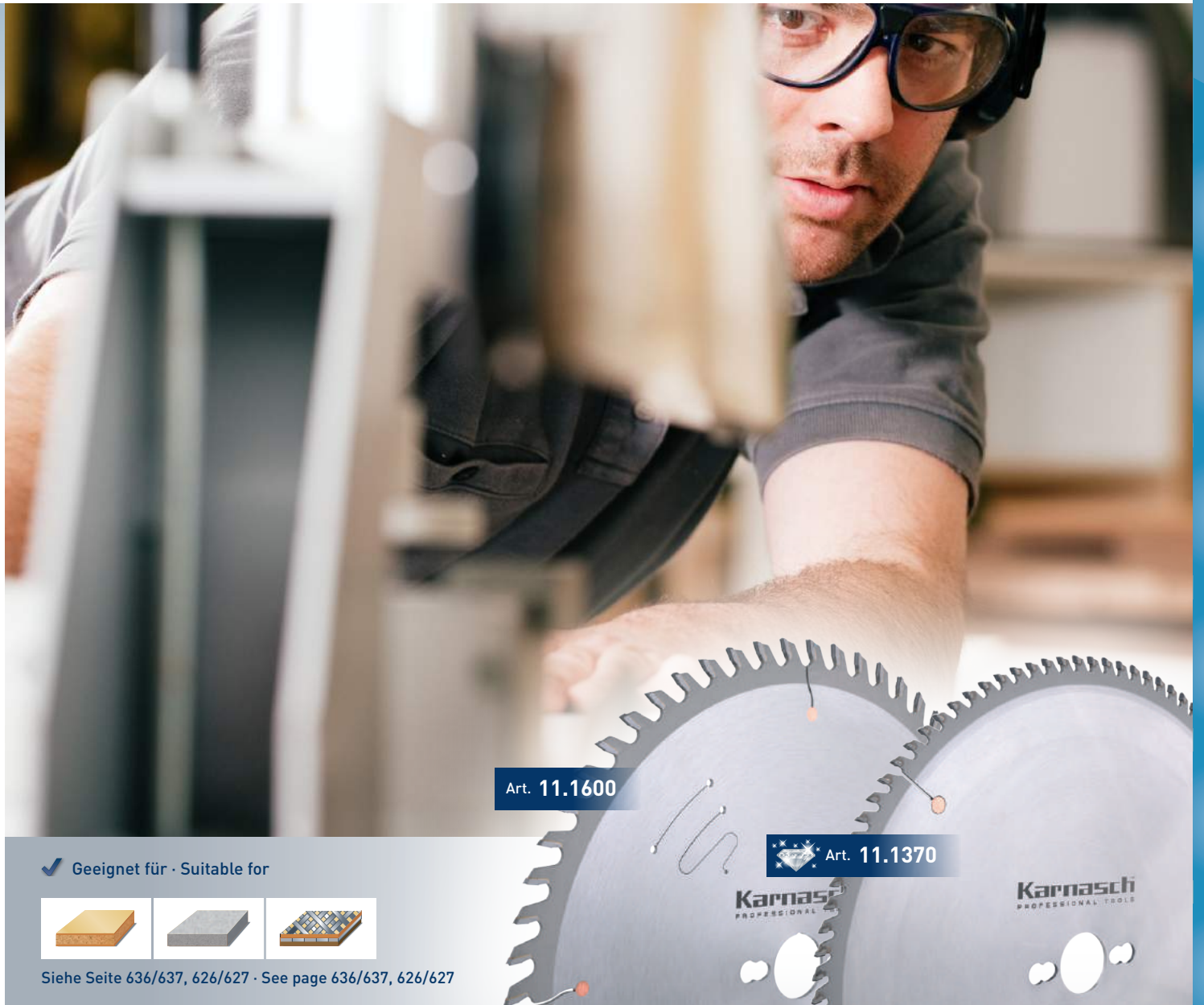

Art. 11.1600

Art. 11.1370

✓ Geeignet für · Suitable for

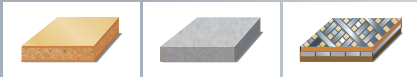

Siehe Seite 636/637, 626/627 · See page 636/637, 626/627

Perfektion beim Formatieren.
Panel-sizing in perfection.

www.karnasch.tools

POWER.
PRECISION.
PERFORMANCE.

Karnasch®
PROFESSIONAL TOOLS

- 1
- 2
- 3
- 4
- 5
- 6
- 7
- 8
- 9
- 10

Art.
100
101
102

Karnasch® HARTMETALL-BESTÜCKTE KREISSÄGEBLÄTTER CARBIDE TIPPED CIRCULAR SAW BLADES

Art. **11.1300**

GOLD-STAR LINE

Formatieren Universal + Hundegger · Wechselzahn

Panel sizing universal + Hundegger · Alternate top bevel tooth

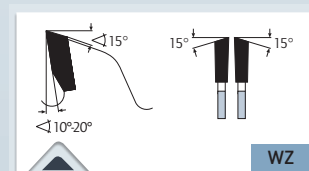

> Wechselzahn
> Alternate top bevel

MASCHINE · MACHINE

Für Tisch- und Formatkreissägen, Kappkreissägen sowie für Hundegger Abbundanlagen.

For bench and panel sizing saws, cross cut saws, Hundegger trimming machines.

✓ OPTIMAL · OPTIMAL ✓ GUT · GOOD ✓ MÖGLICH · POSSIBLE

✓		Weichholz, Hartholz, Exotenholz, Quer	Soft wood, hard wood, and exotic wood across the grain
✓		Weichholz, Hartholz, Exotenholz Längs	Soft wood, hard wood, and exotic wood along the grain
✓		Leimholz, Tischler- und Furniersperrholz, Schichtholzplatten	Bonded wood, blockboard and veneer plywood, laminated wood
✓		Spanplatten, Hartfaserplatten, Platten ohne Belag LDF, MDF, HDF	Chipboard, hard fibre board, boards without laminate LDF, MDF, HDF
✓		Spanplatten, Hartfaserplatten Kunststoff beschichtet/furniert, MDF, HDF	Chipboard, hard fibre board, plastic-coated/veneered, MDF, HDF
✓		Furniere	Veneers
✓		Profileleisten	Profiled wood
✓		Mineralische/acrylgebundene Massivplatten/Küchenplatten: Corian®, Noblan®, Hi-Macs®, Staron®, Rausolid®, Varicor®	Mineral/acrylic bound solid boards/kitchen worktops: Corian®, Noblan®, Hi-Macs®, Staron®, Rausolid®, Varicor®
✓		HPL-Duroplastische Schichtstoffplatten/Fassadenplatten: Trespa®, Resopal®, Duropal®, Formica®, Kronospan®, Decodur®	HPL High-Pressure-Laminate solid boards/façade panels: Trespa®, Resopal®, Duropal®, Formica®, Kronospan®, Decodur®
✓		Kunststoffe, Plexiglas, Duro- und Thermoplaste	Plastics, plexiglass, acrylics, duro- and thermoplastics
✓		Gips-Zement-Steinwollplatten, Eternit, GFK, CFK, HPL, Mineralwerkstoffe	Gypsum/Cement fibre boards, Rockwool, Eternit, GRP, CFK, HPL, Mineral material

ANWENDUNG · APPLICATION

Geringere Zähnezahlen: Gute Schnittqualität in alle Holzwerkstoffe, Massivholz längs- und quer, Plattenwerkstoffe einseitig furniert oder beschichtet, Hartgewebe, Hartpapiere sowie für dickere Kunststoffplatten/Profile (Thermoplast).

Höhere Zähnezahlen: Sehr gute Schnittqualität in alle Holzwerkstoffe, Massivholz vorzugsweise quer, Plattenwerkstoffe zweiseitig furniert oder beschichtet (ggf. Vorritzer verwenden), Hartgewebe, Hartpapier, Leisten und Furnier, Kunststoff (Thermoplaste, Duroplaste).

Für exzellente Schnittgüte aller Holzwerkstoffe massiv sowie Platten beschichtet/furniert auch auf der Unterseite ohne Vorritzer siehe Art. 11.1320 Seite 625

Lower number of teeth: Good cutting quality in all wooden materials, solid wood across and along the grain, panels and boards one-sided plastic coated/veneered, paper-based laminate, thicker plastic boards/profiles (thermoplastics).

Higher number of teeth: Very good cutting quality in all wooden materials, solid wood across and along the grain, panels and boards two-sided plastic coated/veneered (if applicable with scorer), paper-based laminate, strips and veneer, plastics (thermoplastics, duroplastics)

For excellent cutting in all wooden materials, solid wood an panels/boards two-sided plastic coated/veneered (also without using scorer) see art. 11.1320 page 625



Video







Formatieren Universal + Hundegger · Wechselzahn
Panel sizing universal + Hundegger · Alternate top bevel tooth

Art. **11.1300**

GOLD-STAR LINE 

Art.								€
111300.150.010	● 150	3,2/2,2	30	36 WZ	10	UNI	-	34,00
111300.180.010	● 180	3,2/2,2	30	42 WZ	10	UNI	-	39,90
111300.200.010	● 200	3,2/2,2	30	48 WZ	10	UNI	-	45,60
111300.230.010	● 230	3,2/2,2	30	48 WZ	15	UNI	-	47,50
111300.250.010	● 250	3,2/2,2	30	40 WZ	15	UNI	✓	47,25
111300.250.020	● 250	3,2/2,2	30	48 WZ	15	UNI	✓	51,55
111300.250.030	● 250	3,2/2,2	30	60 WZ	10	UNI	✓	60,15
111300.250.040	● 250	3,2/2,2	30	80 WZ	10	UNI	✓	70,00
111300.300.010	● 300	3,2/2,2	30	48 WZ	15	UNI	✓	58,00
111300.300.020	● 300	3,2/2,2	30	60 WZ	15	UNI	✓	67,20
111300.300.030	● 300	3,2/2,2	30	72 WZ	10	UNI	✓	73,30
111300.300.040	● 300	3,2/2,2	30	96 WZ	10	UNI	✓	88,15
111300.305.010	● 305	3,2/2,2	30	48 WZ	15	UNI	✓	58,00
111300.305.020	● 305	3,2/2,2	30	60 WZ	15	UNI	✓	67,20
111300.305.030	● 305	3,2/2,2	30	72 WZ	10	UNI	✓	73,30
111300.315.010	● 315	3,2/2,2	30	48 WZ	15	UNI	✓	65,40
111300.315.020	● 315	3,2/2,2	30	60 WZ	15	UNI	✓	76,50
111300.315.030	● 315	3,2/2,2	30	72 WZ	10	UNI	✓	79,45
111300.315.040	● 315	3,2/2,2	30	96 WZ	10	UNI	✓	97,20
111300.350.010	● 350	3,5/2,5	30	54 WZ	15	UNI	✓	74,05
111300.350.020	● 350	3,5/2,5	30	72 WZ	15	UNI	✓	86,15
111300.350.030	● 350	3,5/2,5	30	84 WZ	10	UNI	✓	92,35
111300.350.040	● 350	3,5/2,5	30	108 WZ	10	UNI	✓	103,50
111300.370.010	● 370	4,2/2,5	30	60 WZ	15	UNI	✓	93,70
111300.400.010	● 400	3,5/2,5	30	60 WZ	15	UNI	✓	88,95
111300.400.020	● 400	3,5/2,5	30	84 WZ	15	UNI	✓	102,45
111300.400.030	● 400	3,5/2,5	30	96 WZ	10	UNI	✓	111,90
111300.400.040	● 400	3,5/2,5	30	120 WZ	10	UNI	✓	117,50
111300.410.010	● 410	4,2/2,5	30	60 WZ	15	UNI	✓	104,55
111300.450.010	● 450	4,0/2,8	30	66 WZ	15	UNI	✓	109,50
111300.450.020	● 450	4,0/2,8	30	84 WZ	15	UNI	✓	126,55
111300.450.030	● 450	4,0/2,8	30	108 WZ	10	UNI	✓	143,35
111300.450.040	● 450	4,0/2,8	30	132 WZ	10	UNI	✓	171,70
111300.500.010	● 500	4,0/2,8	30	60 WZ	20	UNI+2-10-80	✓	120,60
111300.500.020	● 500	4,0/2,8	30	72 WZ	15	UNI+2-10-80	✓	134,70
111300.500.030	● 500	4,0/2,8	30	96 WZ	15	UNI+2-10-80	✓	158,40
111300.500.040	● 500	4,0/2,8	30	120 WZ	10	UNI+2-10-80	✓	181,75
111300.500.050	● 500	4,0/2,8	30	144 WZ	10	UNI+2-10-80	✓	201,95

SPEZIALPROGRAMM HUNDEGGER / SPECIAL SELECTION HUNDEGGER

Art.	Maschine Machine								€
111300.550.010	Zuschnitt-Automat Turbo-Drive	● 550	6,0/4,4	30	60 WZ	15	8-8,5-120 Angesenkt 2-13-240 Versetzt 22,5°	✓	309,05
111300.600.010		● 600	4,8/3,4	30	48 WZ	15	2-8,5-90+2-10-80+2-15-63	✓	267,25
111300.650.010		● 650	5,8/4,0	30	36 WZ	15	2-8,5-90+2-10-80+2-15-63	✓	293,65
111300.650.020		● 650	5,8/4,0	30	48 WZ	15	2-8,5-90+2-10-80+2-15-63	✓	323,65
111300.650.030		● 650	5,6/4,0	30	96 WZ	12	2-8,5-90+2-10-80+2-15-63	✓	344,00
111300.720.010	Zuschnitt-Automat SC-3	● 720	6,0/4,4	30	72 WZ	15	8-8,5-120 Angesenkt 4-8,1-90 Versetzt 2-14-400 Versetzt	✓	548,80
111300.720.020		● 720	6,0/4,4	30	48 WZ	15	2-8,5-90	✓	475,85
111300.720.030		● 720	6,0/4,4	30	72 WZ	15	2-8,5-90	✓	548,80
111300.735.010		● 735	6,0/4,4	30	72 WZ	15	2-8,5-90	✓	558,40
111300.760.010		● 760	6,0/4,4	30	72 WZ	15	4-8,5-90+2-15-415	✓	564,35
111300.800.010	Abbundmaschine Robot-Drive	● 800	6,0/4,4	30	72 WZ	15	8-8,5-160 Angesenkt 4-8,1-90 Versetzt 2-14-400 Versetzt	✓	569,50
111300.800.020		● 800	6,0/4,4	30	80 WZ	12	4-8,5-90+2-15-415	✓	594,10

Weitere Abmessungen Hundegger kurzfristig auf Anfrage lieferbar
Other sizes Hundegger available at short notice on request
UNI = 2-7-42 + 2-9-46,40 + 2-10-60

1



2



3



4



5



6



7



8



9



10



Art.
100
101
102

Art. **11.1320**



Formatieren Universal Plus · Wechselzahn + Achswinkel

Panel sizing universal plus · Alternate to bevel tooth + axial-angle

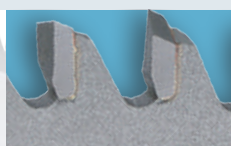
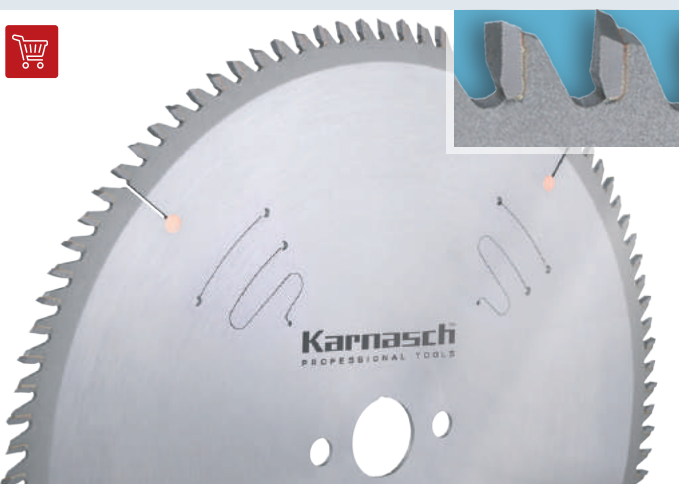

✓ OPTIMAL · OPTIMAL ✓ GUT · GOOD ✓ MÖGLICH · POSSIBLE

✓		Weichholz, Hartholz, Exotenholz, Quer	Soft wood, hard wood, and exotic wood across the grain
✓		Leimholz, Tischler- und Furniersperrholz, Schichtholzplatten	Bonded wood, blockboard and veneer plywood, laminated wood
✓		Spanplatten, Hartfaserplatten, Platten ohne Belag LDF, MDF, HDF	Chipboard, hard fibre board, boards without laminate LDF, MDF, HDF
✓		Spanplatten, Hartfaserplatten Kunststoff beschichtet/furniert, MDF, HDF	Chipboard, hard fibre board, plastic-coated/veneered, MDF, HDF
✓		Furniere	Veneers
✓		Profilleisten	Profiled wood
✓		Kunststoffe, Plexiglas, Duro- und Thermoplaste	Plastics, plexiglass, acrylics, duro- and thermoplastics

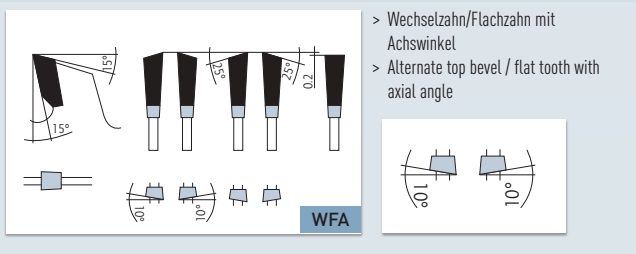

MASCHINE · MACHINE

Plattenaufteilsägen vertikal, Formatkreissägen, Doppelgehrungssägen, mechanische Kappsägemaschinen, Unterflurkappsägemaschinen, CNC-Bearbeitungszentren.

Vertical panel sizing saws, trimming saws, double mitre saws, mechanical chop saws, under frame mounted chop saws, machining centers with saw aggregate.

ANWENDUNG · APPLICATION

Formatieren von Holzwerkstoffen in hervorragender Fertigschnittqualität. **Ausriss-freies** Sägen von beschichteten Holzwerkstoffen auch mit sehr dicken Deckschichten, Massivholz quer, Kunststoffprofile, Kunststoffummantelte Leisten, Furnierte oder Folienummantelte Türzagen...

Panel sizing/trimming of wood-based material in excellent finishing-cut quality. **Splinter-free** sawing of laminated wood-based material including material with very thick top layers, solid wood across the grain, plastic profiles, synthetically coated ledges, veneered or foil-sheathed door frames...

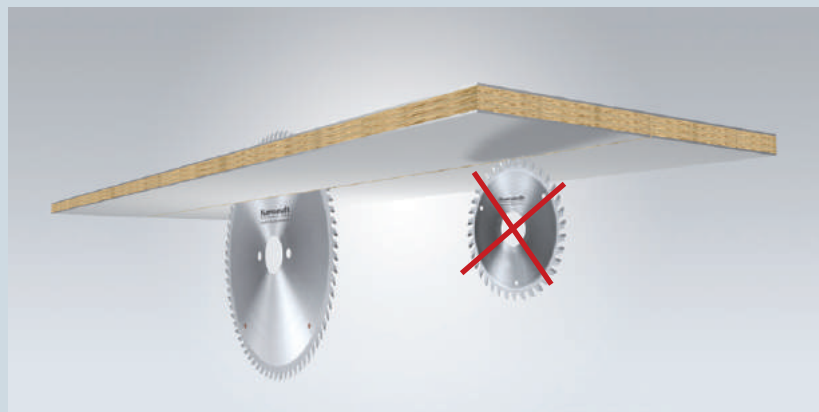

Ritzer nicht erforderlich

Scorer not required



Video

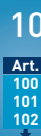

Art.
100
101
102

Formatieren Universal Plus · Wechselzahn + Achswinkel
Panel sizing universal plus · Alternate to bevel tooth + axial-angle

Art. 11.1320

GOLD-STAR LINE 

Art.							€
111320.200.010	• 200	3,0/2,2	30	60 WFA	2-6,2-42 + 4-6-52 + 4-6,6-60	-	122,65
111320.220.010	• 220	3,0/2,2	30	70 WFA	UNI	-	130,65
111320.250.010	• 250	3,0/2,2	30	80 WFA	UNI	✓	141,40
111320.303.010	• 303	3,0/2,2	30	100 WFA	UNI	✓	171,45
111320.350.010	• 350	3,0/2,2	30	100 WFA	UNI	✓	188,75
111320.400.010	• 400	3,0/2,2	30	120 WFA	UNI	✓	229,60
111320.450.010	• 450	3,6/2,8	30	130 WFA	UNI	✓	256,55
111320.500.010	• 500	3,6/2,8	30	140 WFA	UNI	✓	284,35

UNI = 2-7-42 + 2-9-46,40 + 2-10-60

Arbeiten mit Sägewelle **unter** dem Werkstück
Working with spindle **under** the panel



Durch den positiven Spanwinkel wirkt der Schnittdruck über dem Werkstück auf die stabile Tischauflage.
Due to the positive cutting angle acts the cutting pressure above the panel into the stable saw table.

1



2



3



4



5



6



7



8



9



10



Art.
100
101
102

Karnasch® DP-BESTÜCKTE KREISSÄGEBLÄTTER DP TIPPED CIRCULAR SAW BLADES

Art. **11.1370**

GOLD-STAR LINE 

Diamant · Formatieren · Fertigschnitt · Harte Kunststoffe · Abrasive Werkstoffe
Diamond · Panel-sizing · Finishing cut · Hard plastics · Abrasive Materials

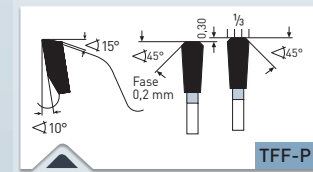

TFF-P





- > Trapez-Flachzahn (mit beidseitiger Schutzfase)
- > Triple-chip/flat tooth (with protective chamfer on both sides)

MASCHINE · MACHINE

Für Formatkreissägen, Plattensägen, Tischkreissägen

For sizing saws, panel saws, bench saws

✓ OPTIMAL · OPTIMAL ✓ GUT · GOOD ✓ MÖGLICH · POSSIBLE

✓		Spanplatten, Hartfaserplatten Kunststoff beschichtet/furniert, MDF, HDF	Chipboard, hard fibre board, plastic-coated/veneered, MDF, HDF
✓		Mineralische/acrylgebundene Massivplatten/Küchenplatten: Corian®, Noblan®, Hi-Macs®, Staron®, Rausolid®, Varicor®	Mineral/acrylic bound solid boards/kitchen worktops: Corian®, Noblan®, Hi-Macs®, Staron®, Rausolid®, Varicor®
✓		HPL-Duroplastische Schichtstoff- platten/Fassadenplatten: Trespa®, Resopal®, Duropal®, Formica®, Kronospan®, Decodur®	HPL High-Pressure-Laminate solid boards/façade panels: Trespa®, Resopal®, Duropal®, Formica®, Kronospan®, Decodur®
✓		Gips-Zement-Steinwollplatten, Eternit, GFK, CFK, HPL, Mineral- werkstoffe	Gypsum/Cement fibre boards, Rockwool, Eternit, GRP, CFK, HPL, Mineral material
✓		Kunststoffe, Plexiglas, Duro- und Thermoplaste	Plastics, plexiglass, acrylics, duro- and thermoplastics

ANWENDUNG · APPLICATION

Durch DP (Polykristalliner Diamant) Zähne extrem lange Standzeiten gegenüber Hartmetall-bestückte Kreissägeblätter. Ideal für Zuschnitte sowie Formatschnitte in extrem abrasive, zu hohen Schneidenschleiß führenden Materialien wie: Corian, Trespa, Laminat, MDF, Gips- und Zementgebundene Platten, Steinwollplatten, Heraklith, Eternit.

Speziell hervorragend ebenfalls für Duroplaste wie: Glasfaserverstärkte sowie Kohlefaserverstärkte Kunststoffe (GFK, CFK), Carbon, Aramidfaserkunststoffe (AFK) HP, HPL, PUR.

Weiterhin hervorragend für Fertigschnitte in thermoplastische Vollplatten (Acrylglas, PMMA, Polyäthylen, Polyamid usw.) sowie duroplastische Vollplatten (Schichtstoffe, HPL, Hartpapier, Trespa, Resopal, Multiplex). Weiterhin für Polymergebundene Kunststoffe, Mineralwerkstoffe wie Corian, Noblan, Hi-Macs, Staron, Rausolid usw.

Hervorragend ebenfalls für Fertigschnitte in beidseitig Kunststoffbeschichteten Plattenwerkstoffe, vorzugsweise in Verbindung mit Vorritzer. Ideal auch zum schneiden von Kunststoff-Profilen.

Due to DP (Polycrystalline Diamond) teeth extremely long tool life compared to carbide tipped circular saws. Excellent for sizing, formatting, cross cuts in extreme abrasive, heavy machining and abrading materials such as: Corian, Trespa, laminates, MDF, gypsum and cement-bonded boards, Rockwool boards, Heraklith products, Eternit.

Also excellent for Duroplastic materials such as: Glas fibre plastic (GFK), Carbon fibre plastic (CFK), Carbon, Aramid fibre plastic (AFK), HP, HPL, PUR.

For finishing cuts in solid thermoplastic boards (PMMA, acrylic glass, polyethylene, polyamide etc.) and solid duroplastic boards (HPL-high-pressure-laminate, HP-Hardpaper, phenolic resin bonded paper, phenolic laminated cotton sheets, Trespa, Resopal, Multiplex). Also for polymer-bound plastics, mineral materials such as Corian, Noblan, Hi-Macs, Staron, Rausolid etc.

Excellent also for finishing cuts in double-side plastic coated boards, preferably in combination with coring sawblades. Ideal also for cutting plastic profiles.



Video









Art.
100
101
102

Diamant · Formatieren · Fertigschnitt · Harte Kunststoffe · Abrasive Werkstoffe
Diamond · Panel-sizing · Finishing cut · Hard plastics · Abrasive Materials

Art. **11.1370**

GOLD-STAR LINE ★

Art.							DP-Bestückungshöhe DP-Tip hight	€
111370.250.010	● 250	3,2/2,2	30	60 TFF-P	UNI	✓	5 mm	886,65
111370.250.020	● 250	3,2/2,2	30	80 TFF-P	UNI	✓	5 mm	1162,55
111370.300.010	● 300	3,2/2,2	30	72 TFF-P	UNI	✓	5 mm	1278,80
111370.300.020	● 300	3,2/2,2	30	96 TFF-P	UNI	✓	4 mm	1384,20
111370.303.010	● 303	3,2/2,2	30	60 TFF-P	UNI	✓	5 mm	934,70
111370.303.020	● 303	3,2/2,2	30	72 TFF-P	UNI	✓	5 mm	1278,80
111370.303.030	● 303	3,2/2,2	30	96 TFF-P	UNI	✓	4 mm	1384,20
111370.350.010	● 350	3,2/2,2	30	84 TFF-P	UNI	✓	5 mm	1333,05
111370.350.020	● 350	3,2/2,2	30	108 TFF-P	UNI	✓	4 mm	1520,60

UNI = 2-7-42 + 2-9-46,40 + 2-10-60

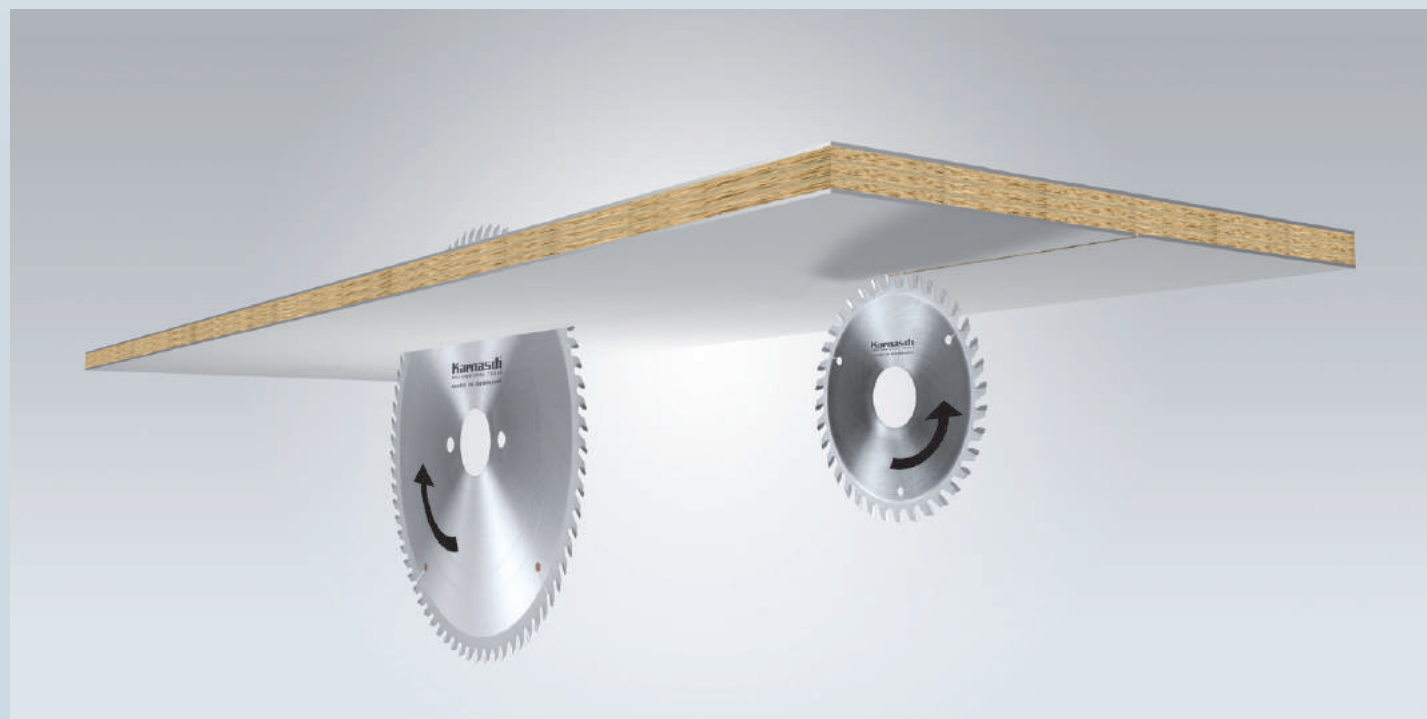

Bei Kunststoff/Melamin beschichtete Plattenwerkstoffe Vorritzen empfohlen. Ritzer siehe Seite 615/669. Sägen von beschichteten/furnierten Plattenwerkstoffe ohne Vorritzer siehe Seite 573, 637, 639, 641, 643, 645

For plastic coated/melamine boards scoring recommended. Scorer see page 615/669. Cutting of coated/veneered boards without scorer see page 573, 637, 639, 641, 643, 645

1



2



3



4



5



6



7



8



9



10



Art.
100
101
102

Art. **11.1425**

GOLD-STAR LINE 

Formatieren Universal · Wechselzahn · Dünnschnitt
Panel-sizing universal · Alternate top bevel tooth · Thin-Cut

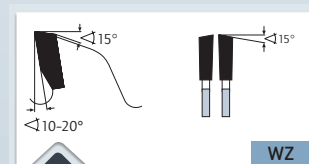
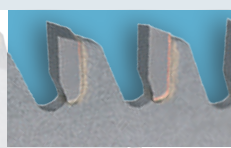









> Wechselzahn
> Alternate top bevel

MASCHINE · MACHINE

Für Handkreissägen, Tauchsägen, Tisch- und Formatkreissägen, Plattenaufteilsägen, Kappsägen, Akkusägen

For portable circular saws, bench- and sizing saws, panel sizing saws, cross-cut saws, cordless saws.

✓ OPTIMAL · OPTIMAL ✓ GUT · GOOD ✓ MÖGLICH · POSSIBLE

✓		Spanplatten, Hartfaserplatten Kunststoff beschichtet/furniert, MDF, HDF	Chipboard, hard fibre board, plastic-coated/veneered, MDF, HDF
✓		Spanplatten, Hartfaserplatten, Platten ohne Belag LDF, MDF, HDF	Chipboard, hard fibre board, boards without laminate LDF, MDF, HDF
✓		Furniere	Veneers
✓		Profileleisten	Profiled wood
✓		Weichholz, Hartholz, Exotenholz, Quer	Soft wood, hard wood, and exotic wood across the grain
✓		Kunststoffe, Plexiglas, Duro- und Thermoplaste	Plastics, plexiglass, acrylics, duro- and thermoplastics
✓		Leimholz, Tischler- und Furnier- sperrholz, Schichtholzplatten	Bonded wood, blockboard and veneer plywood, laminated wood
✓		Mineralische/acrylgebundene Massivplatten/Küchenplatten: Corian®, Noblan®, Hi-Macs®, Staron®, Rausolid®, Varicor®	Mineral/acrylic bound solid boards/kitchen worktops: Corian®, Noblan®, Hi-Macs®, Staron®, Rausolid®, Varicor®
✓		HPL-Duroplastische Schichtstoff- platten/Fassadenplatten: Trespa®, Resopal®, Duropal®, Formica®, Kronospan®, Decodur®	HPL High-Pressure-Laminate solid boards/façade panels: Trespa®, Resopal®, Duropal®, Formica®, Kronospan®, Decodur®

ANWENDUNG · APPLICATION

Durch dünne Schnittbreite ideal auch für Akkumaschinen und für teure Edelhölzer, Furniere und Leisten da wenig Verschnitt und Schnittdruck/Akkuverbrauch.

Niedere Zähnezahl: Grobe bis mittlere Schnittqualität in alle Holzwerkstoffe, Edelhölzer und Massivholz längs- und quer, Plattenwerkstoffe einseitig furniert oder Kunststoff beschichtet, Hartgewebe, Hartpapier, dickere Kunststoffprofile und Platten (Thermoplaste) Hoher Vorschub möglich.

Mittlere Zähnezahl: Gute Schnittqualität in alle Holzwerkstoffe, Edelhölzer, Massivholz und Leisten längs- und quer, Plattenwerkstoffe einseitig/zweiseitig furniert oder Kunststoff beschichtet, Hartgewebe, Hartpapier, Furnier und Furnierpakete sowie Kunststoffprofile und Platten (Thermoplaste, Duroplaste).

Hohe Zähnezahl: Sehr gute Schnittqualität in alle Holzwerkstoffe, Edelhölzer, Massivholz und Leisten vorzugsweise Querschnitte. Plattenwerkstoffe zweiseitig furniert oder Kunststoff beschichtet, Hartgewebe, Hartpapier, Furnier und Furnierpakete sowie Kunststoffprofile und Platten (Thermoplaste, Duroplaste).

Durch spezielles Hartmetall sehr gut zum Sägen harter Thermoplaste wie z.B. dünne Platten, Hohlkammerplatten aus PC (Polycarbonat), PMMA (Acrylglas-Plexiglas) Siehe hierzu auch Artikel 11.1430 Seite 631

Due to Thin-Cut also ideal for battery machines and for cutting expensive precious wood, veneer, strips because of less waste/battery consumption.

Low number of teeth: Coarse to medium cutting quality in all wooden materials, precious wood and solid wood across and along the grain, panel and boards one-side plastic coated/veneered, paper-based laminate, thicker plastic profiles and plates (Thermoplastics). High feed rate possible

Medium number of teeth: Good cutting quality in all wooden materials, precious wood, solid wood and strips across and along the grain, panel and boards one-side/two side plastic coated/veneered, paper-based laminate, veneer and veneer packages, plastic profiles/plates (Thermoplastics, Duroplastics)

High number of teeth: Very good cutting quality in all wooden materials, precious wood, solid wood and strips preferably across the grain, panel and boards two side plastic coated/veneered, paper-based laminate, veneer and veneer packages, plastic profiles/plates (Thermoplastics, Duroplastics)

Due to special carbide also excellent for cutting hard thermoplastics such as thin panels, hollow section boards Made of PC (Polycarbonate), PMMA (Acrylic-glass/Plexiglass). See here also article 11.1430, page 631



Video



1 

2 

3 

4 

5 

6 

7 

8 

9 





10 

Art.
100
101
102

Formatieren Universal · Wechselzahn · Dünnschnitt
Panel-sizing universal · Alternate top bevel tooth · Thin-Cut

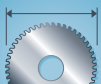
Art. 11.1425

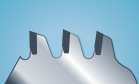
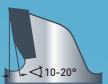
GOLD-STAR LINE 

Art.								€
111425.120.010	● 120	1,8/1,2	20	12 WZ	20	-	-	24,10
111425.120.020	● 120	1,8/1,2	20	28 WZ	15	-	-	31,90
111425.120.030	● 120	1,8/1,2	20	44 WZ	10	-	-	41,30
111425.136.010	● 136	1,8/1,2	20/10	14 WZ	20	-	-	25,05
111425.136.020	● 136	1,8/1,2	20/10	30 WZ	15	-	-	32,15
111425.136.030	● 136	1,8/1,2	20/10	48 WZ	10	-	-	45,35
111425.160.010	● 160	1,8/1,2	20/16	16 WZ	20	2-6-32	-	24,80
111425.160.020	● 160	1,8/1,2	20/16	32 WZ	15	2-6-32	-	34,20
111425.160.030	● 160	1,8/1,2	20/16	54 WZ	10	2-6-32	-	46,35
111425.160.040	● 160	1,8/1,2	20/16	68 WZ	10	2-6-32	-	55,80
111425.165.010	● 165	1,8/1,2	20	16 WZ	20	2-6-32	-	25,05
111425.165.020	● 165	1,8/1,2	20	32 WZ	15	2-6-32	-	34,55
111425.165.030	● 165	1,8/1,2	20	54 WZ	10	2-6-32	-	46,80
111425.165.040	● 165	1,8/1,2	20	68 WZ	10	2-6-32	-	55,80
111425.180.010	● 180	1,8/1,2	20/16	18 WZ	20	2-6-32	-	25,45
111425.180.020	● 180	1,8/1,2	20/16	40 WZ	15	2-6-32	-	38,85
111425.180.030	● 180	1,8/1,2	20/16	60 WZ	10	2-6-32	-	53,10
111425.180.040	● 180	1,8/1,2	20/16	76 WZ	10	2-6-32	-	68,25
111425.190.010	● 190	1,8/1,2	30/20	18 WZ	20	2-7-42	-	27,40
111425.190.020	● 190	1,8/1,2	30/20	42 WZ	15	2-7-42	-	42,90
111425.190.030	● 190	1,8/1,2	30/20	60 WZ	10	2-7-42	-	53,70
111425.190.040	● 190	1,8/1,2	30/20	76 WZ	10	2-7-42	-	68,95
111425.200.010	● 200	2,0/1,4	30	18 WZ	20	2-7-42	-	29,00
111425.200.020	● 200	2,0/1,4	30	42 WZ	15	2-7-42	-	43,45
111425.200.030	● 200	2,0/1,4	30	64 WZ	10	2-7-42	-	54,80
111425.200.040	● 200	2,0/1,4	30	80 WZ	10	2-7-42	-	70,85
111425.210.010	● 210	2,0/1,4	30	20 WZ	20	2-7-42	-	30,50
111425.210.020	● 210	2,0/1,4	30	48 WZ	15	2-7-42	-	44,25
111425.210.030	● 210	2,0/1,4	30	64 WZ	10	2-7-42	-	55,65
111425.210.040	● 210	2,0/1,4	30	80 WZ	10	-	-	71,90
111425.216.010	● 216	2,0/1,4	30	20 WZ	20	2-7-42	-	31,50
111425.216.020	● 216	2,0/1,4	30	48 WZ	15	2-7-42	-	45,05
111425.216.030	● 216	2,0/1,4	30	64 WZ	10	2-7-42	-	56,50
111425.216.040	● 216	2,0/1,4	30	80 WZ	10	2-7-42	-	72,70
111425.220.010	● 220	2,0/1,4	30	48 WZ	20	2-7-42	-	45,05
111425.225.010	● 225	2,0/1,4	30	24 WZ	20	2-7-42	-	31,65
111425.225.020	● 225	2,0/1,4	30	48 WZ	15	2-7-42	-	45,90
111425.225.030	● 225	2,0/1,4	30	68 WZ	10	2-7-42	-	61,40
111425.225.040	● 225	2,0/1,4	30	88 WZ	10	2-7-42	-	79,60
111425.230.010	● 230/235 ●	2,0/1,4	30	24 WZ	20	2-7-42	-	32,45
111425.230.020	● 230/235 ●	2,0/1,4	30	48 WZ	15	2-7-42	-	46,60
111425.230.030	● 230/235 ●	2,0/1,4	30	68 WZ	10	2-7-42	-	62,15
111425.230.040	● 230/235 ●	2,0/1,4	30	88 WZ	10	2-7-42	-	80,35
111425.250.010	● 250	2,2/1,6	30	30 WZ	20	UNI	✓	45,90
111425.250.020	● 250	2,2/1,6	30	56 WZ	15	UNI	✓	65,85
111425.250.030	● 250	2,2/1,6	30	80 WZ	10	UNI	✓	73,55
111425.250.040	● 250	2,2/1,6	30	100 WZ	10	UNI	✓	88,15
111425.260.010	● 260	2,2/1,6	30	30 WZ	20	UNI	✓	47,35
111425.260.020	● 260	2,2/1,6	30	56 WZ	15	UNI	✓	67,20
111425.260.030	● 260	2,2/1,6	30	80 WZ	10	UNI	✓	74,55
111425.270.010	● 270	2,2/1,6	30	30 WZ	20	UNI	✓	47,60
111425.270.020	● 270	2,2/1,6	30	56 WZ	15	UNI	✓	67,45
111425.270.030	● 270	2,2/1,6	30	80 WZ	10	UNI	✓	76,50
111425.300.010	● 300	2,2/1,6	30	36 WZ	20	UNI	✓	56,10
111425.300.020	● 300	2,2/1,6	30	60 WZ	15	UNI	✓	74,05
111425.300.030	● 300	2,2/1,6	30	96 WZ	10	UNI	✓	89,15
111425.300.040	● 300	2,2/1,6	30	120 WZ	10	UNI	✓	108,90
111425.350.010	● 350	2,4/1,8	30	42 WZ	20	UNI	✓	68,70
111425.350.020	● 350	2,4/1,8	30	72 WZ	15	UNI	✓	91,05
111425.350.030	● 350	2,4/1,8	30	108 WZ	10	UNI	✓	103,80
111425.350.040	● 350	2,4/1,8	30	140 WZ	10	UNI	✓	150,55
111425.400.010	● 400	2,8/2,2	30	60 WZ	15	UNI	✓	107,25
111425.400.020	● 400	2,8/2,2	30	96 WZ	10	UNI	✓	142,95
111425.400.030	● 400	2,8/2,2	30	120 WZ	10	UNI	✓	166,80
111425.450.010	● 450	3,1/2,5	30	66 WZ	15	UNI	✓	124,55
111425.450.020	● 450	3,1/2,5	30	108 WZ	10	UNI	✓	160,75
111425.450.030	● 450	3,1/2,5	30	130 WZ	10	UNI	✓	186,05
111425.500.010	● 500	3,4/2,8	30	72 WZ	15	UNI+2-10-80	✓	161,05
111425.500.020	● 500	3,4/2,8	30	120 WZ	10	UNI+2-10-80	✓	213,35
111425.500.030	● 500	3,4/2,8	30	144 WZ	10	UNI+2-10-80	✓	240,15

● Gefertigt/Manufactured 232,50 mm · UNI = 2-7-42 + 2-9-46,40 + 2-10-60



Art.
100
101
102

Karnasch® HARTMETALL-BESTÜCKTE KREISSÄGEBLÄTTER CARBIDE TIPPED CIRCULAR SAW BLADES

Art. **11.1430**

GOLD-STAR LINE

Formatieren · Harte Kunststoffe · Abrasive Werkstoffe · Fertigschnitt/Dünnschnitt
Panel-sizing · Hard plastics · Abrasive materials · Finishing-cut / Thin-cut

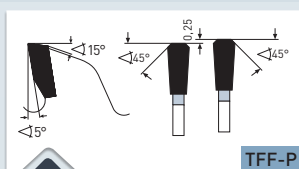
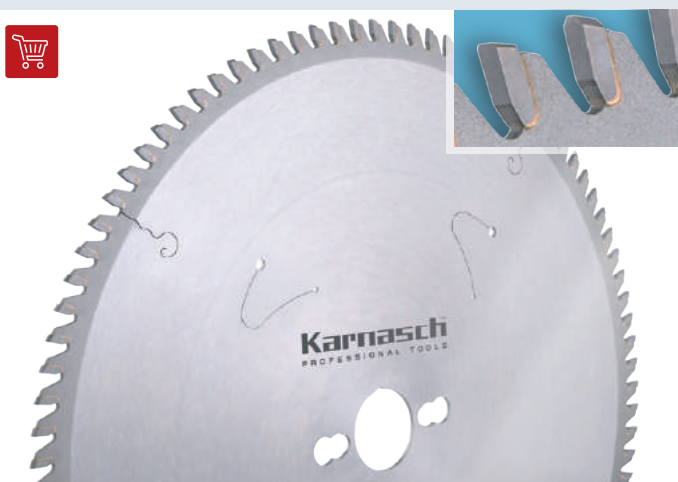

> Trapez Flach Fase Positiv
> Triple-chip/triple-chip teeth

MASCHINE · MACHINE

Für Handkreissägen, Tauchsägen, Tisch- und Formatkreissägen, Plattenaufteilsägen, Kappsägen, Akkusägen

For portable circular saws, bench- and sizing saws, panel sizing saws, cross-cut saws, cordless saws.

✓ OPTIMAL · OPTIMAL ✓ GUT · GOOD ✓ MÖGLICH · POSSIBLE

✓		Gips-Zement-Steinwollplatten, Eternit, GFK, CFK, HPL, Mineralwerkstoffe	Gypsum/Cement fibre boards, Rockwool, Eternit, GRP, CFK, HPL, Mineral material
✓		Mineralische/acrylgebundene Massivplatten/Küchenplatten: Corian®, Noblan®, Hi-Macs®, Staron®, Rausolid®, Varicor®	Mineral/acrylic bound solid boards/kitchen worktops: Corian®, Noblan®, Hi-Macs®, Staron®, Rausolid®, Varicor®
✓		HPL-Duroplastische Schichtstoffplatten/Fassadenplatten: Trespa®, Resopal®, Duropal®, Formica®, Kronospan®, Decodur®	HPL High-Pressure-Laminate solid boards/façade panels: Trespa®, Resopal®, Duropal®, Formica®, Kronospan®, Decodur®
✓		Kunststoffe, Plexiglas, Duro- und Thermoplaste	Plastics, plexiglass, acrylics, duro- and thermoplastics
✓		Dünnbleche, Sandwich Material, Verbundstoffe	Thin iron sheets, sandwich material, composites
✓		Dünne Profile aus Ne-Metall wie Alu, Messing, Kupfer	Thin profiles made of non ferrous materials like alu, copper, brass

ANWENDUNG · APPLICATION

Durch spezielles Hartmetall/Zahnform ideal für Fertigschnitte in dünnen Platten und Profilmaterial aus harten Kunststoffen (Thermoplaste) wie: PVC, PE, PA, ABS, PS, POM PC, PMMA (Acrylglas). z.B. Hohlkammerplatten aus PMMA (Acrylglas).

Ebenfalls gut bei abrasiven, zu hohen Schneidenverschleiß führenden Materialien wie: GFK, CFK, Zementplatten, Gipsfaserplatten, Eternit.

Ebenfalls exzellent geeignet für Sandwichmaterialien mit dünnen Deckschichten. Maximale Deckschichtdicke Nicht-Eisen Metalle / Kunststoffe = 1,0 mm
Maximale Deckschichtdicke Eisenblech = 0,3 mm
Hervorragend auch für dünne Profile bis 1 mm Wandstärke aus Nicht-Eisen-Metalle, wie Alu, Kupfer, Messing.

Durch dünne Schnittbreite wenig Kraftaufwand und Verschnitt. Daher auch ideal für Akku-Maschinen.

Due to special carbide / tooth geometry excellent for finishing cuts in thin plates and profiles made of hard plastics (thermoplastics) such as: PVC, PE, PA, ABS, PS, POM PC, PMMA e.g. hollow section boards of PMMA (acrylic glass).

Also good for abrasive, heavy machining and abrading materials such as: GFK, CFK, fibre cement panels, gypsum, fibre boards, eternit.

Also excellent for sandwich materials with thin layers. Maximum layer thickness for non-ferrous-metals / plastics = 1,0 mm
Maximum layer thickness iron sheet metal = 0,3 mm
Excellent also for thin profiles up to 1 mm thickness made of non-ferrous metal such as aluminum, copper, brass.

Due to thin cutting width little cutting pressure and waste of material. Therefore also ideal for cordless machines.







Video

Formatieren · Harte Kunststoffe · Abrasive Werkstoffe · Fertigschnitt/Dünnschnitt
Panel-sizing · Hard plastics · Abrasive materials · Finishing-cut / Thin-cut

Art. **11.1430**

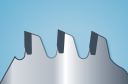
GOLD-STAR LINE 

Art.							€
111430.120.010	● 120	1,8/1,2	20	40 TFF-P	-	-	39,20
111430.160.010	● 160	1,8/1,2	20/16	56 TFF-P	2-6-32	-	47,60
111430.180.010	● 180	1,8/1,2	20/16	60 TFF-P	2-6-32	-	53,10
111430.190.010	● 190	1,8/1,2	30/20	60 TFF-P	2-7-42	-	53,70
111430.200.010	● 200	2,0/1,4	30	64 TFF-P	2-7-42	-	54,80
111430.210.010	● 210	2,0/1,4	30	64 TFF-P	2-7-42	-	55,65
111430.225.010	● 225	2,0/1,4	30	68 TFF-P	2-7-42	-	61,40
111430.230.010	● 230/235 ●	2,0/1,4	30	68 TFF-P	2-7-42	-	62,15
111430.250.010	● 250	2,4/1,8	30	80 TFF-P	UNI	✓	73,55
111430.300.010	● 300	2,4/1,8	30	96 TFF-P	UNI	✓	89,15
111430.350.010	● 350	2,4/1,8	30	108 TFF-P	UNI	✓	103,80
111430.400.010	● 400	3,2/2,5	30	120 TFF-P	UNI	✓	123,25
111430.450.010	● 450	3,5/2,8	30	132 TFF-P	UNI	✓	190,35
111430.500.010	● 500	3,5/2,8	30	144 TFF-P	UNI	✓	245,75

● Gefertigt/Manufactured 232,50 mm · UNI = 2-7-42 + 2-9-46,40 + 2-10-60

1



2



3



4



5



6



7



8



9



10



Art.
100
101
102

Karnasch® HARTMETALL-BESTÜCKTE KREISSÄGEBLÄTTER CARBIDE TIPPED CIRCULAR SAW BLADES

Art. **11.1460**



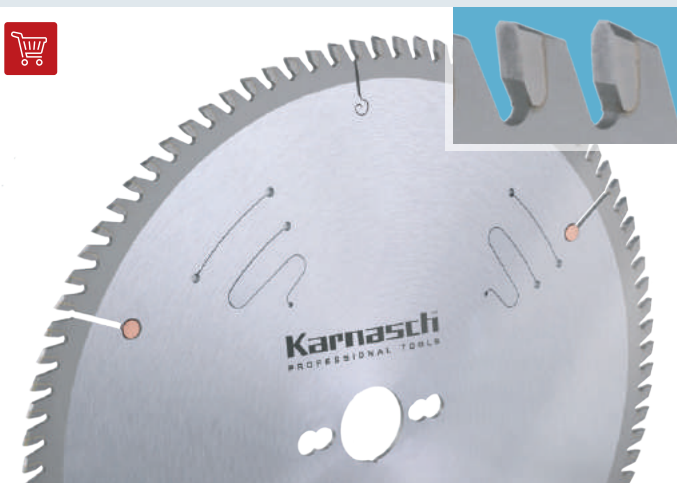

GOLD-STAR LINE 

Formatieren · Harte + abrasive Plattenmaterialien / Trapez-Trapezzahn

Panel-sizing · Hard + abrasive panel materials / Triple-chip/triple-chip tooth



✓ OPTIMAL · OPTIMAL ✓ GUT · GOOD ✓ MÖGLICH · POSSIBLE

✓		Spanplatten, Hartfaserplatten Kunststoff beschichtet/furniert, MDF, HDF	Chipboard, hard fibre board, plastic-coated/veneered, MDF, HDF
✓		Mineralische/acrylgebundene Massivplatten/Küchenplatten: Corian®, Noblan®, Hi-Macs®, Staron®, Rausolid®, Varicor®	Mineral/acrylic bound solid boards/kitchen worktops: Corian®, Noblan®, Hi-Macs®, Staron®, Rausolid®, Varicor®
✓		HPL-Duroplastische Schichtstoff- platten/Fassadenplatten: Trespa®, Resopal®, Duropal®, Formica®, Kronospan®, Decodur®	HPL High-Pressure-Laminate solid boards/façade panels: Trespa®, Resopal®, Duropal®, Formica®, Kronospan®, Decodur®
✓		Gips-Zement-Steinwollplatten, Eternit, GFK, CFK, HPL, Mineral- werkstoffe	Gypsum/Cement fibre boards, Rockwool, Eternit, GRP, CFK, HPL, Mineral material
✓		Kunststoffe, Plexiglas, Duro- und Thermoplaste	Plastics, plexiglass, acrylics, duro- and thermoplastics

- 1 
- 2 
- 3 
- 4 
- 5 
- 6 
- 7 
- 8 
- 9 
- 10 

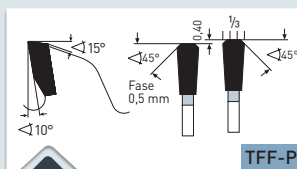

TFF-P

- > Trapez-Flachzahn (Flachzahn mit Fase)
- > Triple-chip/flat tooth (flat tooth with chamfer on both sides)

MASCHINE · MACHINE

Für Formatkreissägen, Plattensägen, Tischkreissägen

For sizing saws, panel saws, bench saws

ANWENDUNG · APPLICATION

Zum Formatieren von Platten in verschiedenen Dicken, Paketschnitte aus Thermo-
plaste wie: PVC, PE, PA, ABS, PS, POM.

Hervorragend auch zum schneiden von Kunststoffprofilen sowie für Fertigschnitte
in beidseitig Kunststoffbeschichtete Span- und Faserwerkstoffe/Platten vorzugs-
weise in Verbindung mit Ritzer.

Durch spezielles Hartmetall auch gut bei abrasiven zu schnellem Schneidenver-
schleiß führenden Verbundstoffen wie faserverstärkte Gipskartonplatten, GFK, CFK.

Ebenfalls ideal für Duroplaste wie HPL Schichtstoff (Trespa, Resopal) und Mineral-
werkstoffe wie Corian, Noblan, Staron usw.

For sizing panels of various thicknesses, cutting stacks made of thermoplastics
such as: PVC, PE, PA, ABS, PS, POM.

Excellent also for cutting plastic profiles and finishing cuts in double-side
plastic coated chip- and hard fibre materials/boards in combination with scoring
sawblades.

Due to special carbide teeth also good for cutting abrasive, heavy machining and
abrading materials such as HPL, high-pressure-laminate (Trespa, Resopal) and
mineral materials such as corian, noblan, staron etc.







Video 

Formatieren · Harte + abrasive Plattenmaterialien / Trapez-Trapezzahn
Panel-sizing · Hard + abrasive panel materials / Triple-chip/triple-chip tooth

Art. **11.1460**

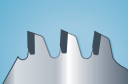
GOLD-STAR LINE 

Art.							€
111460.250.010	• 250	3,2/2,2	30	60 TFF-P	UNI	✓	73,60
111460.250.020	• 250	3,2/2,2	30	80 TFF-P	UNI	✓	92,30
111460.300.010	• 300	3,2/2,2	30	72 TFF-P	UNI	✓	89,80
111460.300.020	• 300	3,2/2,2	30	96 TFF-P	UNI	✓	108,05
111460.303.010	• 303	3,2/2,2	30	60 TFF-P	UNI	✓	78,65
111460.303.020	• 303	3,2/2,2	30	72 TFF-P	UNI	✓	89,80
111460.303.030	• 303	3,2/2,2	30	96 TFF-P	UNI	✓	108,05
111460.350.010	• 350	3,2/2,2	30	84 TFF-P	UNI	✓	106,70
111460.350.020	• 350	3,2/2,2	30	108 TFF-P	UNI	✓	128,95
111460.400.010	• 400	3,5/2,5	30	120 TFF-P	UNI	✓	142,95

UNI = 2-7-42 + 2-9-46,40 + 2-10-60



Bei Kunststoff/Melamin beschichtete Plattenwerkstoffe Vorritzen empfohlen. Ritzer siehe Seite 669. Sägen von beschichteten/furnierten Plattenwerkstoffe ohne Vorritzer siehe Seite 615

For plastic coated/melamine boards scoring recommended. Scorer see page 669. Cutting of coated/veneered boards without scorer see page 615

1



2



3



4



5



6



7



8



9



10



Art.
100
101
102

Karnasch® HARTMETALL-BESTÜCKTE KREISSÄGEBLÄTTER CARBIDE TIPPED CIRCULAR SAW BLADES

Art. **11.1470**

GOLD-STAR LINE

Formatieren Universal · Trapez-Flachzahn
Panel-sizing universal · Triple chip/flat tooth

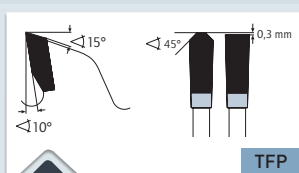
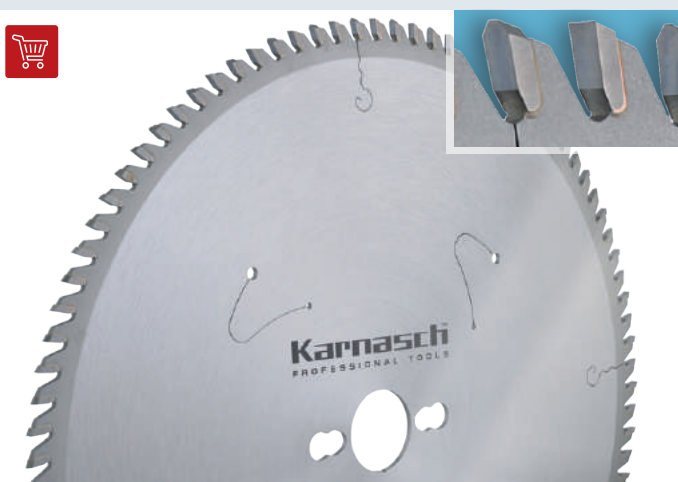

> Trapez-Flachzahn Positiv
> Triple-chip/flat tooth positive

MASCHINE · MACHINE

Für Formatkreissägen, Plattensägen, Tischkreissägen

For sizing saws, panel saws, bench saws

✓ OPTIMAL · OPTIMAL ✓ GUT · GOOD ✓ MÖGLICH · POSSIBLE

✓		Spanplatten, Hartfaserplatten, Platten ohne Belag LDF, MDF, HDF	Chipboard, hard fibre board, boards without laminate LDF, MDF, HDF
✓		Spanplatten, Hartfaserplatten Kunststoff beschichtet/furniert, MDF, HDF	Chipboard, hard fibre board, plastic-coated/veneered, MDF, HDF
✓		Mineralische/acrylgebundene Massivplatten/Küchenplatten: Corian®, Noblan®, Hi-Macs®, Staron®, Rausolid®, Varicor®	Mineral/acrylic bound solid boards/kitchen worktops: Corian®, Noblan®, Hi-Macs®, Staron®, Rausolid®, Varicor®
✓		HPL-Duroplastische Schichtstoffplatten/Fassadenplatten: Trespa®, Resopal®, Duropal®, Formica®, Kronospan®, Decodur®	HPL High-Pressure-Laminate solid boards/façade panels: Trespa®, Resopal®, Duropal®, Formica®, Kronospan®, Decodur®
✓		Kunststoffe, Plexiglas, Duro- und Thermoplaste	Plastics, plexiglass, acrylics, duro- and thermoplastics

ANWENDUNG · APPLICATION

Für Fertigschnitte in thermoplastische Vollplatten (Acrylglas, PMMA, Polyäthylen, Polyamid usw.) sowie duroplastische Vollplatten (Schichtstoffe, HPL, Hartpapier, Trespa, Resopal, Multiplex).

Weiterhin für polymergebundene Kunststoffe, Mineralwerkstoffe wie Corian, Noblan, Hi-Macs, Staron, Rausolid usw.

Hervorragend ebenfalls für Fertigschnitte in beidseitig Kunststoffbeschichteten Plattenwerkstoffe, vorzugsweise in Verbindung mit Vorritzer.

Ideal auch zum schneiden von Kunststoff-Profilen.

For finishing cuts in solid thermoplastic boards (PMMA, acrylic glass, polyethylene, polyamide etc.) and solid duroplastic boards (HPL-high-pressure-laminate, HP-Hardpaper, phenolic resin bonded paper, phenolic laminated cotton sheets, Trespa, Resopal, Multiplex).

Also for polymer-bound plastics, mineral materials such as: Corian, Noblan, Hi-Macs, Staron, Rausolid etc.

Excellent also for finishing cuts in double-side plastic coated boards, preferably in combination with coring sawblades.

Ideal also for cutting plastic profiles.







Video

Formatieren Universal · Trapez-Flachzahn
Panel-sizing universal · Triple chip/flat tooth

Art. **11.1470**

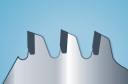
GOLD-STAR LINE 

Art.							€
111470.220.010	• 220	3,2/2,2	30	64 TFP	2-7-42	-	60,75
111470.250.010	• 250	3,2/2,2	30	60 TFP	UNI	✓	66,20
111470.250.020	• 250	3,2/2,2	30	80 TFP	UNI	✓	76,15
111470.300.010	• 300	3,2/2,2	30	72 TFP	UNI	✓	76,10
111470.300.020	• 300	3,2/2,2	30	96 TFP	UNI	✓	88,50
111470.303.010	• 303	3,2/2,2	30	60 TFP	UNI	✓	72,35
111470.303.020	• 303	3,2/2,2	30	72 TFP	UNI	✓	76,10
111470.303.030	• 303	3,2/2,2	30	96 TFP	UNI	✓	88,50
111470.350.010	• 350	3,5/2,5	30	84 TFP	UNI	✓	99,55
111470.350.020	• 350	3,5/2,5	30	108 TFP	UNI	✓	105,60
111470.400.010	• 400	3,5/2,5	30	120 TFP	UNI	✓	123,25

UNI = 2-7-42 + 2-9-46,40 + 2-10-60



Bei Kunststoff/Melamin beschichtete Plattenwerkstoffe Vorritzen empfohlen. Ritzer siehe Seite 669. Sägen von beschichteten/furnierten Plattenwerkstoffe ohne Vorritzer siehe Seite 615

For plastic coated/melamine boards scoring recommended. Scorer see page 669. Cutting of coated/veneered boards without scorer see page 615

1



2



3



4



5



6



7



8



9



10



Art.
100
101
102

Art. **11.1600**



Formatieren · Hohlzahn · Dach-Flach positiv
Panel-sizing · Hollow tooth · Inverted V-flat tooth positive

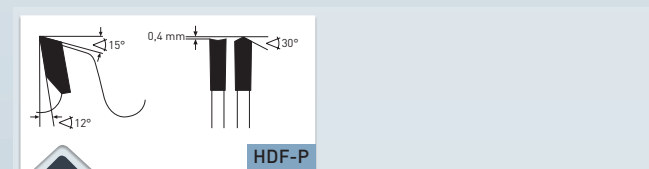

- > Hohlzahn-Dach / flach Positiv
- > Hollow tooth inverted V-flat positive

MASCHINE · MACHINE

Plattenaufteilanlagen wie z.B. von STRIEBIG, HOLZ-HER. Tischkreissägen z.B. von ALTENDORF, MARTIN. Formatsägen, Handkreissägen, Tauchsägen.

Panel-sizing machines for example from STRIEBIG, HOLZ-HER. Circular bench saws for example from ALTENDORF, MARTIN. Sizing machines, portable machines.

✓ OPTIMAL · OPTIMAL ✓ GUT · GOOD ✓ MÖGLICH · POSSIBLE

✓		Spanplatten, Hartfaserplatten Kunststoff beschichtet/furniert, MDF, HDF	Chipboard, hard fibre board, plastic-coated/veneered, MDF, HDF
✓		Spanplatten, Hartfaserplatten, Platten ohne Belag LDF, MDF, HDF	Chipboard, hard fibre board, boards without laminate LDF, MDF, HDF
✓		Kunststoffe, Plexiglas, Duro- und Thermoplaste	Plastics, plexiglass, acrylics, duro- and thermoplastics

ANWENDUNG · APPLICATION

Für Formatschnitte in beidseitig beschichtete Spanplatten (Polyester, Thermoplaste). Belegte Möbelplatten (Furnier, Kunststoff).

Gute Unterkante auch ohne Ritz-Kreissägeblätter.

Für sehr gute Unterkante ohne Ritz-Kreissägeblätter siehe Artikel 11.1320, Seite 625.

For panel sizing two-sided coated chipboards (polyester, thermoplastic). Covered furniture boards (veneer, plastic).

Good cutting quality of the lower edge even without scoring blade.

For very good cutting quality of the lower edge without scoring blade see article 11.1320, page 625



Ritzer nicht erforderlich

Scorer not required



Video



1



2



3



4



5



6



7



8



9



10

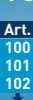





Art.
100
101
102

Formatieren · Hohlzahn · Dach-Flach positiv
Panel-sizing · Hollow tooth · Inverted V-flat tooth positive

Art. **11.1600**

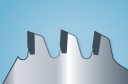
GOLD-STAR LINE 

Art.							€
111600.160.010	● 160	2,8/1,8	20/16	38 HDF-P	2-6-32	-	50,10
111600.180.010	● 180	2,8/1,8	30/20	38 HDF-P	2-7-42	-	51,35
111600.190.010	● 190	2,8/1,8	30	42 HDF-P	2-7-42	-	55,10
111600.200.010	● 200	2,8/1,8	30	48 HDF-P	2-7-42	-	62,15
111600.210.010	● 210	2,8/1,8	30	48 HDF-P	2-7-42	-	62,80
111600.220.010	● 220	3,2/2,2	30	42 HDF-P	2-7-42	-	58,80
111600.250.010	● 250	3,2/2,2	30	48 HDF-P	UNI	✓	71,80
111600.300.010	▲ 300	3,2/2,2	30	72 HDF-P	2-7-42 + 2-10-60	-	93,75
111600.303.010	▲ 303	3,2/2,2	30	40 HDF-P	UNI	✓	80,15
111600.303.020	● 303	3,2/2,2	30	60 HDF-P	UNI	✓	85,00
111600.303.030	● 303	3,2/2,2	30	72 HDF-P	UNI	✓	93,75
111600.350.010	● 350	3,5/2,5	30	72 HDF-P	UNI	✓	113,90
111600.400.010	● 400	3,5/2,5	30	78 HDF-P	UNI	✓	122,85

UNI = 2-7-42 + 2-9-46,40 + 2-10-60

Arbeiten mit Sägewelle **unter** dem Werkstück
Working with spindle **under** the panel



Durch den positiven Spanwinkel wirkt der Schnittdruck über dem Werkstück auf die stabile Tischauflage.
Due to the positive cutting angle acts the cutting pressure above the panel into the stable saw table.

1



2



3



4



5



6



7



8



9



10



Art.
100
101
102

Art. **11.1602**



Formatieren · Hohlzahn · Dach-Flach negativ
Panel-sizing · Hollow tooth · Inverted V-flat tooth negative



✓ OPTIMAL · OPTIMAL ✓ GUT · GOOD ✓ MÖGLICH · POSSIBLE

✓		Spanplatten, Hartfaserplatten Kunststoff beschichtet/furniert, MDF, HDF	Chipboard, hard fibre board, plastic-coated/veneered, MDF, HDF
✓		Spanplatten, Hartfaserplatten, Platten ohne Belag LDF, MDF, HDF	Chipboard, hard fibre board, boards without laminate LDF, MDF, HDF
✓		Kunststoffe, Plexiglas, Duro- und Thermoplaste	Plastics, plexiglass, acrylics, duro- and thermoplastics

- 1
- 2
- 3
- 4
- 5
- 6
- 7
- 8
- 9
- 10

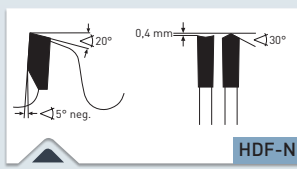

> Hohlzahn-Dach / flach negativ
> Hollow tooth inverted V-flat negative

MASCHINE · MACHINE

Plattenaufteilsägen, speziell auch für vertikale Plattenaufteilsägen wie z.B. von STRIEBIG, HOLZ-HER. Tischkreissägen z.B. von ALTENDORF, MARTIN. Kapp- und Gehrungssägen, Formatsägen.

Panel-sizing machines in particular also for vertical panel-sizing machines for example from STRIEBIG, HOLZ-HER. Circular bench saws for example from ALTENDORF, MARTIN. Chop- and mitre saws, sizing machines.

ANWENDUNG · APPLICATION

Für Formatschnitte in beidseitig beschichtete Spanplatten (Polyester, Thermoplaste). Belegte Möbelplatten (Furnier, Kunststoff).

Vorteile der negativen Zahnform:

- Das Blatt ist besser von Hand zu führen (manueller Vorschub) und wird nicht in das Schnittgut gezogen.
- Daher ideal auch für Kapp- und Gehrungssägen sowie vertikale Plattenaufteilsägen.
- Kompakter und somit stabiler und bruchunempfindlicher.

Gute Unterkante auch ohne Ritz-Kreissägeblätter.

Für sehr gute Unterkante ohne Ritz-Kreissägeblätter siehe Artikel 11.1320, Seite 625

For panel sizing two-sided coated chipboards (polyester, thermoplastic). Covered furniture boards (veneer, plastic).

Advantages of the negative tooth shape:

- Due to the negative tooth shape easy guiding by hand (manual feed).
- The blade is not pulled into the material to be cut.
- Therefore excellent for chop- and mitre saws, vertical panel-sizing machines.
- Compact and thus more stable and shatter-insensitive.

Good cutting quality of the lower edge even without scoring blade.

For very good cutting quality of the lower edge without scoring blade see article 11.1320, page 625

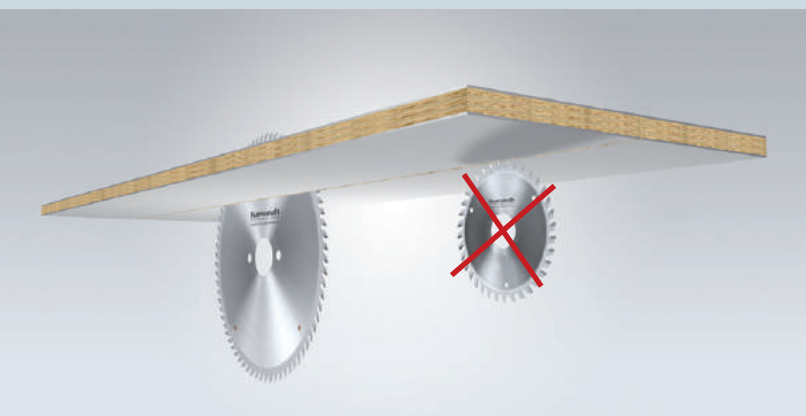

Ritzer nicht erforderlich

Scorer not required







Video

- Art. 100
- 101
- 102

Formatieren · Hohlzahn · Dach-Flach negativ
Panel-sizing · Hollow tooth · Inverted V-flat tooth negative

Art. 11.1602

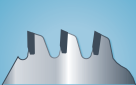
GOLD-STAR LINE

Art.							€
111602.216.010	• 216	2,8/1,8	30	48 HDF-N	2-7-42	-	63,55
111602.220.010	• 220	3,2/2,2	30	42 HDF-N	2-7-42	-	58,80
111602.250.010	• 250	3,2/2,2	30	48 HDF-N	UNI	✓	71,80
111602.303.010	• 303	3,2/2,2	30	60 HDF-N	UNI	✓	85,00
111602.303.020	• 303	3,2/2,2	30	72 HDF-N	UNI	✓	93,75
111602.350.010	• 350	3,5/2,5	30	72 HDF-N	UNI	✓	113,90

UNI = 2-7-42 + 2-9-46,40 + 2-10-60

Arbeiten mit Sägewelle **über** dem Werkstück
Working with spindle **over** the panel

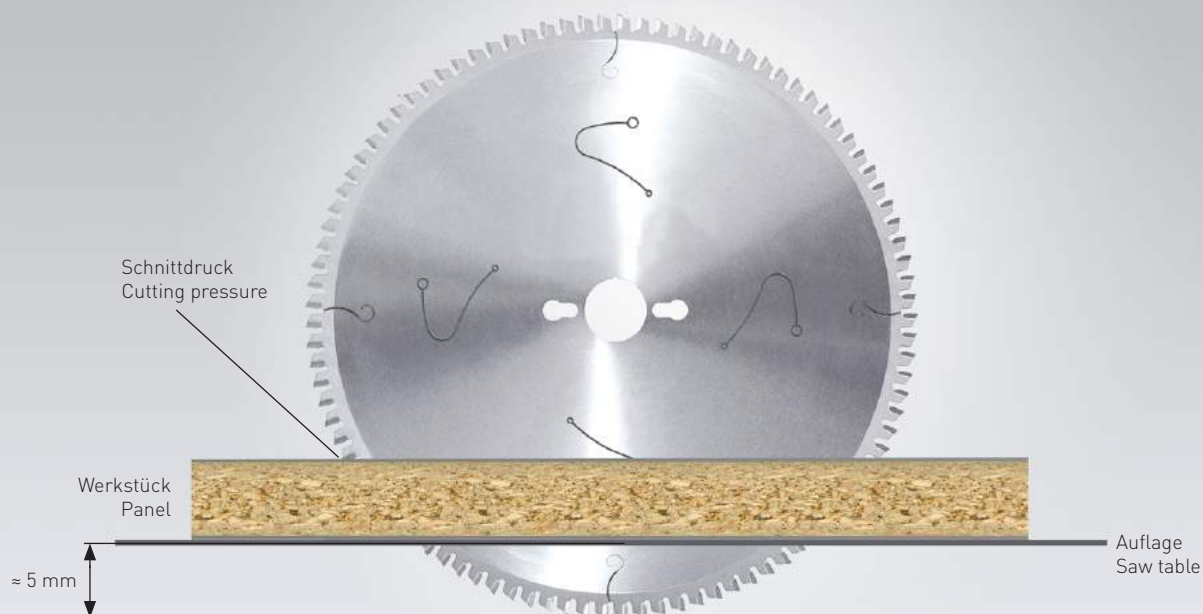

Durch den negativen Spanwinkel wirkt der Schnittdruck über dem Werkstück auf die stabile Tischauflage.
Due to the negative cutting angle acts the cutting pressure above the panel into the stable saw table.

1



2



3



4



5



6



7



8



9



10



Art.
100
101
102



Art. **11.1604**

GOLD-STAR LINE 

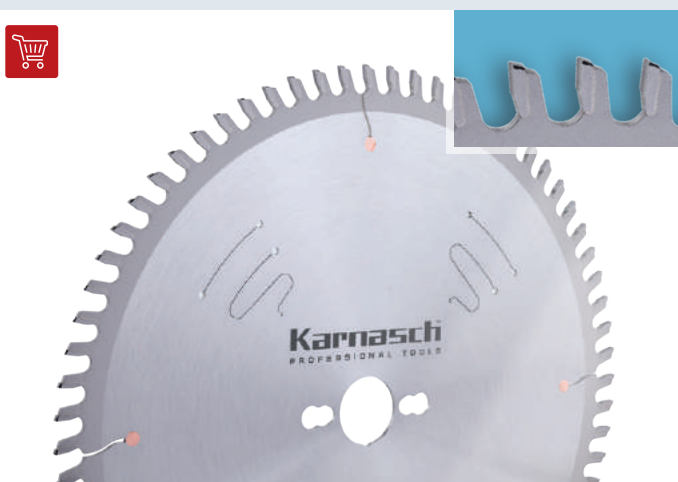
Formatieren · Hohlzahn · Trapez-Trapez positiv
Panel-sizing · Hollow tooth · Triple-chip / Triple-chip positive



✓ OPTIMAL · OPTIMAL ✓ GUT · GOOD ✓ MÖGLICH · POSSIBLE

✓		Spanplatten, Hartfaserplatten Kunststoff beschichtet/furniert, MDF, HDF	Chipboard, hard fibre board, plastic-coated/veneered, MDF, HDF
✓		Spanplatten, Hartfaserplatten, Platten ohne Belag LDF, MDF, HDF	Chipboard, hard fibre board, boards without laminate LDF, MDF, HDF
✓		Kunststoffe, Plexiglas, Duro- und Thermoplaste	Plastics, plexiglass, acrylics, duro- and thermoplastics

1



2



3



4



5



6



7



8



9



10

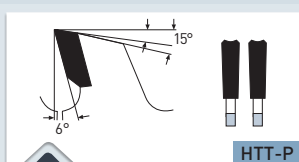

HTT-P

- > Hohlzahn Trapez / Trapez Positiv
- > Hollow tooth triple-chip / triple-chip positive

MASCHINE · MACHINE

Plattenaufteilanlagen wie z.B. von STRIEBIG, HOLZ-HER. Tischkreissägen z.B. von ALTENDORF, MARTIN. Formatsägen, Handkreissägen, Tauchsägen.

Panel-sizing machines for example from STRIEBIG, HOLZ-HER. Circular bench saws for example from ALTENDORF, MARTIN. Sizing machines, portable machines.

ANWENDUNG · APPLICATION

Für Formatschnitte in beidseitig beschichtete Spanplatten (Polyester, Thermoplaste) Holzwerkstoffe wie Spanplatten, Hartfaserplatten. Belegte Möbelplatten (Furnier, Kunststoff). Thermoplaste.

Vorteile der Trapez-Trapez Verzahnung:

- Da jeder Zahn gleichmäßig im Eingriff ist ergeben sich höhere Standzeiten und bessere Schnittqualität als Hohlzahn Dach-Flach Blätter.
- Durch dünne Schnittbreite weniger Verschnitt.
- Ideal für harte Oberflächen welche leicht splintern / ausreißen.
- Gut zum Trennen harter Thermoplaste, PMMA (Plexiglas), PA, PE, PS, POM usw. bis ca. 10 mm.

Gute bis sehr gute Unterkante auch ohne Ritz-Kreissägeblätter.

Für sehr gute Unterkante auch ohne Ritz-Kreissägeblätter siehe Artikel 11.1320, Seite 625

For panel sizing two-sided coated chipboards (polyester, thermoplastic) wooden panel material laminated such as chipboards, fibre boards. Covered furniture boards (veneer, plastic). Thermoplastics.

Advantages of the triple-chip / triple-chip tooth:

- Each tooth evenly in engagement results in longer life and cutting quality than inverted V / Flat hollow tooth.
- Because of thin-cut blades less waste.
- Excellent for clean cutting edges in hard surfaces that splinter / break out easily.
- Good also for cutting hard thermoplastics such as PMMA (acrylic glass), PA, PE, PS, POM etc. up to 10 mm.

Good up to very good cutting quality of the lower edge even without scoring blade.

For very good cutting quality of the lower edge even without scoring blade see article 11.1320, page 625

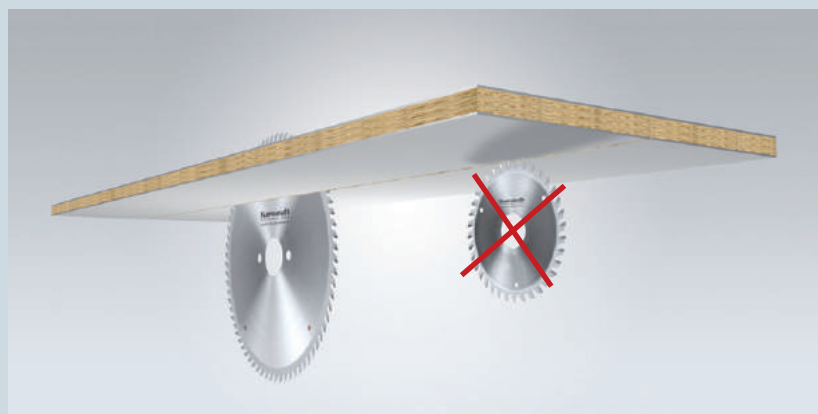

Ritzer nicht erforderlich





Scorer not required



Formatieren · Hohlzahn · Trapez-Trapez positiv
Panel-sizing · Hollow tooth · Triple-chip / Triple-chip positive

Art. 11.1604

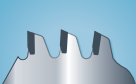
GOLD-STAR LINE

Art.							€
111604.220.010	• 220	2,9/2,0	30	48 HTT-P	2-7-42	-	58,80
111604.250.010	• 250	2,9/2,0	30	60 HTT-P	UNI	✓	86,25
111604.303.010	• 303	2,9/2,0	30	72 HTT-P	UNI	✓	93,75
111604.350.010	• 350	2,9/2,2	30	84 HTT-P	UNI	✓	125,20

UNI = 2-7-42 + 2-9-46,40 + 2-10-60

Arbeiten mit Sägewelle **unter** dem Werkstück
Working with spindle **under** the panel



Durch den positiven Spanwinkel wirkt der Schnittdruck über dem Werkstück auf die stabile Tischauflage.
Due to the positive cutting angle acts the cutting pressure above the panel into the stable saw table.

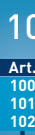

Art.
100
101
102

Art. **11.1610**

Formatieren · Wechselzahn extrem 35° · Positiv
Panel-sizing · Alternate top bevel extreme 35° · Positive

GOLD-STAR LINE 

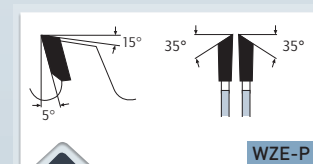







> Wechselzahn extrem 35° Positiv
> Alternate top bevel extreme 35° positive

MASCHINE · MACHINE

Plattenaufteilanlagen wie z.B. von STRIEBIG, HOLZ-HER. Tischkreissägen z.B. von ALTENDORF, MARTIN. Formatsägen, Handkreissägen, Tauchsägen.

Panel-sizing machines for example from STRIEBIG, HOLZ-HER. Circular bench saws for example from ALTENDORF, MARTIN. Sizing machines, portable machines.

✓ OPTIMAL · OPTIMAL ✓ GUT · GOOD ✓ MÖGLICH · POSSIBLE

✓		Weichholz, Hartholz, Exotenholz, Quer	Soft wood, hard wood, and exotic wood across the grain
✓		Leimholz, Tischler- und Furniersperrholz, Schichtholzplatten	Bonded wood, blockboard and veneer plywood, laminated wood
✓		Spanplatten, Hartfaserplatten, Platten ohne Belag LDF, MDF, HDF	Chipboard, hard fibre board, boards without laminate LDF, MDF, HDF
✓		Spanplatten, Hartfaserplatten Kunststoff beschichtet/furniert, MDF, HDF	Chipboard, hard fibre board, plastic-coated/veneered, MDF, HDF
✓		Furniere	Veneers
✓		Profileleisten	Profiled wood
✓		Kunststoffe, Plexiglas, Duro- und Thermoplaste	Plastics, plexiglass, acrylics, duro- and thermoplastics

ANWENDUNG · APPLICATION

Für sehr **glatte ausrissfreie** Schnitte bei Massivholz-Querbearbeitung sowie in Massivholzleisten, Kunststoff- und Furnier ummantelte Profile, Leisten und Türzagen.

Splitterfrei schneiden von beidseitig Kunststoff (z.B. Melamin) beschichtete und furnierte Platten.

Hervorragender Schnitt ebenfalls in MDF, Rohe Spanplatten, Leim- und Schicht-hölzer, Sperrholz, Kunststoffprofile und Leisten, Furniere und Profileleisten, harte Thermoplaste bis ca. 30 mm.

Sehr gute Unterkante auch ohne Ritz-Kreissägeblätter.

Weitere Blätter mit guter bis sehr guter Unterkante auch ohne Ritz-Kreissägeblätter siehe Artikel 11.1320, Seite 625

For very **smooth and tear free / splinter** free cutting in solid wood across the grain and profiles, ledges and door frames of wooden material in plastic coated / foil sheathed / veneered.

Tear-free / splinter free cutting of two-sided plastic coated (for example melamine faced) or veneered chipboards, hard fibre boards.

Excellent also for MDF, plywood, glued laminate, veneers and beading, plastic profiles, hard thermoplastics up to 30 mm.

Very good cutting quality of the lower edge even without scoring blade.

Further blades with good and very good cutting quality of the lower edge without scoring blade see article 11.1320, page 625

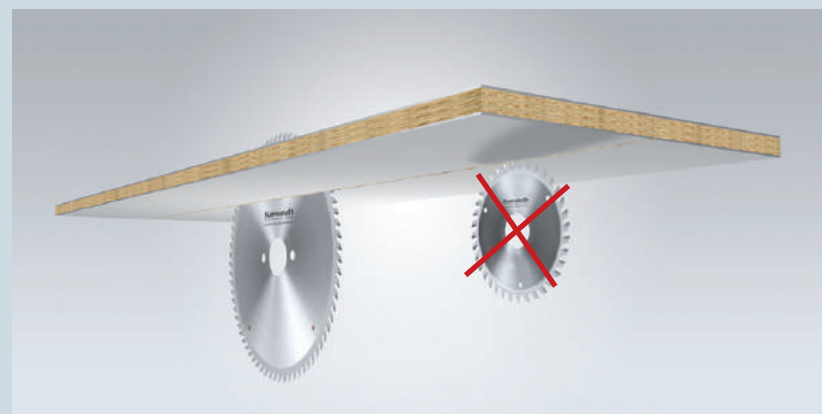

Ritzer nicht erforderlich

Scorer not required



Video



1 

2 

3 

4 

5 

6 

7 

8 

9 





10 

Art. 100 101 102

Formatieren · Wechselzahn extrem 35° · Positiv
Panel-sizing · Alternate top level extreme 35° · Positive

Art. **11.1610**

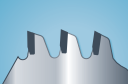
GOLD-STAR LINE 

Art.							€
111610.160.010	• 160	2,8/1,8	20/16	54 WZE-P	2-6-32	-	49,60
111610.190.010	• 190	2,8/1,8	30	60 WZE-P	2-7-42	-	56,05
111610.200.010	• 200	2,8/1,8	30	64 WZE-P	2-7-42	-	60,10
111610.210.010	• 210	2,8/1,8	30	64 WZE-P	2-7-42	-	60,95
111610.220.010	• 220	3,2/2,2	30	68 WZE-P	2-7-42	-	64,85
111610.230.010	• 230/235 ●	2,8/1,8	30	68 WZE-P	2-7-42	-	65,25
111610.250.010	• 250	3,2/2,2	30	80 WZE-P	UNI	✓	73,75
111610.300.010	• 300	3,2/2,2	30	96 WZE-P	UNI	✓	90,65
111610.303.010	• 303	3,2/2,2	30	96 WZE-P	UNI	✓	90,65
111610.350.010	• 350	3,5/2,2	30	108 WZE-P	UNI	✓	129,95

UNI = 2-7-42 + 2-9-46,40 + 2-10-60 ● Gefertigt/Manufactured 232,50 mm

Arbeiten mit Sägewelle **unter** dem Werkstück
Working with spindle **under** the panel



Durch den positiven Spanwinkel wirkt der Schnittdruck über dem Werkstück auf die stabile Tischauflage.
Due to the positive cutting angle acts the cutting pressure above the panel into the stable saw table.

1



2



3



4



5



6



7



8



9



10



Art.
100
101
102

Art. **11.1615**

GOLD-STAR LINE 

Formatieren · Wechselzahn extrem 35° · Negativ
Panel-sizing · Alternate top bevel extreme 35° · Negative

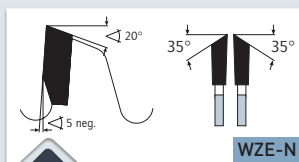

> Wechselzahn extrem 35° Negativ
> Alternate top bevel extreme 35° negative

MASCHINE · MACHINE

Plattenaufteilsägen, speziell auch für vertikale Plattenaufteilsägen wie z.B. von STRIEBIG, HOLZ-HER. Tischkreissägen z.B. von ALTENDORF, MARTIN. Kapp- und Gehrungssägen, Formatsägen.





Panel-sizing machines in particular also for vertical panel-sizing machines for example from STRIEBIG, HOLZ-HER. Circular bench saws for example from ALTENDORF, MARTIN. Chop- and mitre saws, sizing machines.

Ritzer nicht erforderlich

Scorer not required

644

✓ OPTIMAL · OPTIMAL ✓ GUT · GOOD ✓ MÖGLICH · POSSIBLE

✓		Weichholz, Hartholz, Exotenholz, Quer	Soft wood, hard wood, and exotic wood across the grain
✓		Leimholz, Tischler- und Furniersperrholz, Schichtholzplatten	Bonded wood, blockboard and veneer plywood, laminated wood
✓		Spanplatten, Hartfaserplatten, Platten ohne Belag LDF, MDF, HDF	Chipboard, hard fibre board, boards without laminate LDF, MDF, HDF
✓		Spanplatten, Hartfaserplatten Kunststoff beschichtet/furniert, MDF, HDF	Chipboard, hard fibre board, plastic-coated/veneered, MDF, HDF
✓		Furniere	Veneers
✓		Profileleisten	Profiled wood
✓		Kunststoffe, Plexiglas, Duro- und Thermoplaste	Plastics, plexiglass, acrylics, duro- and thermoplastics

ANWENDUNG · APPLICATION

Für sehr **glatte ausrissfreie** Schnitte bei Massivholz-Querbearbeitung sowie in Massivholzleisten, Kunststoff- und Furnier ummantelte Profile, Leisten und Türzagen.

Splitterfreies schneiden von beidseitig Kunststoff (z.B. Melamin) beschichtete und furnierte Platten.

Hervorragender Schnitt ebenfalls in MDF, Rohe Spanplatten, Leim- und Schicht-hölzer, Sperrholz, Kunststoffprofile und Leisten, Furniere und Profileleisten, harte Thermoplaste bis ca. 30 mm.

Vorteile der negativen Zahnform:

- Das Blatt ist besser von Hand zu führen (manueller Vorschub) und wird nicht in das Schnittgut gezogen.
- Daher ideal auch für Kapp- und Gehrungssägen sowie vertikale Plattenaufteil-sägen.
- Kompakter und somit stabiler und bruchunempfindlicher.

Sehr gute Unterkante auch ohne Ritz-Kreissägeblätter.

Weitere Blätter mit guter bis sehr guter Unterkante auch ohne Ritz-Kreissäge-blätter siehe Artikel 11.1320, Seite 625

For very **smooth and tear free / splinter** free cutting in solid wood across the grain and profiles, ledges and door frames of wooden material in plastic coated /foil sheathed / veneered.

Tear-free / splinter free cutting of two-sided plastic coated (for example melamine faced) or veneered chipboards, hard fibre boards.

Excellent also for MDF, plywood, glued laminate, veneers and beading, plastic profiles, hard thermoplastics up to 30 mm.

Advantages of the negative tooth shape:

- Due to the negative tooth shape easy guiding by hand (manual feed).
- The blade is not pulled into the material to be cut.
- Therefore excellent for chop- and mitre saws, vertical panel-sizing machines.
- Compact and thus more stable and shatter-insensitive.

Very good cutting quality of the lower edge even without scoring blade.

Further blades with good and very good cutting quality of the lower edge without scoring blade see article 11.1320, page 625

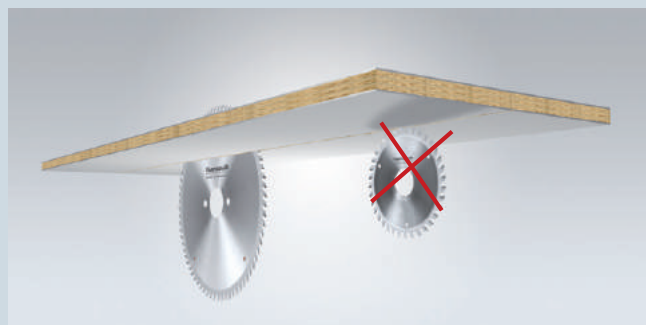





Video

Formatieren · Wechselzahn extrem 35° · Negativ
Panel-sizing · Alternate top bevel extreme 35° · Negative

Art. 11.1615

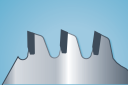
GOLD-STAR LINE 

Art.							€
111615.216.010	● 216	2,8/1,8	30	64 WZE-N	2-7-42	-	61,80
111615.220.010	● 220	3,2/2,2	30	68 WZE-N	2-7-42	-	64,85
111615.250.010	● 250	3,2/2,2	30	80 WZE-N	UNI	✓	73,75
111615.300.010	● 300	3,2/2,2	30	96 WZE-N	UNI	✓	90,65
111615.303.010	● 303	3,2/2,2	30	96 WZE-N	UNI	✓	90,65
111615.350.010	● 350	3,5/2,5	30	108 WZE-N	UNI	✓	129,95
111615.355.010	▲ 355	3,5/2,5	30	100 WZE-N	2-10-60	✓	119,00

UNI = 2-7-42 + 2-9-46,40 + 2-10-60

Arbeiten mit Sägewelle **über** dem Werkstück
Working with spindle **over** the panel

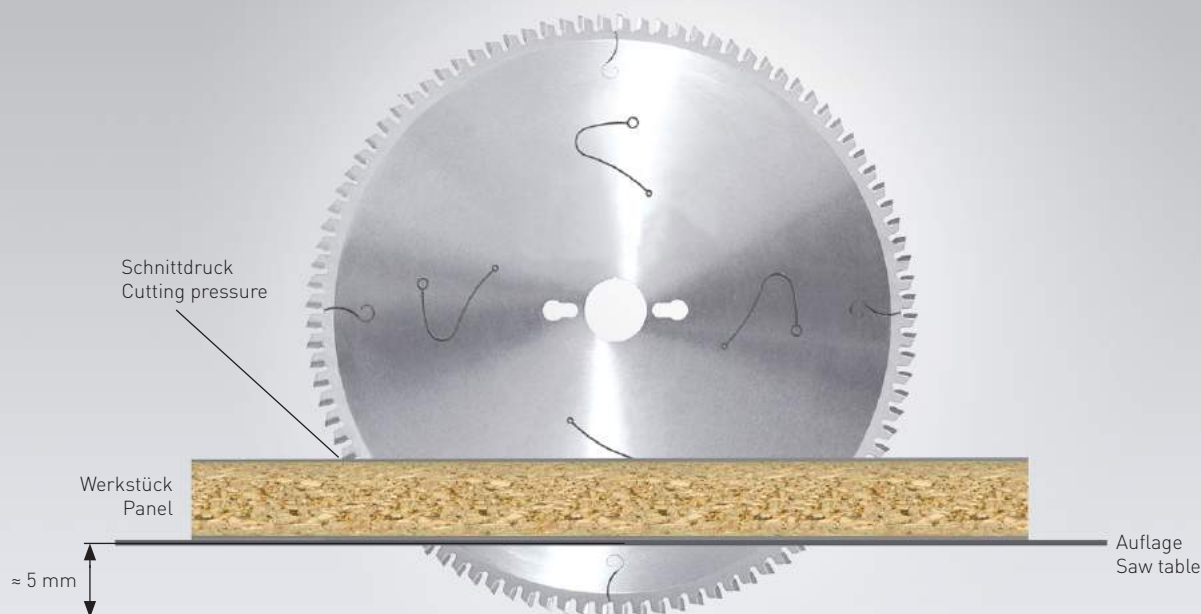

Durch den negativen Spanwinkel wirkt der Schnittdruck über dem Werkstück auf die stabile Tischauflage.
Due to the negative cutting angle acts the cutting pressure above the panel into the stable saw table.

1



2



3



4



5



6



7



8



9



10



Art.
100
101
102

Massivholz

Solid wood

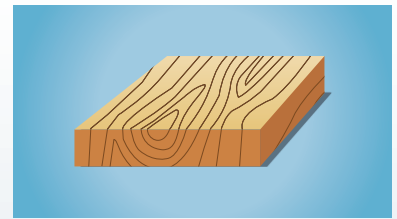

Schnittwertempfehlungen · Recommended cutting values

Werkstoffgruppe Material Group	Werkstoffbeispiele Material examples	Vc (m/s) Schnittgeschwindigkeit Cutting speed	fz (mm/z) Vorschub pro Zahn Feed per tooth
Weichholz Soft wood	Fichte, Kiefer, Pappel, Balsa Spruce, Pine, Poplar, Balsa	60-100	0,5 - 3,0 Längsschnitt Longitudinal cut
			0,2 - 0,4 Querschnitt cut crosswise
Hartholz, Exotenzholz Hard wood, exotic wood	Eiche, Buche, Bankirai, Teak Oak, Beech, Bankirai, Teak	60-100	0,3 - 1,0 Längsschnitt Longitudinal cut
			0,05 - 0,15 Querschnitt cut crosswise

Drehzahl n (U/min) · Revolution per minute n (rpm)

	1500	2000	2500	2850	3000	4000	4500	5000	5600	6000	8000	9000	10000	12000	18000
80 Ø	6,5	8,5	10,5	12	13	17	19	21	23,5	26	34	38	42	52	76
90 Ø	7	9,5	12	13,5	14	19	21	24	26,5	28	38	42	48	56	84
100 Ø	8	10,5	13	15	16	21	24	26	29	32	42	48	52	54	96
120 Ø	9,5	13	16	18	19	26	28	32	35	38	52	56	64	76	112
125 Ø	10	13,5	16,5	18,5	19,5	27	29	33	36,5	39	54	59	66	78	118
140 Ø	11	15	18	21	22	30	33	36	41	44	60	66	72	88	132
150 Ø	12	15,5	19,5	22,5	23,5	31,5	33,5	39	44	47	63	70,5	78,5	94,5	141,5
160 Ø	13	17	21	24	26	34	38	42	47	52	68	76	84	104	152
180 Ø	14	19	24	27	28	38	42,5	48	53	56	76	85	96	118	170
200 Ø	16	21	26	30	32	42	47	52	58,5	64	84	94	104	128	188
225 Ø	18	24	30	33,5	36	48	58	60	66	72	96	106	120	144	212
250 Ø	20	26	33	37	40	52	59	66	73,5	80	104	118	132	160	236
300 Ø	24	31,5	40	45	48	63	71	80	88	96	126	142	160	192	284
350 Ø	28	36,5	47	52	56	73	88	94	105	112	146	166	188	224	332
400 Ø	32	42	54	60	64	84	94	108	117	128	168	188	216	256	376
450 Ø	35,5	47	59	67,5	70,5	94,5	106	118	132	141,6	188	211	236	283	424
500 Ø	40	53	67	74,5	80	106	118	134	146,5	160	212	236	268	320	472

Schnittgeschwindigkeit in m/s · Cutting speed in m/s

① Massivholz · Solid wood

② Sicherheitsgrenze · Safety limits

Festlegung der Schnittgeschwindigkeit Vc
 Determination of cutting speed Vc

$$Vc (m/s) = \frac{D \cdot \pi \cdot n}{60 \cdot 1000}$$

Festlegung der Vorschubgeschwindigkeit Vf
 Determination of feed rate Vf

$$Vf (m/min) = \frac{fz \cdot n \cdot Z}{1000}$$

Vc (m/s) = Schnittgeschwindigkeit · Cutting speed

Vf (m/min) = Vorschubgeschwindigkeit · Feed rate

fz (mm/z) = Vorschub pro Zahn · Feed per tooth

D (mm) = Sägendurchmesser · Saw blade diameter

n (min⁻¹) = Drehzahl · rpm

Z = Anzahl der Zähne · Number of teeth



Massivholz

Solid wood

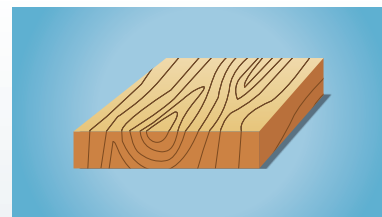

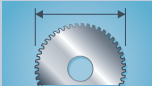
Art. Ø mm	Type	Anwendung · Application	
11.1200 Ø mm 250-800 	Zuschnitt Kreissägeblatt · Wechselzahn mit Abweiser	Für Zuschnitte in Weich- und Hartholz sowie für Brennholz, Bauhölzer, Schalungsplatten, Rohspanplatten.	650
	Rip sawblade · Alternate bevel tooth with chip limiter	For ripping and cross cutting in soft and hard wood, as well as for cutting firewood, construction wood, plywood boards, raw chipboards.	
11.1215 Ø mm 150-500 	Zuschnitt Kreissägeblatt · Wechselzahn	Für Zuschnitte in Weich- und Hartholz sowie für Brennholz, Bauhölzer, Schalungsplatten, Rohspanplatten. Generell für Massivholzverarbeitung auch nass.	651
	Rip sawblade · Alternate top bevel tooth	For ripping and cross cutting in soft and hard wood, as well as for cutting firewood, construction wood, plywood boards, raw chipboards. In general for solid wood also wet.	
11.1220 Ø mm 250-400 	Zuschnitt Kreissägeblatt · Flachzahn mit Abweiser	Für große und schnelle Zuschnitte in weich- und mittelharte Hölzer sowie Naturhölzer wie sie in Tischlereien und Zimmereigeschäften verwendet werden.	652
	Rip sawblade · Flat tooth with chip limiter	For rough and quick cuts in soft and medium hard wood, as well as in natural wood line that is used in joiner's workshops and carpentry businesses.	
11.1230 Ø mm 250-500 	Zuschnitt Kreissägeblatt · Tiefschnitt	Das ideale und preiswerte Blatt zum Erreichen hoher Schnitttiefen dank großem Zahnüberstand. Für grobe, schnelle und tiefe Zuschnitte in weich- und mittelharte Hölzer.	653
	Rip sawblade · Deep-cut	The ideal and inexpensive blade for reaching greater cutting depths thanks to the enlarged projection of the tooth. For rough, quick and deep cuts in soft and medium hard wood.	

1



2



3



4



5



6



7



8



9



10



Art.
100
101
102

Massivholz

Solid wood

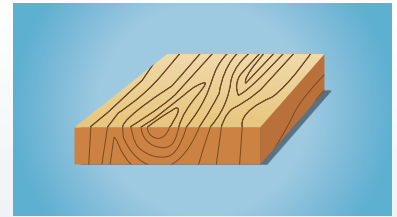

- 1
- 2
- 3
- 4
- 5
- 6
- 7
- 8
- 9
- 10

Art. Ø mm	Type	Anwendung · Application	
11.1232 Ø mm 250-500 	Zuschnitt/Vielblattkreissäge mit Räumerschneiden + Abweiser	Für Längs- und Querschnitte in Massivholz weich bis hart. Trocken bis naturfeucht. Ideal auch für tiefe Schnitte dank 3/4 x HM - Räumerschneiden. Flachzahn vorzugsweise für Längsschnitte.	654
	Rip/multi-rip sawblades with raker teeth + chip limiter	For longitudinal and cross cuts in soft to hard solid wood. Dry to natural moisture. Also ideal for deep cuts thanks to 3/4 x raker teeth. Flat tooth is preferable for longitudinal cuts.	
11.1235 Ø mm 300-500 	Zuschnitt/Vielblattkreissäge mit Räumerschneiden	Für Längs- und Querschnitte in Massivholz weich bis hart. Trocken bis naturfeucht. Ideal auch für tiefe Schnitte dank 3/4 x HM - Räumerschneiden.	655
	Rip/multi-rip sawblades with raker teeth	For longitudinal and cross cuts in soft to hard solid wood. Dry to natural moisture. Also ideal for deep cuts thanks to 3/4 x raker teeth.	
11.1238 Ø mm 250-450 	Vielblattkreissäge mit Räumerschneiden	Für Längsschnitte in Massivholz weich bis hart, naturfeucht bis nass.	656
	Multi-rip sawblades with raker teeth	For longitudinal cuts in solid wood soft to hard, naturally moist to wet.	
11.1239 Ø mm 250-400 	Vielblattkreissäge mit Räumerschneiden	Für Längsschnitte in Massivholz weich bis hart, naturfeucht bis nass.	657
	Multi-rip sawblades with raker teeth	For longitudinal cuts in solid wood soft to hard, naturally moist to wet.	

- Art.
100
101
102

Massivholz

Solid wood

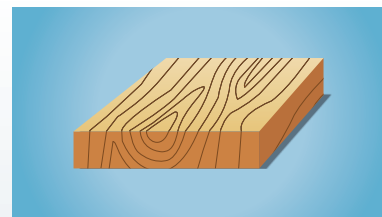

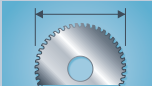
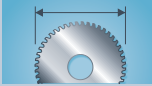
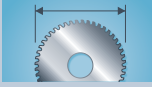
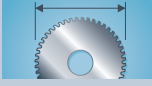
Art. Ø mm	Type	Anwendung · Application	
11.1300 Ø mm 150-800 	Massivholz Universal + Hundegger · Wechselzahn	Gute bis sehr gute Schnittqualität in alle Holzwerkstoffe, Massivholz längs und quer, 1- und 2-seitig Kunststoff/Furnier beschichtete Platten, Leisten, Furniere, Kunststoffe.	659
	Solid wood Universal + Hundegger · Alternate top bevel tooth	Good to very good cutting quality in all wooden materials, solid wood along and across the grain, panels and boards 1- and 2 sided plastic coated/veneered, strips and veneer, plastics.	
11.1320 Ø mm 200-500 	Massivholz Universal Plus · Wechselzahn + Achswinkel	Hervorragende und ausrissfreie Schnittqualität in alle Holzwerkstoffe, Massivholz quer, 1- und 2-seitig Kunststoff/Furnier beschichtet Platten, Leisten, Folien, Furniere, Kunststoffe (Thermoplast)	661
	Solid wood Universal Plus · Alternate Top Bevel tooth + Axial-Angle	Excellent, tear-free/splinter-free finishing-cut quality in all wooden materials, solid wood across the grain, panels and boards 1- and 2 sided plastic/veneer coated, strips, veneer, foils, plastics (Thermoplastics)	
11.1425 Ø mm 120-500 	Massivholz Universal · Wechselzahn · Dünnschnitt	Gute bis sehr gute Schnittqualität in alle Holzwerkstoffe, Massivholz längs und quer, 1- und 2-seitig Kunststoff/Furnier beschichtete Platten, Kunststoffprofile und Platten. Durch dünne Schnittbreite ideal auch für Akkumaschinen und für teure Edelhölzer, Furniere, Leisten da wenig Verschnitt und Schnittdruck/Akkuverbrauch.	663
	Solid wood Universal · Alternate Top Bevel tooth · Thin-Cut	Good to very good cutting quality in all wooden materials, solid wood along and across the grain, panels and boards 1- and 2 sided plastic coated/veneered, plastic profiles and boards. Due to thin-cut also ideal for battery machines and for cutting expensive precious wood, veneer, strips because of less waste/battery consumption.	
11.1450 Ø mm 210-600 	Kapp- und Gehrungssägeblätter · Wechselzahn/Negativ	Für Querschnitte in Weich- und Hartholz, Holzwerkstoffe, Leimholz, Schichtholz, Plattenwerkstoffe furniert oder beschichtet. Durch die negative Zahnform ist das Sägeblatt besser von Hand zu führen und wird nicht in das Schnittgut gezogen.	665
	Chop- and mitre circular saws · Alternate Top Bevel tooth/negative	For cross cuts in soft and hard wood, wooden materials, glued wood, plywood, veneered or coated boards. Due to the negative tooth shape, that saw blade can be guided easier by hand and is not pulled into the material to be cut.	

1



2



3



4



5



6



7



8



9



10



Art.
100
101
102

Art. **11.1200**

GOLD-STAR LINE 

Zuschnitt Kreissägeblatt · Wechselzahn mit Abweiser
Rip sawblade · Alternate top bevel tooth with chip limiter

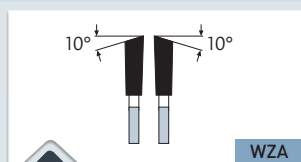
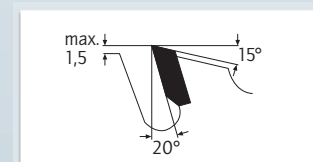
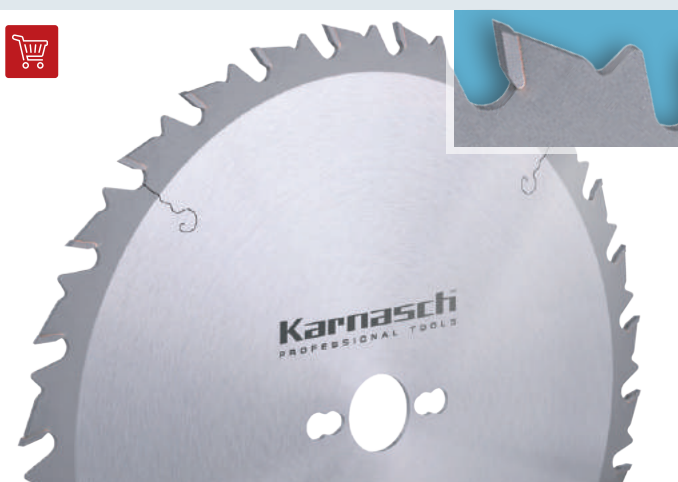





> Wechselzahn mit Abweiser
> Alternate top bevel tooth with chip limiter

MASCHINE · MACHINE

Für Tischkreissägen, Formatkreissägen, Wippkreissägen

For bench saws, sliding table saws, rocker saws





✓ OPTIMAL · OPTIMAL ✓ GUT · GOOD ✓ MÖGLICH · POSSIBLE

✓		Weichholz, Hartholz, Exotenholz, Quer	Soft wood, hard wood, and exotic wood across the grain
✓		Weichholz, Hartholz, Exotenholz Längs	Soft wood, hard wood, and exotic wood along the grain
✓		Leimholz, Tischler- und Furniersperrholz, Schichtholzplatten	Bonded wood, blockboard and veneer plywood, laminated wood
✓		Spanplatten, Hartfaserplatten, Platten ohne Belag LDF, MDF, HDF	Chipboard, hard fibre board, boards without laminate LDF, MDF, HDF

ANWENDUNG · APPLICATION

Für Zuschnitte in Weich- und Hartholz sowie für Brennholz, Bauhölzer, Schalungsplatten, Rohspanplatten. Ebenfalls für Trennschnitte in Holzplattenwerkstoffe (auch einseitig furniert oder mit Kunststoff belegt).

For ripping and cross cutting in soft and hard wood, as well as for cutting firewood, construction wood, plywood boards, raw chipboard. Also suitable for making cuts in wooden panels (also with veneer or plastic coating on one side).

Art.						€
111200.250.010	● 250	3,2/2,2	30	24 WZA	UNI	30,45
111200.280.010	● 280	3,2/2,2	30	28 WZA	UNI	35,85
111200.300.010	● 300	3,2/2,2	30	28 WZA	UNI	37,25
111200.315.010	● 315	3,2/2,2	30	28 WZA	UNI	41,15
111200.350.010	● 350	3,5/2,5	30	24 WZA	UNI	42,55
111200.350.020	● 350	3,5/2,5	30	32 WZA	UNI	46,45
111200.400.010	● 400	3,5/2,5	30	28 WZA	UNI	50,40
111200.400.020	● 400	3,5/2,5	30	36 WZA	UNI	52,35
111200.450.010	● 450	4,2/2,8	30	32 WZA	UNI	61,30
111200.450.020	● 450	4,2/2,8	30	40 WZA	UNI	67,00
111200.500.010	● 500	4,4/2,8	30	36 WZA	UNI	75,00
111200.500.020	● 500	4,4/2,8	30	44 WZA	UNI	78,05
111200.550.010	● 550	4,4/3,0	30	48 WZA	UNI	123,95
111200.600.010	● 600	4,4/3,0	30	40 WZA	UNI	129,80
111200.600.020	● 600	4,4/3,0	30	54 WZA	UNI	137,10
111200.700.010	● 700	4,4/3,2	30	46 WZA	UNI	147,70
111200.700.020	● 700	4,4/3,2	30	60 WZA	UNI	164,50
111200.800.010	▲ 800	4,8/3,6	30	60 WZA	UNI	437,10

UNI = 2-7-42 + 2-9-46,40 + 2-10-60

Blätter für tiefe Schnitte, siehe Art. 11.1215 Seite 651, Art. 11.1220 Seite 652, Art. 11.1235 Seite 655, Art. 11.1230 Seite 653 sowie Art. 11.1232 Seite 654

Blades for deep cuts see item 11.1215 page 651, item 11.1220 page 652, item 11.1235 page 655, item 11.1230 page 653 and item 11.1232 page 654



Video 

1



2



3



4



5



6



7



8



9



10



Art. 100 101 102

Zuschnitt Kreissägeblatt · Wechselzahn
Rip sawblade · Alternate top bevel tooth

Art. 11.1215

GOLD-STAR LINE

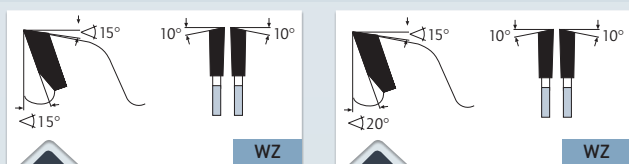

> Ø 150-230 mm Wechselzahn
> Ø 150-230 mm Alternate top bevel

> Ø 250-500 mm Wechselzahn
> Ø 250-500 mm Alternate top bevel

MASCHINE · MACHINE

Für Tischkreissägen, Formatkreissägen

For bench saws, sizing saws

✓ OPTIMAL · OPTIMAL ✓ GUT · GOOD ✓ MÖGLICH · POSSIBLE

✓		Weichholz, Hartholz, Exotenholz, Quer	Soft wood, hard wood, and exotic wood across the grain
✓		Weichholz, Hartholz, Exotenholz Längs	Soft wood, hard wood, and exotic wood along the grain
✓		Leimholz, Tischler- und Furniersperrholz, Schichtholzplatten	Bonded wood, blockboard and veneer plywood, laminated wood
✓		Spanplatten, Hartfaserplatten, Platten ohne Belag LDF, MDF, HDF	Chipboard, hard fibre board, boards without laminate LDF, MDF, HDF

ANWENDUNG · APPLICATION

Für Zuschnitte in Weich- und Hartholz sowie für Brennholz, Bauhölzer, Schalungsplatten, Rohspanplatten. Ebenfalls für Trennschnitte in Holzplattenwerkstoffe (auch einseitig furniert oder mit Kunststoff belegt). **Generell für Massivholzbearbeitung auch nass.**

For ripping and cross cutting in soft and hard wood, as well as for cutting firewood, construction wood, plywood boards, raw chipboard. Also suitable for making cuts in wooden panels (also with veneer or plastic coating on one side). **In general for solid wood. Also Wet.**

Art.						€
111215.150.010	• 150	3,2/2,2	30	24 WZ	UNI	29,25
-	• 160-170	Siehe/See Art. 11.1400, Seite/Page 667				
111215.180.010	• 180	3,2/2,2	30	30 WZ	UNI	33,35
-	• 190	Siehe/See Art. 11.1400, Seite/Page 667				
111215.200.010	• 200	3,2/2,2	30	36 WZ	UNI	42,20
-	• 210-225	Siehe/See Art. 11.1400, Seite/Page 668				
111215.230.010	• 230	3,2/2,2	30	24 WZ	UNI	30,45
-	• 240	Siehe/See Art. 11.1400, Seite/Page 668				
111215.250.010	• 250	3,2/2,2	30	24 WZ	UNI	30,45
111215.250.020	• 250	3,2/2,2	30	30 WZ	UNI	33,35
111215.255.010	• 255	3,2/2,2	30	24 WZ	UNI	30,45
-	• 260-280	Siehe/See Art. 11.1400, Seite/Page 668				
111215.300.010	• 300	3,2/2,2	30	24 WZ	UNI	37,10
111215.300.020	• 300	3,2/2,2	30	36 WZ	UNI	45,15
111215.315.010	• 315	3,2/2,2	30	24 WZ	UNI	40,60
111215.315.020	• 315	3,2/2,2	30	36 WZ	UNI	49,45
-	• 320-335	Siehe/See Art. 11.1400, Seite/Page 668				
111215.350.010	• 350	3,5/2,5	30	24 WZ	UNI	41,15
111215.350.020	• 350	3,5/2,5	30	32 WZ	UNI	45,85
111215.350.030	▲ 350	3,5/2,5	30	36 WZ	UNI	49,75
111215.350.040	• 350	3,5/2,5	30	42 WZ	UNI	53,35
-	• 355	Siehe/See Art. 11.1400, Seite/Page 668				
111215.370.010	• 370	4,2/2,5	30	26 WZ	UNI	53,05
111215.400.010	• 400	3,5/2,5	30	28 WZ	UNI	53,35
111215.400.020	• 400	3,5/2,5	30	36 WZ	UNI	59,70
111215.400.030	• 400	3,5/2,5	30	48 WZ	UNI	63,70
111215.410.010	• 410	4,2/2,5	30	28 WZ	UNI	62,25
111215.450.010	• 450	4,2/2,8	30	40 WZ	UNI	66,65
111215.500.010	• 500	4,2/2,8	30	44 WZ	UNI	79,95

UNI = 2-7-42 + 2-9-46,40 + 2-10-60

Blätter mit höherer Zähnezahl siehe Art. 11.1300 Seite 659
Blades with more teeth, see item 11.1300 page 659

Blätter für tiefe Schnitte, siehe Art. 11.1230 Seite 653 sowie Artikel 11.1232 Seite 654
Blades for deep cuts see item 11.1230 page 653, or item 11.1232 page 654



Video



651



10
Art.
100
101
102

Art. **11.1220**

GOLD-STAR LINE 

Zuschnitt Kreissägeblatt · Flachzahn mit Abweiser
Rip sawblade · Flat tooth with chip limiter

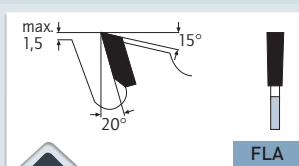





> Flachzahn mit Abweiser
> Flat tooth with chip limiter

MASCHINE · MACHINE

Für Tischkreissägen, Formatkreissägen

For bench saws, sizing saws





✓ OPTIMAL · OPTIMAL ✓ GUT · GOOD ✓ MÖGLICH · POSSIBLE

✓		Weichholz, Hartholz, Exotenholz Längs	Soft wood, hard wood, and exotic wood along the grain
✓		Weichholz, Hartholz, Exotenholz, Quer	Soft wood, hard wood, and exotic wood across the grain
✓		Leimholz, Tischler- und Furnier- sperrholz, Schichtholzplatten	Bonded wood, blockboard and veneer plywood, laminated wood
✓		Spanplatten, Hartfaserplatten, Platten ohne Belag LDF, MDF, HDF	Chipboard, hard fibre board, boards without laminate LDF, MDF, HDF

ANWENDUNG · APPLICATION

Für grobe und schnelle Zuschnitte in weich- und mittelharten Hölzern sowie Naturhölzern wie sie in Tischlereien und Zimmereigeschäften verwendet werden. Vorzugsweise für Längsschnitte. (Querschnitte ebenfalls möglich)

For rough and quick cuts in soft and medium hard wood, as well as in natural wood, like that used in joiner's workshops and carpentry businesses. Particularly suitable for longitudinal cuts. (Cross cuts are also possible).

Art.						€
111220.250.010	● 250	3,2/2,2	30	12 FLA	UNI	27,10
111220.300.010	● 300	3,2/2,2	30	14 FLA	UNI	29,85
111220.300.020	● 300	3,2/2,2	30	20 FLA	UNI	36,30
111220.315.010	▲ 315	3,2/2,2	30	20 FLA	2-7-42	38,10
111220.350.010	● 350	3,5/2,5	30	16 FLA	UNI	40,00
111220.350.020	● 350	3,5/2,5	30	24 FLA	UNI	41,15
111220.400.010	● 400	3,5/2,5	30	18 FLA	UNI	50,70
111220.400.020	● 400	3,5/2,5	30	28 FLA	UNI	53,35

UNI = 2-7-42 + 2-9-46,40 + 2-10-60

Weitere Trenn- und Zuschnitt grob-Blätter siehe Art. 11.1200 Seite 650, Art. 11.1215 Seite 651, Art. 11.1230 Seite 653, Art. 11.1232 Seite 654, Art. 11.1235 Seite 655

For more cutting and sizing coarse blades, see item 11.1200 page 650, item 11.1215 page 651, item 11.1230 page 653, item 11.1232 page 654, item 11.1235 page 655



Video 

1



2



3



4



5



6



7



8



9



10



Art.
100
101
102



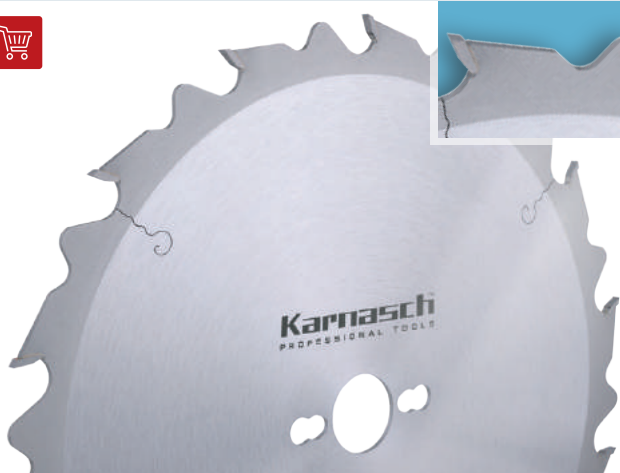

Zuschnitt Kreissägeblatt · Tiefschnitt
Rip sawblade · Deep-cut

Art. **11.1230**

GOLD-STAR LINE 



✓ OPTIMAL · OPTIMAL ✓ GUT · GOOD ✓ MÖGLICH · POSSIBLE

✓		Weichholz, Hartholz, Exotenholz Längs	Soft wood, hard wood, and exotic wood along the grain
✓		Weichholz, Hartholz, Exotenholz, Quer	Soft wood, hard wood, and exotic wood across the grain
✓		Leimholz, Tischler- und Furnier- sperrholz, Schichtholzplatten	Bonded wood, blockboard and veneer plywood, laminated wood
✓		Spanplatten, Hartfaserplatten, Platten ohne Belag LDF, MDF, HDF	Chipboard, hard fibre board, boards without laminate LDF, MDF, HDF

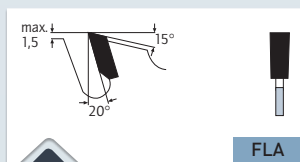

FLA

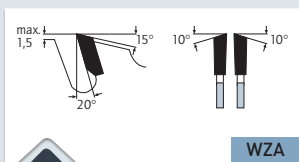

WZA

> Flachzahn mit Abweiser
> Flat tooth with chip limiter

> Wechselzahn mit Abweiser
> Alternate top bevel with chip limiter

MASCHINE · MACHINE





Für Tischkreissägen, Formatkreissägen

For bench saws, sizing saws

ANWENDUNG · APPLICATION

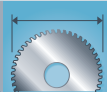
Das ideale und preiswerte Blatt zum Erreichen hoher Schnitttiefen dank großem Zahnüberstand. Für grobe, schnelle und tiefe Zuschnitte in weich- und mittelharten Hölzern. Trocken bis naturfeucht. Flachzahn (FLA) Ausführung vorzugsweise für Langsschnitte.

The ideal and inexpensive blade for reaching greater cutting depths thanks to the enlarged projection of the tooth. For rough, quick and deep cuts in soft and medium hard wood. Dry to natural moisture. Flat tooth (FLA) design preferably for cuts along the grain.

Art.						€
111230.250.010	● 250	3,6/2,2	30	12 FLA	UNI	30,80
111230.250.020	● 250	3,6/2,2	30	16 WZA	UNI	32,75
111230.300.010	● 300	3,8/2,2	30	14 FLA	UNI	33,00
111230.300.020	● 300	3,8/2,2	30	18 WZA	UNI	39,90
111230.350.010	● 350	4,2/2,5	30	16 FLA	UNI	43,35
111230.350.020	● 350	4,2/2,5	30	20 WZA	UNI	45,65
111230.400.010	● 400	4,4/2,8	30	18 FLA	UNI	56,90
111230.400.020	● 400	4,4/2,8	30	24 WZA	UNI	62,70
111230.450.010	● 450	4,5/2,8	30	20 FLA	UNI	66,70
111230.450.020	● 450	4,5/2,8	30	28 WZA	UNI	75,10
111230.500.010	● 500	4,5/2,8	30	24 FLA	UNI	77,40
111230.500.020	● 500	4,5/2,8	30	32 WZA	UNI	87,90

UNI = 2-7-42 + 2-9-46,40 + 2-10-60

Weitere Trenn- und Zuschnitt grob-Blätter siehe Art. 11.1200 Seite 650, Art. 11.1215 Seite 651, Art. 11.1220 Seite 652, Art. 11.1232 Seite 654, Art. 11.1235 Seite 655

For more cutting and sizing coarse blades, see item 11.1200 page 650, item 11.1215 page 651, item 11.1220 page 652, item 11.1232 page 654, item 11.1235 page 655



Video



653



10
Art.
100
101
102

Karnasch® HARTMETALL-BESTÜCKTE KREISSÄGEBLÄTTER CARBIDE TIPPED CIRCULAR SAW BLADES

Art. **11.1232**



Zuschnitt/Vielblatt Kreissäge mit Räumerschneiden + Abweiser
Rip/multi-rip sawblade with raker teeth + chip limiter

B = Innenliegende HM-bestückte
Räumerschneiden
Inner T.C.T.
raker teeth

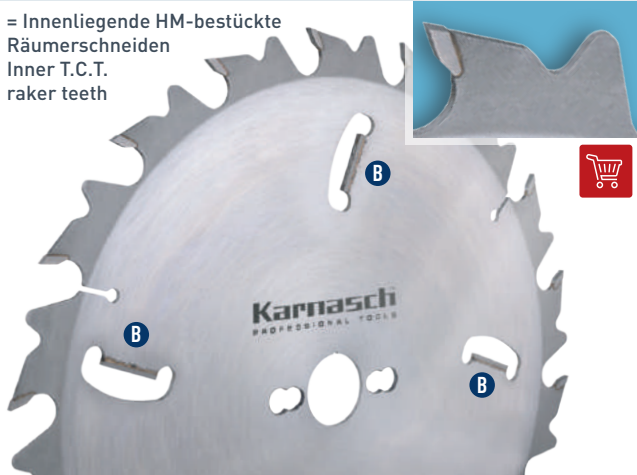

✓ OPTIMAL · OPTIMAL ✓ GUT · GOOD ✓ MÖGLICH · POSSIBLE

✓		Weichholz, Hartholz, Exotenholz Längs	Soft wood, hard wood, and exotic wood along the grain
✓		Weichholz, Hartholz, Exotenholz, Quer	Soft wood, hard wood, and exotic wood across the grain
✓		Leimholz, Tischler- und Furnier- sperrholz, Schichtholzplatten	Bonded wood, blockboard and veneer plywood, laminated wood
✓		Spanplatten, Hartfaserplatten, Platten ohne Belag LDF, MDF, HDF	Chipboard, hard fibre board, boards without laminate LDF, MDF, HDF

ANWENDUNG · APPLICATION

Für Längs- und Querschnitte in Massivholz weich bis hart. Trocken bis natur-
feucht. Ideal auch für tiefe Schnitte dank 3/4 x HM - Räumerschneiden. Flachzahn
vorzugsweise für Längsschnitte.

For longitudinal and cross cuts in soft to hard solid wood. Dry to natural moisture.
Also ideal for deep cuts thanks to 3/4 x raker teeth. Flat tooth is preferable for
longitudinal cuts.

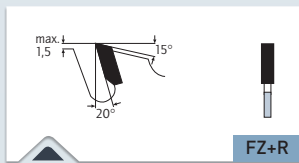

FZ+R

> Flachzahn mit Abweiser + Räumerschneiden
> Flat tooth with chip thickness limiter + raker
teeth

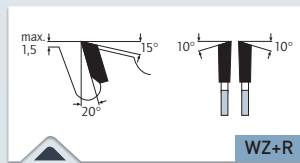

WZ+R

> Wechselzahn mit Abweiser + Räumerschneiden
> Alternate tooth with chip thickness limiter +
raker teeth

MASCHINE · MACHINE

Für Formatmaschinen, Tischkreissägen, Zimmerei-Handkreissägen,
Säumer, Mehrblatt-Abbundanlagen. Manueller oder automatischer
Vorschub.

For sizing saws, bench saws, Carpentry portable circular saws,
seamers, multi-rip, joining saws. Manual or automatic feed.

Art.							MAXIMALER FLANSCH Ø MAXIMUM FLANGE Ø	MAXIMALE SCHNITTtiefe MAXIMUM DEPTH OF CUT	€
111232.250.010	• 250	3,2/2,2	30	18 FZ+R	3x B	UNI	115mm	60mm	58,75
111232.300.010	• 300	3,2/2,2	30	18 FZ+R	3x B	UNI	130mm	75mm	67,50
111232.300.020	• 300	3,6/2,5	30	18 WZ+R	4x B	UNI	130mm	75mm	79,00
111232.350.010	• 350	3,6/2,5	30	20 FZ+R	4x B	UNI	105mm	100mm	89,25
111232.350.020	• 350	3,6/2,5	30	24 WZ+R	4x B	UNI	105mm	100mm	93,00
111232.400.010	• 400	4,0/2,8	30	24 FZ+R	4x B	UNI	120mm	120mm	100,10
111232.400.020	• 400	4,0/2,8	30	28 WZ+R	4x B	UNI	120mm	120mm	107,55
111232.450.010	• 450	4,2/2,8	30	28 FZ+R	4x B	UNI	170mm	140mm	135,85
111232.450.020	• 450	4,0/2,8	30	36 WZ+R	4x B	UNI	170mm	140mm	138,05
111232.500.010	• 500	4,4/3,2	30	32 FZ+R	4x B	UNI	180mm	155mm	165,80

UNI = 2-7-42 + 2-9-46,40 + 2-10-60

Weitere Abmessungen auf Anfrage
Other dimensions are available on request



Art.
100
101
102

Zuschnitt/Vielblatt Kreissäge mit Räumerschneiden
Rip/multi-rip sawblade with raker teeth

Art. 11.1235

GOLD-STAR LINE

B = Innenliegende HM-bestückte
Räumerschneiden
Inner T.C.T.
raker teeth

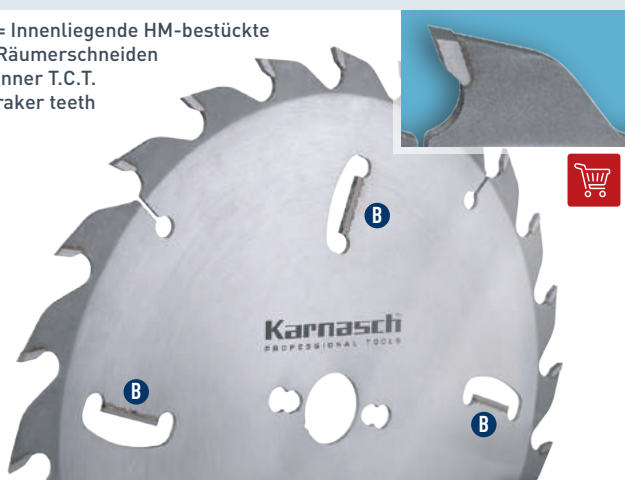

✓ OPTIMAL · OPTIMAL ✓ GUT · GOOD ✓ MÖGLICH · POSSIBLE

✓		Weichholz, Hartholz, Exotenholz Längs	Soft wood, hard wood, and exotic wood along the grain
✓		Weichholz, Hartholz, Exotenholz, Quer	Soft wood, hard wood, and exotic wood across the grain
✓		Leimholz, Tischler- und Furnier- sperrholz, Schichtholzplatten	Bonded wood, blockboard and veneer plywood, laminated wood
✓		Spanplatten, Hartfaserplatten, Platten ohne Belag LDF, MDF, HDF	Chipboard, hard fibre board, boards without laminate LDF, MDF, HDF

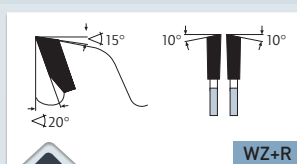

> Wechselzahn + Räumerschneiden
> Alternate tooth + raker teeth

ANWENDUNG · APPLICATION

Für Längs- und Querschnitte in Massivholz weich bis hart. Trocken bis natur-
feucht. Ideal auch für tiefe Schnitte dank 3/4 x HM - Räumerschneiden.

For longitudinal and cross cuts in soft to hard solid wood. Dry to natural moisture.
Also ideal for deep cuts thanks to 3/4 x raker teeth.

MASCHINE · MACHINE

Für Formatmaschinen, Tischkreissägen, Zimmerei-Handkreissägen,
Säumer, Mehrblatt-Abbundanlagen. Manueller oder automatischer
Vorschub.

For sizing saws, bench saws, Carpentry portable circular saws, seamers,
multi-rip, joining saws. Manual or automatic feed.

Art.							MAXIMALER FLANSCH Ø MAXIMUM FLANGE Ø	MAXIMALE SCHNITTIEFE MAXIMUM DEPTH OF CUT	€
111235.300.010	• 300	3,4/2,2	30	24 WZ+R	4x B	UNI	130mm	60mm	83,20
111235.350.010	• 350	3,6/2,5	30	32 WZ+R	4x B	UNI	105mm	100mm	103,65
111235.400.010	• 400	4,0/2,8	30	36 WZ+R	4x B	UNI	120mm	120mm	122,65
111235.450.010	• 450	4,2/2,8	30	40 WZ+R	4x B	UNI	170mm	140mm	138,90
111235.500.010	• 500	4,4/3,2	30	44 WZ+R	4x B	UNI	180mm	155mm	168,85

UNI = 2-7-42 + 2-9-46,40 + 2-10-60

Weitere Abmessungen auf Anfrage
Other dimensions are available on request

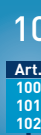

Video

655

Art.
100
101
102

Art. **11.1238**

Vielblatt Kreissägen mit Räumerschneiden
Multi-rip sawblades with raker teeth

GOLD-STAR LINE 

A = Außenliegende HM-bestückte Räumerschneiden
Outer T.C.T raker teeth

B = Innenliegende HM-bestückte Räumerschneiden
Inner T.C.T raker teeth



✓ OPTIMAL · OPTIMAL ✓ GUT · GOOD ✓ MÖGLICH · POSSIBLE

✓  Weichholz, Hartholz, Exotenholz Längs
Soft wood, hard wood, and exotic wood along the grain

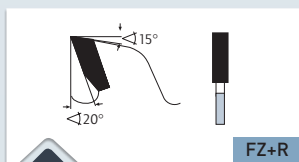

> Flachzahn mit Räumerschneiden
> Flat tooth with raker teeth

ANWENDUNG · APPLICATION

Für Längsschnitte in Massivholz weich bis hart, naturfeucht bis nass.

For longitudinal cuts in solid wood soft to hard, naturally moist to wet.

MASCHINE · MACHINE

Ein- oder Doppelwellige Vielblattkreissägen, Besäumkreissägen

Single- or double-shaft multi-blade circular saw, trimming circular saw

Art.						MAXIMALER FLANSCH Ø MAXIMUM FLANGE Ø	MAXIMALE SCHNITTtiefe MAXIMUM DEPTH OF CUT	€
111238.250.010	• 250	3,2/2,2	Ø=70 / 1=13x5 / 2=20x6,5	16 FZ+R	2x A + 2x B	105mm	65mm	65,30
111238.250.020	• 250	3,2/2,2	Ø=80 / 1=14x5 / 2=22x6,5	16 FZ+R	2x A + 2x B	105mm	65mm	65,30
111238.300.010	• 300	3,2/2,2	Ø=70 / 1=13x5 / 2=20x6,5	18 FZ+R	2x A + 2x B	120mm	85mm	69,65
111238.300.020	• 300	3,2/2,2	Ø=80 / 1=14x5 / 2=22x6,5	18 FZ+R	2x A + 2x B	120mm	85mm	69,65
111238.300.030	• 300	3,2/2,2	Ø=30,UNI	24 FZ+R	2x A + 2x B	120mm	85mm	75,15
111238.315.010	• 315	3,2/2,2	Ø=70 / 1=13x5 / 2=20x6,5	18 FZ+R	2x A + 2x B	120mm	90mm	82,70
111238.315.020	• 315	3,2/2,2	Ø=80 / 1=14x5 / 2=22x6,5	18 FZ+R	2x A + 2x B	120mm	90mm	82,70
111238.350.010	• 350	3,6/2,5	Ø=70 / 1=13x5 / 2=20x6,5	20 FZ+R	2x A + 2x B	120mm	110mm	87,05
111238.350.020	• 350	3,6/2,5	Ø=80 / 1=14x5 / 2=22x6,5	20 FZ+R	2x A + 2x B	120mm	110mm	87,05
111238.350.030	• 350	3,6/2,5	Ø=30,UNI	24 FZ+R	2x A + 2x B	120mm	110mm	91,40
111238.400.010	• 400	4,0/2,8	Ø=70 / 1=13x5 / 2=20x6,5	24 FZ+R	2x A + 2x B	145mm	120mm	97,10
111238.400.020	• 400	4,0/2,8	Ø=80 / 1=14x5 / 2=22x6,5	24 FZ+R	2x A + 2x B	145mm	120mm	97,10
111238.450.010	• 450	4,4/3,2	Ø=70 / 1=13x5 / 2=20x6,5	28 FZ+R	2x A + 2x B	160mm	140mm	132,20
111238.450.020	• 450	4,4/3,2	Ø=80 / 1=14x5 / 2=22x6,5	28 FZ+R	2x A + 2x B	160mm	140mm	132,20

2-7-42 + 2-9-46,40 + 2-10-60

Weitere Abmessungen auf Anfrage
Other dimensions are available on request



Art. 100 101 102

Vielblatt Kreissägen mit Rämerschneiden
Multi-rip sawblades with raker teeth

Art. 11.1239

GOLD-STAR LINE

A = Außenliegende HM-bestückte
Rämerschneiden
Outer T.C.T
raker teeth



✓ OPTIMAL · OPTIMAL ✓ GUT · GOOD ✓ MÖGLICH · POSSIBLE

✓  Weichholz, Hartholz, Exotenholz
Längs Soft wood, hard wood, and exotic
wood along the grain

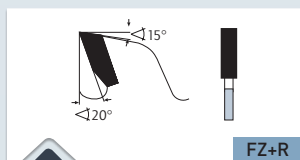
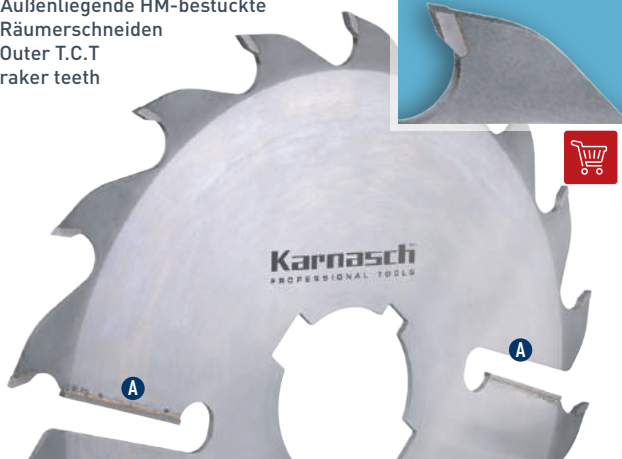

> Flachzahn mit Rämerschneiden
> Flat tooth with raker teeth

MASCHINE · MACHINE





Ein- oder Doppelwellige Vielblattkreissägen, Besäumkreissägen

Single- or double-shaft multi-blade circular saw, trimming circular saw

ANWENDUNG · APPLICATION

Für Längsschnitte in Massivholz weich bis hart, naturfeucht bis nass.

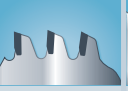
For longitudinal cuts in solid wood soft to hard, naturally moist to wet.

Art.						MAXIMALER FLANSCH Ø MAXIMUM FLANGE Ø	MAXIMALE SCHNITTIEFE MAXIMUM DEPTH OF CUT	€
111239.250.010	• 250	3,6/2,5	Ø=70 / ①=13x5 / ②=20x6,5	16 FZ+R	2x A	130mm	50mm	51,20
111239.250.020	• 250	3,6/2,5	Ø=80 / ①=14x5 / ②=22x6,5	16 FZ+R	2x A	130mm	50mm	51,20
111239.300.010	• 300	4,0/2,8	Ø=70 / ①=13x5 / ②=20x6,5	18 FZ+R	2x A	130mm	70mm	67,50
111239.300.020	• 300	4,0/2,8	Ø=80 / ①=14x5 / ②=22x6,5	18 FZ+R	2x A	130mm	70mm	67,50
111239.350.010	• 350	4,0/2,8	Ø=70 / ①=13x5 / ②=20x6,5	20 FZ+R	2x A	135mm	100mm	78,35
111239.350.020	• 350	4,0/2,8	Ø=80 / ①=14x5 / ②=22x6,5	20 FZ+R	2x A	135mm	100mm	78,35
111239.400.010	• 400	4,0/2,8	Ø=70 / ①=13x5 / ②=20x6,5	24 FZ+R	2x A	185mm	110mm	90,80
111239.400.020	• 400	4,0/2,8	Ø=80 / ①=14x5 / ②=22x6,5	24 FZ+R	2x A	185mm	110mm	90,80

Weitere Abmessungen auf Anfrage
Other dimensions are available on request



Video

657

Art.
100
101
102

Karnasch® HARTMETALL-BESTÜCKTE KREISSÄGEBLÄTTER CARBIDE TIPPED CIRCULAR SAW BLADES

Art. **11.1300**

GOLD-STAR LINE 

Massivholz Universal + Hundegger · Wechselzahn

Solid wood universal + Hundegger · Alternate top bevel tooth

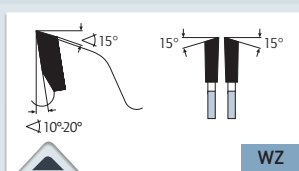











> Wechselzahn
> Alternate top bevel

MASCHINE · MACHINE

Für Tisch- und Formatkreissägen, Kappkreissägen sowie für Hundegger Abbundanlagen.

For bench and panel sizing saws, cross cut saws, Hundegger trimming machines.

✓ OPTIMAL · OPTIMAL ✓ GUT · GOOD ✓ MÖGLICH · POSSIBLE

✓		Weichholz, Hartholz, Exotenholz, Quer	Soft wood, hard wood, and exotic wood across the grain
✓		Weichholz, Hartholz, Exotenholz Längs	Soft wood, hard wood, and exotic wood along the grain
✓		Leimholz, Tischler- und Furniersperrholz, Schichtholzplatten	Bonded wood, blockboard and veneer plywood, laminated wood
✓		Spanplatten, Hartfaserplatten, Platten ohne Belag LDF, MDF, HDF	Chipboard, hard fibre board, boards without laminate LDF, MDF, HDF
✓		Spanplatten, Hartfaserplatten Kunststoff beschichtet/furniert, MDF, HDF	Chipboard, hard fibre board, plastic-coated/veneered, MDF, HDF
✓		Furniere	Veneers
✓		Profileleisten	Profiled wood
✓		Mineralische/acrylgebundene Massivplatten/Küchenplatten: Corian®, Noblan®, Hi-Macs®, Staron®, Rausolid®, Varicor®	Mineral/acrylic bound solid boards/kitchen worktops: Corian®, Noblan®, Hi-Macs®, Staron®, Rausolid®, Varicor®
✓		HPL-Duroplastische Schichtstoffplatten/Fassadenplatten: Trespa®, Resopal®, Duropal®, Formica®, Kronospan®, Decodur®	HPL High-Pressure-Laminate solid boards/façade panels: Trespa®, Resopal®, Duropal®, Formica®, Kronospan®, Decodur®
✓		Kunststoffe, Plexiglas, Duro- und Thermoplaste	Plastics, plexiglass, acrylics, duro- and thermoplastics
✓		Gips-Zement-Steinwollplatten, Eternit, GFK, CFK, HPL, Mineralwerkstoffe	Gypsum/Cement fibre boards, Rockwool, Eternit, GRP, CFK, HPL, Mineral material

ANWENDUNG · APPLICATION

Geringere Zähnezahlen: Gute Schnittqualität in alle Holzwerkstoffe, Massivholz längs- und quer, Plattenwerkstoffe einseitig furniert oder beschichtet, Hartgewebe, Hartpapiere sowie für dickere Kunststoffplatten/Profile (Thermoplast).

Höhere Zähnezahlen: Sehr gute Schnittqualität in alle Holzwerkstoffe, Massivholz vorzugsweise quer, Plattenwerkstoffe zweiseitig furniert oder beschichtet (ggf. Vorritzer verwenden), Hartgewebe, Hartpapier, Leisten und Furnier, Kunststoff (Thermoplaste, Duroplaste).

Für exzellente Schnittgüte aller Holzwerkstoffe massiv sowie Platten beschichtet/ furniert auch auf der Unterseite ohne Vorritzer siehe Art. 11.1320 Seite 661

Lower number of teeth: Good cutting quality in all wooden materials, solid wood across and along the grain, panels and boards one-sided plastic coated/veneered, paper-based laminate, thicker plastic boards/profiles (thermoplastics).

Higher number of teeth: Very good cutting quality in all wooden materials, solid wood across and along the grain, panels and boards two-sided plastic coated/veneered (if applicable with scorer), paper-based laminate, strips and veneer, plastics (thermoplastics, duroplastics)

For excellent cutting in all wooden materials, solid wood an panels/boards two-sided plastic coated/veneered (also without using scorer) see art. 11.1320 page 661



Video



1

2

3

4

5

6

7

8

9

10

11

12

13

14

15

16

17

18

19

20

21

22

23

24

25

26

27

28

29

30

31

32

33

34

35

36

37

38

39

40

41

42

43

44

45

46

47







48

Art.
100
101
102







Massivholz Universal + Hundegger · Wechselzahn
Solid wood universal + Hundegger · Alternate top bevel tooth

Art. **11.1300**

GOLD-STAR LINE 

Art.								€
111300.150.010	● 150	3,2/2,2	30	36 WZ	10	UNI	-	34,00
111300.180.010	● 180	3,2/2,2	30	42 WZ	10	UNI	-	39,90
111300.200.010	● 200	3,2/2,2	30	48 WZ	10	UNI	-	45,60
111300.230.010	● 230	3,2/2,2	30	48 WZ	15	UNI	-	47,50
111300.250.010	● 250	3,2/2,2	30	40 WZ	15	UNI	✓	47,25
111300.250.020	● 250	3,2/2,2	30	48 WZ	15	UNI	✓	51,55
111300.250.030	● 250	3,2/2,2	30	60 WZ	10	UNI	✓	60,15
111300.250.040	● 250	3,2/2,2	30	80 WZ	10	UNI	✓	70,00
111300.300.010	● 300	3,2/2,2	30	48 WZ	15	UNI	✓	58,00
111300.300.020	● 300	3,2/2,2	30	60 WZ	15	UNI	✓	67,20
111300.300.030	● 300	3,2/2,2	30	72 WZ	10	UNI	✓	73,30
111300.300.040	● 300	3,2/2,2	30	96 WZ	10	UNI	✓	88,15
111300.305.010	● 305	3,2/2,2	30	48 WZ	15	UNI	✓	58,00
111300.305.020	● 305	3,2/2,2	30	60 WZ	15	UNI	✓	67,20
111300.305.030	● 305	3,2/2,2	30	72 WZ	10	UNI	✓	73,30
111300.315.010	● 315	3,2/2,2	30	48 WZ	15	UNI	✓	65,40
111300.315.020	● 315	3,2/2,2	30	60 WZ	15	UNI	✓	76,50
111300.315.030	● 315	3,2/2,2	30	72 WZ	10	UNI	✓	79,45
111300.315.040	● 315	3,2/2,2	30	96 WZ	10	UNI	✓	97,20
111300.350.010	● 350	3,5/2,5	30	54 WZ	15	UNI	✓	74,05
111300.350.020	● 350	3,5/2,5	30	72 WZ	15	UNI	✓	86,15
111300.350.030	● 350	3,5/2,5	30	84 WZ	10	UNI	✓	92,35
111300.350.040	● 350	3,5/2,5	30	108 WZ	10	UNI	✓	103,50
111300.370.010	● 370	4,2/2,5	30	60 WZ	15	UNI	✓	93,70
111300.400.010	● 400	3,5/2,5	30	60 WZ	15	UNI	✓	88,95
111300.400.020	● 400	3,5/2,5	30	84 WZ	15	UNI	✓	102,45
111300.400.030	● 400	3,5/2,5	30	96 WZ	10	UNI	✓	111,90
111300.400.040	● 400	3,5/2,5	30	120 WZ	10	UNI	✓	117,50
111300.410.010	● 410	4,2/2,5	30	60 WZ	15	UNI	✓	104,55
111300.450.010	● 450	4,0/2,8	30	66 WZ	15	UNI	✓	109,50
111300.450.020	● 450	4,0/2,8	30	84 WZ	15	UNI	✓	126,55
111300.450.030	● 450	4,0/2,8	30	108 WZ	10	UNI	✓	143,35
111300.450.040	● 450	4,0/2,8	30	132 WZ	10	UNI	✓	171,70
111300.500.010	● 500	4,0/2,8	30	60 WZ	20	UNI+2-10-80	✓	120,60
111300.500.020	● 500	4,0/2,8	30	72 WZ	15	UNI+2-10-80	✓	134,70
111300.500.030	● 500	4,0/2,8	30	96 WZ	15	UNI+2-10-80	✓	158,40
111300.500.040	● 500	4,0/2,8	30	120 WZ	10	UNI+2-10-80	✓	181,75
111300.500.050	● 500	4,0/2,8	30	144 WZ	10	UNI+2-10-80	✓	201,95

SPEZIALPROGRAMM HUNDEGGER / SPECIAL SELECTION HUNDEGGER

Art.	Maschine Machine								€
111300.550.010	Zuschnitt-Automat Turbo-Drive	● 550	6,0/4,4	30	60 WZ	15	8-8,5-120 Angesenkt 2-13-240 Versetzt 22,5°	✓	309,05
111300.600.010		● 600	4,8/3,4	30	48 WZ	15	2-8,5-90+2-10-80+2-15-63	✓	267,25
111300.650.010		● 650	5,8/4,0	30	36 WZ	15	2-8,5-90+2-10-80+2-15-63	✓	293,65
111300.650.020		● 650	5,8/4,0	30	48 WZ	15	2-8,5-90+2-10-80+2-15-63	✓	323,65
111300.650.030		● 650	5,6/4,0	30	96 WZ	12	2-8,5-90+2-10-80+2-15-63	✓	344,00
111300.720.010	Zuschnitt-Automat SC-3	● 720	6,0/4,4	30	72 WZ	15	8-8,5-120 Angesenkt 4-8,1-90 Versetzt 2-14-400 Versetzt	✓	548,80
111300.720.020		● 720	6,0/4,4	30	48 WZ	15	2-8,5-90	✓	475,85
111300.720.030		● 720	6,0/4,4	30	72 WZ	15	2-8,5-90	✓	548,80
111300.735.010		● 735	6,0/4,4	30	72 WZ	15	2-8,5-90	✓	558,40
111300.760.010		● 760	6,0/4,4	30	72 WZ	15	4-8,5-90+2-15-415	✓	564,35
111300.800.010	Abbindmaschine Robot-Drive	● 800	6,0/4,4	30	72 WZ	15	8-8,5-160 Angesenkt 4-8,1-90 Versetzt 2-14-400 Versetzt	✓	569,50
111300.800.020		● 800	6,0/4,4	30	80 WZ	12	4-8,5-90+2-15-415	✓	594,10

Weitere Abmessungen Hundegger kurzfristig auf Anfrage lieferbar

Other sizes Hundegger available at short notice on request

UNI = 2-7-42 + 2-9-46,40 + 2-10-60

1



2



3



4



5



6



7



8



9



10



Art.
100
101
102

Art. **11.1320**





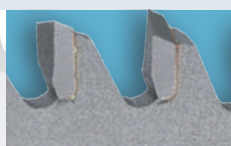
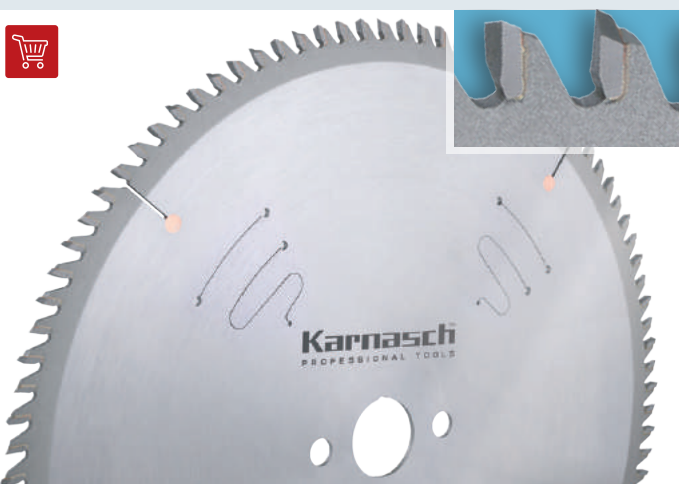

GOLD-STAR LINE 

Massivholz Universal Plus · Wechselzahn + Achswinkel

Solid wood universal plus · Alternate to bevel tooth + axial-angle



✓ OPTIMAL · OPTIMAL ✓ GUT · GOOD ✓ MÖGLICH · POSSIBLE

✓		Weichholz, Hartholz, Exotenholz, Quer	Soft wood, hard wood, and exotic wood across the grain
✓		Leimholz, Tischler- und Furniersperrholz, Schichtholzplatten	Bonded wood, blockboard and veneer plywood, laminated wood
✓		Spanplatten, Hartfaserplatten, Platten ohne Belag LDF, MDF, HDF	Chipboard, hard fibre board, boards without laminate LDF, MDF, HDF
✓		Spanplatten, Hartfaserplatten Kunststoff beschichtet/furniert, MDF, HDF	Chipboard, hard fibre board, plastic-coated/veneered, MDF, HDF
✓		Furniere	Veneers
✓		Profileleisten	Profiled wood
✓		Kunststoffe, Plexiglas, Duro- und Thermoplaste	Plastics, plexiglass, acrylics, duro- and thermoplastics

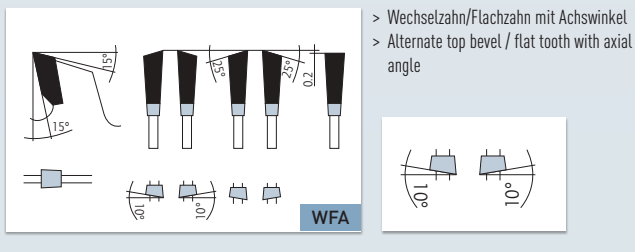

MASCHINE · MACHINE

Plattenaufteilsägen vertikal, Formatkreissägen, Doppelgehrungssägen, mechanische Kappsägemaschinen, Unterflurkappsägemaschinen, CNC-Bearbeitungszentren.

Vertical panel sizing saws, trimming saws, double mitre saws, mechanical chop saws, under frame mounted chop saws, machining centers with saw aggregate.

ANWENDUNG · APPLICATION

Formatieren von Holzwerkstoffen in hervorragender Fertigschnittqualität. **Ausriss-freies** Sägen von beschichteten Holzwerkstoffen auch mit sehr dicken Deckschichten, Massivholz quer, Kunststoffprofile, Kunststoffummantelte Leisten, Furnierte oder Folienummantelte Türzagen...

Panel sizing/trimming of wood-based material in excellent finishing-cut quality. **Splinter-free** sawing of laminated wood-based material including material with very thick top layers, solid wood across the grain, plastic profiles, synthetically coated ledges, veneered or foil-sheathed door frames...

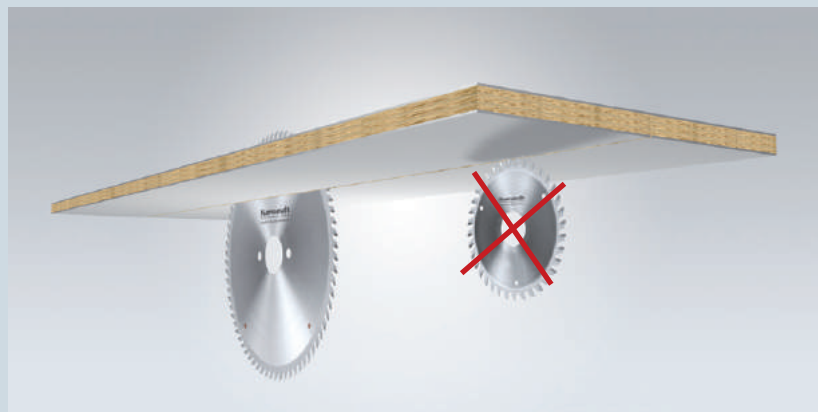

Ritzer nicht erforderlich

Scorer not required



Video



Art.
100
101
102

Massivholz Universal Plus · Wechselzahn + Achswinkel
Solid wood universal plus · Alternate to bevel tooth + axial-angle

Art. 11.1320

GOLD-STAR LINE 

Art.							€
111320.200.010	• 200	3,0/2,2	30	60 WFA	2-6,2-42 + 4-6-52 + 4-6,6-60	-	122,65
111320.220.010	• 220	3,0/2,2	30	70 WFA	UNI	-	130,65
111320.250.010	• 250	3,0/2,2	30	80 WFA	UNI	✓	141,40
111320.303.010	• 303	3,0/2,2	30	100 WFA	UNI	✓	171,45
111320.350.010	• 350	3,0/2,2	30	100 WFA	UNI	✓	188,75
111320.400.010	• 400	3,0/2,2	30	120 WFA	UNI	✓	229,60
111320.450.010	• 450	3,6/2,8	30	130 WFA	UNI	✓	256,55
111320.500.010	• 500	3,6/2,8	30	140 WFA	UNI	✓	284,35

UNI = 2-7-42 + 2-9-46,40 + 2-10-60

Arbeiten mit Sägewelle **unter** dem Werkstück
Working with spindle **under** the panel



Durch den positiven Spanwinkel wirkt der Schnittdruck über dem Werkstück auf die stabile Tischauflage.
Due to the positive cutting angle acts the cutting pressure above the panel into the stable saw table.

1



2



3



4



5



6



7



8



9



10



Art.
100
101
102

Art. **11.1425**

Massivholz Universal · Wechselzahn · Dünnschnitt
Solid wood universal · Alternate top bevel tooth · Thin-Cut

GOLD-STAR LINE 

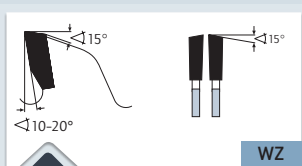









> Wechselzahn
> Alternate top bevel

MASCHINE · MACHINE

Für Handkreissägen, Tauchsägen, Tisch- und Formatkreissägen, Plattenaufteilsägen, Kappsägen, Akkusägen

For portable circular saws, table-and sizing saws, panel sizing saws, cross-cut saws, cordless saws.

✓ OPTIMAL · OPTIMAL ✓ GUT · GOOD ✓ MÖGLICH · POSSIBLE

✓		Weichholz, Hartholz, Exotenholz, Quer	Soft wood, hard wood, and exotic wood across the grain
✓		Profileleisten	Profiled wood
✓		Furniere	Veneers
✓		Spanplatten, Hartfaserplatten, Platten ohne Belag LDF, MDF, HDF	Chipboard, hard fibre board, boards without laminate LDF, MDF, HDF
✓		Spanplatten, Hartfaserplatten Kunststoff beschichtet/furniert, MDF, HDF	Chipboard, hard fibre board, plastic-coated/veneered, MDF, HDF
✓		Leimholz, Tischler- und Furniersperrholz, Schichtholzplatten	Bonded wood, blockboard and veneer plywood, laminated wood
✓		Kunststoffe, Plexiglas, Duro- und Thermoplaste	Plastics, plexiglass, acrylics, duro- and thermoplastics
✓		Mineralische/acrylgebundene Massivplatten/Küchenplatten: Corian®, Noblan®, Hi-Macs®, Staron®, Rausolid®, Varicor®	Mineral/acrylic bound solid boards/kitchen worktops: Corian®, Noblan®, Hi-Macs®, Staron®, Rausolid®, Varicor®
✓		HPL-Duroplastische Schichtstoffplatten/Fassadenplatten: Trespa®, Resopal®, Duropal®, Kronospan®, Decodur®	HPL High-Pressure-Laminate solid boards/face panels: Trespa®, Resopal®, Duropal®, Kronospan®, Decodur®

ANWENDUNG · APPLICATION

Durch dünne Schnittbreite ideal auch für Akkumaschinen und für teure Edelhölzer, Furniere und Leisten da wenig Verschnitt und Schnittdruck/Akkuverbrauch.

Niedere Zähnezahl: Grobe bis mittlere Schnittqualität in alle Holzwerkstoffe, Edelhölzer und Massivholz längs- und quer, Plattenwerkstoffe einseitig furniert oder Kunststoff beschichtet, Hartgewebe, Hartpapier, dickere Kunststoffprofile und Platten (Thermoplaste) Hoher Vorschub möglich.

Mittlere Zähnezahl: Gute Schnittqualität in alle Holzwerkstoffe, Edelhölzer, Massivholz und Leisten längs- und quer, Plattenwerkstoffe einseitig/zweiseitig furniert oder Kunststoff beschichtet, Hartgewebe, Hartpapier, Furnier und Furnierpakete sowie Kunststoffprofile und Platten (Thermoplaste, Duroplaste).

Hohe Zähnezahl: Sehr gute Schnittqualität in alle Holzwerkstoffe, Edelhölzer, Massivholz und Leisten vorzugsweise Querschnitte. Plattenwerkstoffe zweiseitig furniert oder Kunststoff beschichtet, Hartgewebe, Hartpapier, Furnier und Furnierpakete sowie Kunststoffprofile und Platten (Thermoplaste, Duroplaste).

Durch spezielles Hartmetall sehr gut zum Sägen harter Thermoplaste wie z.B. dünne Platten, Hohlkammerplatten aus PC (Polycarbonat), PMMA (Acrylglas-Plexiglas) Siehe hierzu auch Artikel 11.1430 Seite 631

Due to Thin-Cut also ideal for battery machines and for cutting expensive precious wood, veneer, strips because of less waste/battery consumption.

Low number of teeth: Coarse to medium cutting quality in all wooden materials, precious wood and solid wood across and along the grain, panel and boards one-side plastic coated/veneered, paper-based laminate, thicker plastic profiles and plates (Thermoplastics). High feed rate possible

Medium number of teeth: Good cutting quality in all wooden materials, precious wood, solid wood and strips across and along the grain, panel and boards one-side/two side plastic coated/veneered, paper-based laminate, veneer and veneer packages, plastic profiles/plates (Thermoplastics, Duroplastics)

High number of teeth: Very good cutting quality in all wooden materials, precious wood, solid wood and strips preferably across the grain, panel and boards two side plastic coated/veneered, paper-based laminate, veneer and veneer packages, plastic profiles/plates (Thermoplastics, Duroplastics)

Due to special carbide also excellent for cutting hard thermoplastics such as thin panels, hollow section boards Made of PC (Polycarbonate), PMMA (Acrylic-glass/Plexiglass). See here also article 11.1430, page 631



Video







Art.
100
101
102

Massivholz Universal · Wechselzahn · Dünnschnitt
Solid wood universal · Alternate top bevel tooth · Thin-Cut

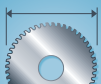
Art. 11.1425

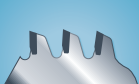
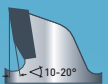

Art.								€
111425.120.010	● 120	1,8/1,2	20	12 WZ	20	-	-	24,10
111425.120.020	● 120	1,8/1,2	20	28 WZ	15	-	-	31,90
111425.120.030	● 120	1,8/1,2	20	44 WZ	10	-	-	41,30
111425.136.010	● 136	1,8/1,2	20/10	14 WZ	20	-	-	25,05
111425.136.020	● 136	1,8/1,2	20/10	30 WZ	15	-	-	32,15
111425.136.030	● 136	1,8/1,2	20/10	48 WZ	10	-	-	45,35
111425.160.010	● 160	1,8/1,2	20/16	16 WZ	20	2-6-32	-	24,80
111425.160.020	● 160	1,8/1,2	20/16	32 WZ	15	2-6-32	-	34,20
111425.160.030	● 160	1,8/1,2	20/16	54 WZ	10	2-6-32	-	46,35
111425.160.040	● 160	1,8/1,2	20/16	68 WZ	10	2-6-32	-	55,80
111425.165.010	● 165	1,8/1,2	20	16 WZ	20	2-6-32	-	25,05
111425.165.020	● 165	1,8/1,2	20	32 WZ	15	2-6-32	-	34,55
111425.165.030	● 165	1,8/1,2	20	54 WZ	10	2-6-32	-	46,80
111425.165.040	● 165	1,8/1,2	20	68 WZ	10	2-6-32	-	55,80
111425.180.010	● 180	1,8/1,2	20/16	18 WZ	20	2-6-32	-	25,45
111425.180.020	● 180	1,8/1,2	20/16	40 WZ	15	2-6-32	-	38,85
111425.180.030	● 180	1,8/1,2	20/16	60 WZ	10	2-6-32	-	53,10
111425.180.040	● 180	1,8/1,2	20/16	76 WZ	10	2-6-32	-	68,25
111425.190.010	● 190	1,8/1,2	30/20	18 WZ	20	2-7-42	-	27,40
111425.190.020	● 190	1,8/1,2	30/20	42 WZ	15	2-7-42	-	42,90
111425.190.030	● 190	1,8/1,2	30/20	60 WZ	10	2-7-42	-	53,70
111425.190.040	● 190	1,8/1,2	30/20	76 WZ	10	2-7-42	-	68,95
111425.200.010	● 200	2,0/1,4	30	18 WZ	20	2-7-42	-	29,00
111425.200.020	● 200	2,0/1,4	30	42 WZ	15	2-7-42	-	43,45
111425.200.030	● 200	2,0/1,4	30	64 WZ	10	2-7-42	-	54,80
111425.200.040	● 200	2,0/1,4	30	80 WZ	10	2-7-42	-	70,85
111425.210.010	● 210	2,0/1,4	30	20 WZ	20	2-7-42	-	30,50
111425.210.020	● 210	2,0/1,4	30	48 WZ	15	2-7-42	-	44,25
111425.210.030	● 210	2,0/1,4	30	64 WZ	10	2-7-42	-	55,65
111425.210.040	● 210	2,0/1,4	30	80 WZ	10	-	-	71,90
111425.216.010	● 216	2,0/1,4	30	20 WZ	20	2-7-42	-	31,50
111425.216.020	● 216	2,0/1,4	30	48 WZ	15	2-7-42	-	45,05
111425.216.030	● 216	2,0/1,4	30	64 WZ	10	2-7-42	-	56,50
111425.216.040	● 216	2,0/1,4	30	80 WZ	10	2-7-42	-	72,70
111425.220.010	● 220	2,0/1,4	30	48 WZ	20	2-7-42	-	45,05
111425.225.010	● 225	2,0/1,4	30	24 WZ	20	2-7-42	-	31,65
111425.225.020	● 225	2,0/1,4	30	48 WZ	15	2-7-42	-	45,90
111425.225.030	● 225	2,0/1,4	30	68 WZ	10	2-7-42	-	61,40
111425.225.040	● 225	2,0/1,4	30	88 WZ	10	2-7-42	-	79,60
111425.230.010	● 230/235 ●	2,0/1,4	30	24 WZ	20	2-7-42	-	32,45
111425.230.020	● 230/235 ●	2,0/1,4	30	48 WZ	15	2-7-42	-	46,60
111425.230.030	● 230/235 ●	2,0/1,4	30	68 WZ	10	2-7-42	-	62,15
111425.230.040	● 230/235 ●	2,0/1,4	30	88 WZ	10	2-7-42	-	80,35
111425.250.010	● 250	2,2/1,6	30	30 WZ	20	UNI	✓	45,90
111425.250.020	● 250	2,2/1,6	30	56 WZ	15	UNI	✓	65,85
111425.250.030	● 250	2,2/1,6	30	80 WZ	10	UNI	✓	73,55
111425.250.040	● 250	2,2/1,6	30	100 WZ	10	UNI	✓	88,15
111425.260.010	● 260	2,2/1,6	30	30 WZ	20	UNI	✓	47,35
111425.260.020	● 260	2,2/1,6	30	56 WZ	15	UNI	✓	67,20
111425.260.030	● 260	2,2/1,6	30	80 WZ	10	UNI	✓	74,55
111425.270.010	● 270	2,2/1,6	30	30 WZ	20	UNI	✓	47,60
111425.270.020	● 270	2,2/1,6	30	56 WZ	15	UNI	✓	67,45
111425.270.030	● 270	2,2/1,6	30	80 WZ	10	UNI	✓	76,50
111425.300.010	● 300	2,2/1,6	30	36 WZ	20	UNI	✓	56,10
111425.300.020	● 300	2,2/1,6	30	60 WZ	15	UNI	✓	74,05
111425.300.030	● 300	2,2/1,6	30	96 WZ	10	UNI	✓	89,15
111425.300.040	● 300	2,2/1,6	30	120 WZ	10	UNI	✓	108,90
111425.350.010	● 350	2,4/1,8	30	42 WZ	20	UNI	✓	68,70
111425.350.020	● 350	2,4/1,8	30	72 WZ	15	UNI	✓	91,05
111425.350.030	● 350	2,4/1,8	30	108 WZ	10	UNI	✓	103,80
111425.350.040	● 350	2,4/1,8	30	140 WZ	10	UNI	✓	150,55
111425.400.010	● 400	2,8/2,2	30	60 WZ	15	UNI	✓	107,25
111425.400.020	● 400	2,8/2,2	30	96 WZ	10	UNI	✓	142,95
111425.400.030	● 400	2,8/2,2	30	120 WZ	10	UNI	✓	166,80
111425.450.010	● 450	3,1/2,5	30	66 WZ	15	UNI	✓	124,55
111425.450.020	● 450	3,1/2,5	30	108 WZ	10	UNI	✓	160,75
111425.450.030	● 450	3,1/2,5	30	130 WZ	10	UNI	✓	186,05
111425.500.010	● 500	3,4/2,8	30	72 WZ	15	UNI+2-10-80	✓	161,05
111425.500.020	● 500	3,4/2,8	30	120 WZ	10	UNI+2-10-80	✓	213,35
111425.500.030	● 500	3,4/2,8	30	144 WZ	10	UNI+2-10-80	✓	240,15

● Gefertigt/Manufactured 232,50 mm · UNI = 2-7-42 + 2-9-46,40 + 2-10-60



Art. 100 101 102

Karnasch® HARTMETALL-BESTÜCKTE KREISSÄGEBLÄTTER CARBIDE TIPPED CIRCULAR SAW BLADES

Art. **11.1450**

GOLD-STAR LINE 

Kapp- und Gehrungskreissägeblätter Wechselzahn/negativ
Chop- and mitre circular saws alternate top bevel tooth/negative

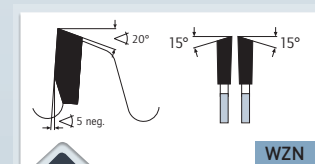



> Wechselzahn Negativ
> Alternate top bevel negative

MASCHINE · MACHINE

Spezialprogramm für Kapp- und Gehrungssägen, Radialkreissägen, Pendelkreissägen, oben liegende Kappkreissägen, Tischkreissägen, Abbundanlagen.

Special selection for chop- and mitre saws, radial saws, pendulum saws, top clipping saws, table saws, trimming saws.

✓ OPTIMAL · OPTIMAL ✓ GUT · GOOD ✓ MÖGLICH · POSSIBLE

✓		Weichholz, Hartholz, Exotenholz, Quer	Soft wood, hard wood, and exotic wood across the grain
✓		Leimholz, Tischler- und Furniersperrholz, Schichtholzplatten	Bonded wood, blockboard and veneer plywood, laminated wood
✓		Spanplatten, Hartfaserplatten, Platten ohne Belag LDF, MDF, HDF	Chipboard, hard fibre board, boards without laminate LDF, MDF, HDF
✓		Kunststoffe, Plexiglas, Duro- und Thermoplaste	Plastics, plexiglass, acrylics, duro- and thermoplastics
✓		Spanplatten, Hartfaserplatten Kunststoff beschichtet/furniert, MDF, HDF	Chipboard, hard fibre board, plastic-coated/veneered, MDF, HDF
✓		Furniere	Veneers
✓		Mineralische/acrylgebundene Massivplatten/Küchenplatten: Corian®, Noblan®, Hi-Macs®, Staron®, Rausolid®, Varicor®	Mineral/acrylic bound solid boards/kitchen worktops: Corian®, Noblan®, Hi-Macs®, Staron®, Rausolid®, Varicor®
✓		HPL-Duroplastische Schichtstoffplatten/Fassadenplatten: Trespa®, Resopal®, Duropal®, Formica®, Kronospan®, Decodur®	HPL High-Pressure-Laminate solid boards/façade panels: Trespa®, Resopal®, Duropal®, Formica®, Kronospan®, Decodur®
✓		Gips-Zement-Steinwollplatten, Eternit, GFK, CFK, HPL, Mineralwerkstoffe	Gypsum/Cement fibre boards, Rockwool, Eternit, GRP, CFK, HPL, Mineral material
✓		Profileleisten	Profiled wood

ANWENDUNG · APPLICATION

Für Querschnitte in Weich- und Hartholz, Holzmischwerkstoffe, Leimholz, Schichtholz, Plattenwerkstoffe furniert oder beschichtet.

Durch spezielles Hartmetall auch hervorragend für Kunststoffe wie kunststoffbeschichtete Profile, dünnes Acrylglas, Duroplast-Profil und Leisten (hohe Zähnezahl wählen).

Ebenfalls für harte Thermoplaste wie PA, PE, PS, POM, ABS.

Durch die negative Zahnform ist das Sägeblatt besser von Hand zu führen und wird nicht in das Schnittgut gezogen.

For cross cuts in soft and hard wood, wooden materials, glued wood, plywood, veneered or coated boards.

Due to special carbide also excellent for plastics such as: plastic laminated profiles, thin acrylic glass, duroplast profiles and strips (high number of teeth recommended).

Also for hard thermoplastics such as PA, PE, PS, POM, ABS.

Due to the negative tooth shape, that saw blade can be guided easier by hand and is not pulled into the material to be cut.



Video



1



2



3



4



5



6



7



8



9



10







Art.
100
101
102

Kapp- und Gehrungskreissägeblätter Wechselzahn/negativ
Chop- and mitre circular saws alternate top bevel tooth/negative

Art. **11.1450**

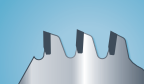
GOLD-STAR LINE 

Art.							€
111450.210.010	• 210	2,8/1,8	30	24 WZN	2-7-42	-	26,95
111450.210.020	• 210	2,8/1,8	30	48 WZN	2-7-42	-	41,15
111450.216.010	• 216	2,8/1,8	30	24 WZN	2-7-42	-	29,80
111450.216.020	• 216	2,8/1,8	30	48 WZN	2-7-42	-	41,15
111450.216.030	• 216	2,8/1,8	30	60 WZN	2-7-42	-	45,70
111450.216.040	• 216	2,8/1,8	30	80 WZN	2-7-42	-	57,75
111450.250.010	• 250	3,2/2,2	30	24 WZN	UNI	✓	34,65
111450.250.020	• 250	3,2/2,2	30	40 WZN	UNI	✓	46,70
111450.250.030	• 250	3,2/2,2	30	60 WZN	UNI	✓	58,35
111450.250.040	• 250	3,2/2,2	30	80 WZN	UNI	✓	67,20
111450.260.010	• 260	2,5/1,8	30	48 WZN	UNI	✓	56,40
111450.260.020	• 260	2,5/1,8	30	60 WZN	UNI	✓	71,40
111450.260.030	• 260	2,5/1,8	30	80 WZN	UNI	✓	76,95
111450.300.010	• 300	3,2/2,2	30	72 WZN	UNI	✓	70,20
111450.305.010	• 305	2,6/1,8	30	32 WZN	UNI	✓	54,55
111450.305.020	• 305	2,6/1,8	30	48 WZN	UNI	✓	57,40
111450.305.030	• 305	2,6/1,8	30	60 WZN	UNI	✓	57,40
111450.305.040	• 305	2,6/1,8	30	72 WZN	UNI	✓	71,95
111450.305.050	• 305	2,6/1,8	30	96 WZN	UNI	✓	85,50
111450.305.060	▲ 305	2,6/1,8	30	100 WZN	UNI	✓	83,20
111450.350.010	• 350	4,4/2,8	30	42 WZN	UNI	✓	94,05
111450.400.010	• 400	4,4/2,8	30	48 WZN	UNI	✓	107,20
111450.420.010	• 420	4,2/2,8	40/30	48 WZN	2-10-60+2-11-63+2-12-64	✓	115,25
111450.420.020	• 420	3,5/2,5	40/30	84 WZN	2-10-60+2-11-63+2-12-64	✓	156,30
111450.450.010	• 450	4,4/2,8	30	54 WZN	UNI	✓	122,95
111450.500.010	• 500	4,4/2,8	30	60 WZN	UNI	✓	143,90
111450.550.010	• 550	4,8/3,4	30	64 WZN	UNI	✓	182,55
111450.600.010	• 600	5,4/4,0	30	72 WZN	UNI	✓	228,35

UNI = 2-7-42 + 2-9-46,40 + 2-10-60

1



2



3



4



5



6



7



8



9



10



Art.
100
101
102

Karnasch® HARTMETALL-BESTÜCKTE KREISSÄGEBLÄTTER CARBIDE TIPPED CIRCULAR SAW BLADES

Art. **11.1400**

Handkreissägen + Lamello
Portable circular saws + Lamello

GOLD-STAR LINE 

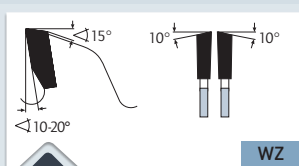

> Wechselzahn
> Alternate top bevel

MASCHINE · MACHINE







Für Handkreissägen, Tauchsägen, Tischkreissägen, Kappkreissägen.

For portable circular saws, table saws, bench saws, cross-cut saws.

Lamello-Nebenlöcher **NL 2 / 4,5 / 30 + NL 3 / 5 / 36** gesenkt, mit Bohrung 22,00 mm

Pin holes Lamello **NL 2 / 4,5 / 30 + NL 3 / 5 / 36** countersunk, with bore 22,00 mm

✓ OPTIMAL · OPTIMAL ✓ GUT · GOOD ✓ MÖGLICH · POSSIBLE

✓		Weichholz, Hartholz, Exotenholz, Quer	Soft wood, hard wood, and exotic wood across the grain
✓		Weichholz, Hartholz, Exotenholz Längs	Soft wood, hard wood, and exotic wood along the grain
✓		Leimholz, Tischler- und Furniersperrholz, Schichtholzplatten	Bonded wood, blockboard and veneer plywood, laminated wood
✓		Spanplatten, Hartfaserplatten, Platten ohne Belag LDF, MDF, HDF	Chipboard, hard fibre board, boards without laminate LDF, MDF, HDF
✓		Kunststoffe, Plexiglas, Duro- und Thermoplaste	Plastics, plexiglass, acrylics, duro- and thermoplastics
✓		Spanplatten, Hartfaserplatten Kunststoff beschichtet/furniert, MDF, HDF	Chipboard, hard fibre board, plastic-coated/veneered, MDF, HDF
✓		Furniere	Veneers
✓		Profileleisten	Profiled wood
✓		Mineralische/acrylgebundene Massivplatten/Küchenplatten: Corian®, Noblan®, Hi-Macs®, Staron®, Rausolid®, Varicor®	Mineral/acrylic bound solid boards/kitchen worktops: Corian®, Noblan®, Hi-Macs®, Staron®, Rausolid®, Varicor®
✓		HPL-Duroplastische Schichtstoffplatten/Fassadenplatten: Trespa®, Resopal®, Duropal®, Formica®, Kronospan®, Decodur®	HPL High-Pressure-Laminate solid boards/façade panels: Trespa®, Resopal®, Duropal®, Formica®, Kronospan®, Decodur®
✓		Gips-Zement-Steinwollplatten, Eternit, GFK, CFK, HPL, Mineralwerkstoffe	Gypsum/Cement fibre boards, Rockwool, Eternit, GRP, CFK, HPL, Mineral material

ANWENDUNG · APPLICATION

Niedere Zähnezahl: Holz, Leimholz, Spanplatten roh.

Mittlere Zähnezahl für: Holz, Leimholz, Tischplatten, Spanplatten roh, Spanplatten einseitig beschichtet / furniert.

Hohe Zähnezahl für: Spanplatten roh, Spanplatten 1- und 2-seitig beschichtet / furniert.

Kunststoffe, Thermoplaste.

Low number of teeth: Wood, laminated wood, coarse chipboard.

Average number of teeth for: Wood, laminated wood, tabletops, coarse chipboard, chipboard with coating / veneer on one side.

High number of teeth for: Coarse chipboard, chipboard that is coated/veneered on 1 and 2 sides.

Plastics, thermoplastics.

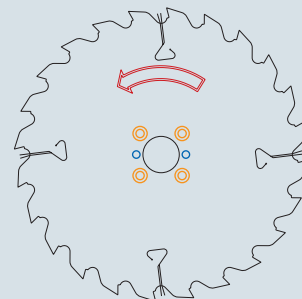
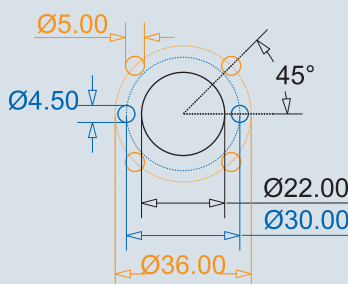

Video

1

2

3

4

5

6

7

8

9

10

Art.
100
101
102

Handkreissägen + Lamello
Portable circular saws + Lamello

Art. 11.1400



Art.								€
111400.100.010	● 100	2,6/1,6	12	30 WZ	10°	-	-	24,05
111400.100.020	● 100	2,6/1,6	22/20	30 WZ	10°	Lamello	-	34,90
111400.100.030	● 100	3,97/2,8	22	6 WZ	20°	Lamello	-	25,20
111400.100.040	● 100	3,97/2,8	22	12 WZ	20°	Lamello	-	32,65
111400.105.010	● 105	2,6/1,6	22/20	30 WZ	10°	-	-	25,75
111400.120.010	● 120	2,4/1,4	22	24 WZ	15°	Lamello	-	31,10
-	● 120	1,8/1,2	20	12/28/44 WZ	-	Siehe/See Art. 11.1425 Seite/Page 663	-	-
111400.125.010	● 125	2,6/1,6	20/12,7	24 WZ	15°	-	-	21,75
111400.125.020	● 125	2,6/1,6	20/12,7	36 WZ	10°	-	-	28,50
111400.130.010	● 130	2,6/1,6	20/16	24 WZ	15°	-	-	21,75
111400.130.020	● 130	2,6/1,6	20/16	36 WZ	10°	-	-	28,50
-	● 136	1,8/1,2	20/10	14/30/48	-	Siehe/See Art. 11.1425 Seite/Page 663	-	-
111400.140.010	● 140	2,6/1,6	20	12 WZ	20°	-	-	16,30
111400.140.020	● 140	2,6/1,6	20	20 WZ	15°	-	-	20,00
111400.140.030	● 140	2,6/1,6	20	36 WZ	10°	-	-	31,20
111400.150.010	● 150	2,6/1,6	20/16	12 WZ	20°	2-6-32	-	17,85
111400.150.020	● 150	2,6/1,6	20/16	24 WZ	15°	2-6-32	-	21,75
111400.150.030	● 150	2,6/1,6	20/16	36 WZ	10°	2-6-32	-	22,65
111400.150.040	● 150	2,6/1,6	20/16	48 WZ	10°	2-6-32	-	37,10
111400.150.045	● 150	2,6/1,6	22	24 WZ	15°	Lamello	-	30,45
111400.150.050	▲ 150	2,6/1,6	30	12 WZ	20°	-	-	16,65
111400.150.060	● 150	2,6/1,6	30	24 WZ	15°	-	-	21,30
111400.150.070	● 150	2,6/1,6	30	36 WZ	10°	-	-	21,30
111400.150.080	● 150	2,6/1,6	30	48 WZ	10°	-	-	37,10
111400.160.010	● 160	2,6/1,6	20/16	12 WZ	20°	2-6-32	-	18,80
111400.160.020	● 160	2,6/1,6	20/16	24 WZ	15°	2-6-32	-	23,50
111400.160.030	● 160	2,6/1,6	20/16	36 WZ	10°	2-6-32	-	29,85
111400.160.040	● 160	2,6/1,6	20/16	48 WZ	10°	2-6-32	-	37,10
111400.160.050	● 160	2,6/1,6	30	12 WZ	20°	2-7-42	-	17,40
111400.160.060	● 160	2,6/1,6	30	24 WZ	15°	2-7-42	-	22,05
111400.160.070	● 160	2,6/1,6	30	36 WZ	10°	2-7-42	-	29,50
111400.160.080	● 160	2,6/1,6	30	48 WZ	10°	2-7-42	-	37,00
111400.165.010	● 165	2,6/1,6	20	24 WZ	15°	2-6-32	-	23,65
111400.165.020	● 165	2,6/1,6	20	36 WZ	10°	2-6-32	-	29,50
111400.165.030	● 165	2,6/1,6	20	48 WZ	10°	2-6-32	-	37,00
111400.170.010	● 170	2,6/1,6	20/16	24 WZ	15°	-	-	24,65
111400.170.020	● 170	2,6/1,6	30	24 WZ	15°	2-7-42	-	22,65
111400.170.030	● 170	2,6/1,6	30	36 WZ	15°	2-7-42	-	30,45
111400.170.040	● 170	2,6/1,6	30	48 WZ	10°	2-7-42	-	38,25
111400.180.010	● 180	2,8/1,8	20/16	14 WZ	20°	2-6-32	-	23,25
111400.180.020	● 180	2,8/1,8	20/16	24 WZ	20°	2-6-32	-	24,65
111400.180.030	● 180	2,8/1,8	20/16	40 WZ	15°	2-6-32	-	35,65
111400.180.040	● 180	2,8/1,8	20/16	56 WZ	10°	2-6-32	-	45,50
111400.180.043	▲ 180	2,5/1,4	22	12 WZ	20°	Lamello	-	36,30
111400.180.046	● 180	2,8/1,8	22	24 WZ	20°	Lamello	-	33,05
111400.180.050	● 180	2,8/1,8	30	14 WZ	20°	2-7-42	-	22,55
111400.180.060	● 180	2,8/1,8	30	24 WZ	20°	2-7-42	-	24,05
111400.180.070	● 180	2,8/1,8	30	40 WZ	15°	2-7-42	-	35,65
111400.180.080	● 180	2,8/1,8	30	56 WZ	10°	2-7-42	-	44,45
111400.185.010	● 185	2,8/1,8	20/16	14 WZ	20°	2-6-32	-	23,50
111400.185.020	● 185	2,8/1,8	20/16	24 WZ	20°	2-6-32	-	24,95
111400.185.030	● 185	2,8/1,8	20/16	40 WZ	15°	2-6-32	-	36,30
111400.185.040	● 185	2,8/1,8	20/16	56 WZ	10°	2-6-32	-	44,55
111400.190.010	● 190	2,8/1,8	20/16	16 WZ	20°	2-6-32	-	23,50
111400.190.020	● 190	2,8/1,8	20/16	30 WZ	15°	2-6-32	-	28,75
111400.190.030	● 190	2,8/1,8	20/16	48 WZ	10°	2-6-32	-	40,20
111400.190.040	● 190	2,8/1,8	20/16	60 WZ	10°	2-6-32	-	46,20
111400.190.050	● 190	2,8/1,8	30	16 WZ	20°	2-7-42	-	20,60
111400.190.060	● 190	2,8/1,8	30	30 WZ	15°	2-7-42	-	26,60
111400.190.070	● 190	2,8/1,8	30	48 WZ	10°	2-7-42	-	39,50
111400.190.080	● 190	2,8/1,8	30	60 WZ	10°	2-7-42	-	44,80
111400.200.003	▲ 200	2,4/1,6	22	12 WZ	20°	Lamello	-	27,30
111400.200.007	▲ 200	2,4/1,6	22	24 WZ	20°	Lamello	-	32,75
111400.200.010	● 200	2,8/1,8	30	18 WZ	20°	2-7-42	-	22,65
111400.200.020	● 200	2,8/1,8	30	30 WZ	15°	2-7-42	-	28,60
111400.200.030	● 200	2,8/1,8	30	48 WZ	10°	2-7-42	-	40,00
111400.200.040	● 200	2,8/1,8	30	64 WZ	10°	2-7-42	-	47,60

UNI = 2-7-42 + 2-9-46,40 + 2-10-60

Fortsetzung nächste Seite · Continue to next page











Art.
100
101
102

Karnasch® HARTMETALL-BESTÜCKTE KREISSÄGEBLÄTTER CARBIDE TIPPED CIRCULAR SAW BLADES

Art. **11.1400**

Handkreissägen
Portable circular saws

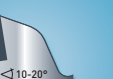
GOLD-STAR LINE 

Art.										€
111400.210.010	• 210	2,8/1,8	30	18 WZ	20°		2-7-42	-		21,75
-	• 210	2,0/1,4	30	20/48/64 WZ	-		Siehe/See Art. 11.1425 Seite/Page 663			
111400.210.020	• 210	2,8/1,8	30	30 WZ	15°		2-7-42	-		29,30
111400.210.030	• 210	2,8/1,8	30	48 WZ	10°		2-7-42	-		40,60
111400.210.040	• 210	2,8/1,8	30	64 WZ	10°		2-7-42	-		48,15
-	• 216	Siehe Tabelle nach Ø und Anwendung (Index)/See table according Ø and application (index)								
111400.220.010	• 220	2,8/1,8	30	20 WZ	20°		2-7-42	-		25,20
111400.220.020	• 220	2,8/1,8	30	36 WZ	15°		2-7-42	-		33,65
111400.220.030	• 220	2,8/1,8	30	48 WZ	15°		2-7-42	-		41,20
-	• 220	2,0/1,4	30	48 WZ	-		Siehe/See Art. 11.1425 Seite/Page 663			
111400.225.040	• 220	2,8/1,8	30	64 WZ	10°		2-7-42	-		49,00
111400.225.010	• 225	2,8/1,8	30	24 WZ	20°		2-7-42	-		26,30
-	• 225	2,0/1,4	30	24/48/68 WZ	-		Siehe/See Art. 11.1425 Seite/Page 663			
111400.225.020	• 225	2,8/1,8	30	36 WZ	15°		2-7-42	-		33,80
111400.225.030	• 225	2,8/1,8	30	48 WZ	15°		2-7-42	-		41,30
111400.225.040	• 225	2,8/1,8	30	64 WZ	10°		2-7-42	-		49,25
111400.230.010	• 230/235	2,8/1,8	30	24 WZ	20°		2-7-42	-		26,70
-	• 230/235	2,0/1,4	30	24/48/68 WZ	-		Siehe/See Art. 11.1425 Seite/Page 663			
111400.230.020	• 230/235	2,8/1,8	30	36 WZ	15°		2-7-42	-		33,80
111400.230.030	• 230/235	2,8/1,8	30	48 WZ	15°		2-7-42	-		41,30
111400.230.040	• 230/235	2,8/1,8	30	64 WZ	10°		2-7-42	-		50,40
111400.240.010	• 240	3,0/2,0	30	24 WZ	20°		2-7-42	-		28,10
111400.240.020	• 240	3,0/2,0	30	36 WZ	15°		2-7-42	-		35,00
111400.240.030	• 240	3,0/2,0	30	48 WZ	15°		2-7-42	-		44,40
-	• 250	Siehe Tabelle nach Ø und Anwendung (Index)/See table according Ø and application (index)								
111400.255.010	• 255	3,0/2,0	30	36 WZ	15°		UNI	-		36,75
111400.255.020	• 255	3,0/2,0	30	48 WZ	15°		UNI	-		44,60
111400.255.030	• 255	3,0/2,0	30	64 WZ	10°		UNI	-		55,00
111400.255.040	• 255	3,0/2,0	30	80 WZ	10°		UNI	-		63,00
111400.260.010	• 260	3,2/2,2	30	24 WZ	20°		UNI	-		35,65
-	• 260	2,2/1,6	30	30/56/80 WZ	-		Siehe/See Art. 11.1425 Seite/Page 663			
111400.260.020	• 260	3,2/2,2	30	48 WZ	15°		UNI	-		52,20
111400.260.030	• 260	3,2/2,2	30	64 WZ	10°		UNI	-		64,80
111400.270.010	• 270	3,2/2,2	30	24 WZ	20°		UNI	-		40,15
-	• 270	2,2/1,6	30	30/56/80 WZ	-		Siehe/See Art. 11.1425 Seite/Page 663			
111400.270.020	• 270	3,2/2,2	30	48 WZ	15°		UNI	-		51,20
111400.270.030	• 270	3,2/2,2	30	80 WZ	10°		UNI	-		76,90
111400.280.010	• 280	3,2/2,2	30	48 WZ	15°		UNI	-		52,20
111400.280.020	• 280	3,2/2,2	30	64 WZ	10°		UNI	-		65,05
-	• 300	Siehe Tabelle nach Ø und Anwendung (Index)/See table according Ø and application (index)								
111400.330.010	• 330	3,2/2,2	30	24 WZ	20°		UNI	-		41,55
111400.330.020	• 330	3,2/2,2	30	40 WZ	20°		UNI	-		51,70
111400.330.030	• 330	3,2/2,2	30	60 WZ	15°		UNI	-		66,30
111400.335.010	• 335	3,2/2,2	30	36 WZ	20°		UNI	-		50,10
111400.335.020	• 335	3,2/2,2	30	60 WZ	15°		UNI	-		66,75
-	• 350	Siehe Tabelle nach Ø und Anwendung (Index)/See table according Ø and application (index)								
111400.355.010	• 355	3,2/2,2	30	30 WZ	20°		UNI	-		50,95
111400.355.020	• 355	3,2/2,2	30	60 WZ	15°		UNI	-		68,15

• Gefertigt/Manufactured 232,50 mm · UNI = 2-7-42 + 2-9-46,40 + 2-10-60

- 1 
- 2 
- 3 
- 4 
- 5 
- 6 
- 7 
- 8 
- 9 
- 10 

Ritzer 2-teilig
Split scoring saw blades (2-part)

Art. 11.1480

GOLD-STAR LINE



✓ OPTIMAL · OPTIMAL ✓ GUT · GOOD ✓ MÖGLICH · POSSIBLE

✓		Spanplatten, Hartfaserplatten Kunststoff beschichtet/furniert, MDF, HDF	Chipboard, hard fibre board, plastic-coated/veneered, MDF, HDF
---	--	---	--

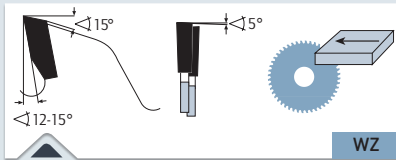

> Wechselzahn
> Alternate top bevel

MASCHINE · MACHINE

Für Formatsägen und Plattenaufteilsägen mit Vorritzaggregat.

For panel sizing machines with scoring aggregate.

ANWENDUNG · APPLICATION

Zum Vorritzen von Kunststoffbeschichteten oder furnierten Plattenmaterialien

For scoring laminated or veneered panel materials

Art.	Maschinenhersteller Machine manufacturers							€
111480.080.010	Felder, Striebig	• 80	2,8-3,6	2,2	20	2x10 WZ	-	91,80
111480.100.010	Schelling KS, MartinT70, Panhans 684+685A	• 100	2,8-3,6	2,2	20	2x12 WZ	-	81,55
111480.100.020	Altendorf, Panhans, Striebig	• 100	2,8-3,6	2,2	22	2x12 WZ	-	81,55
111480.120.010	Holz-Her, SCM S1, MAKA	• 120	2,8-3,6	2,2	20	2x12 WZ	-	83,35
111480.120.020	Altendorf T70, Martin T72 A	• 120	2,8-3,6	2,2	22	2x12 WZ	-	83,35
111480.120.030	Martin-System*	• 120	2,8-3,8	2,2	22	2x12 WZ	4-4,6-39/4-4,6-55	103,35
111480.120.040	Altendorf, Rapido, Leuco-System*	• 120	2,8-3,8	2,2	50	2x12 WZ	4-6,4-62	101,50
111480.125.010	Panhans, Paoloni	• 125	2,8-3,6	2,2	20	2x12 WZ	-	83,35
111480.125.020	Altendorf, Martin	• 125	2,8-3,6	2,2	22	2x12 WZ	-	83,35

- Die Ritzsägen kommen mit einem Satz Distanzscheiben: 1 x 0,1 mm · 1 x 0,2 mm · 2 x 0,3 mm
The scoring blades comes with a set of spacers/intermediate discs: 1 x 0,1mm · 1 x 0,2mm · 2 x 0,3mm
- Martin-System* sowie Altendorf, Rapido, Leuco-System* kommen ohne Distanzscheiben da Schnittbreitenverstellung an der Maschine erfolgt.
Martin-System* and Altendorf, Rapido, Leuco-System* comes without spacers/intermediate discs because the width is adjusted on the machine.
- Weitere Ritzer siehe Seite 615
More scoring blades see page 615



Video

669



Art.
100
101
102

Art. **11.1150**
HM/T.C.T.

Glasleisten Kreissägen
Glazing bead (glass ledge) circular saws

Art. **11.1170**
HSS-LINE

GOLD-STAR LINE ★



GOLD-STAR LINE ★



- 1
- 2
- 3
- 4
- 5
- 6
- 7
- 8
- 9
- 10

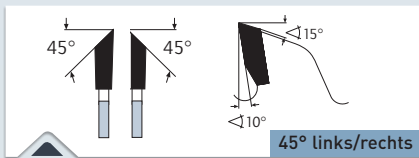

45° links/rechts

- > 45° links / rechts = Einseitig spitz 45° links oder rechts geschliffen
Für Kunststoffprofile, Holzwerkstoffe
- > 45° left / right = 45° acute on one side, left or right cut
For plastic profile, wooden material

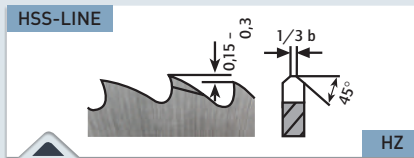

HZ

- > HZ = Bogenzahn mit Vor- und Nachschneider
Für Kunststoffprofile, Aluminiumprofile
- > HZ = Precutter tooth with bevels sides and finishing tooth without bevels
For plastic profile, aluminium profile

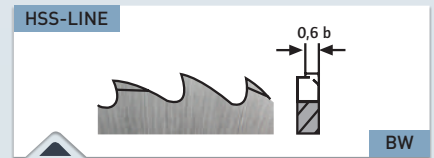

BW

- > BW = Bogenzahn mit wechselseitiger Abkantung
Für Kunststoffprofile, Aluminiumprofile
- > BW = Tooth with alternate bevels
For plastic profile, aluminium profile

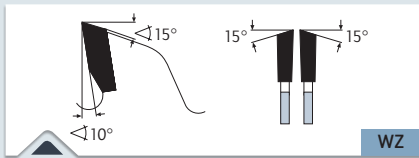

WZ

- > WZ = Wechselzahn
Für Kunststoffprofile, Holzwerkstoffe
- > WZ = Alternate top bevel
For plastic profile, wooden material

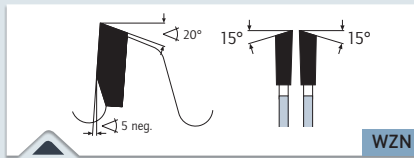

WZN

- > WZN = Wechselzahn negativer Spanwinkel
Für Kunststoffprofile, Holzwerkstoffe
- > WZN = Alternate top bevel, negative cutting angle
For plastic profile, wooden material

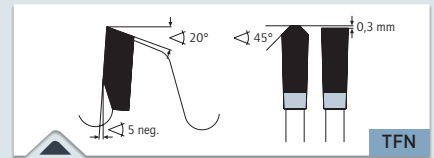

TFN

- > TFN = Trapez / Flachzahn negativer Spanwinkel
Für Kunststoffprofile, Aluminiumprofile
- > TFN = Triple-chip flat tooth, negative cutting angle
For plastic profile, aluminium profile

MASCHINE · MACHINE

Für Spezialmaschinen wie Glasleistensägen von HAFFNER, ROTOX, WEGOMA, STRIFFLER u.ä.

For special machines, such as glazing bead saws from HAFFNER, ROTOX, WEGOMA, STRIFFLER, etc.

ANWENDUNG · APPLICATION

Sägen für den Fensterbau z.B. Auftrennen von Glasleisten und als Kappfase-Satz. Material: Kunststoffprofil, Aluminiumprofil, Holzwerkstoffe.

Saw blades for window fitting, e.g. cutting glazing beads. Removing glass ledges or as trimmin set. Material: plastic profile, aluminium profile, wooden material.



Video

Art.
100
101
102

Glasleisten Kreissägen
Glazing bead (glass ledge) circular saws

Art. **11.1150**
HM/T.C.T.



GOLD-STAR LINE

Hartmetall-bestückt

Carbide tipped



Art.	Maschinenhersteller Machine manufacturers						€
111150.092.010	Rotox	▲ 92	3,0/2,5	30	24 / 45° links	-	52,20
111150.092.020	Rotox	▲ 92	3,0/2,5	30	24 / 45° rechts	-	52,20
111150.095.010	Haffner, Rapid	● 95	2,1/1,6	20	20 / 45° links	-	40,30
111150.095.020	Haffner, Rapid	● 95	2,1/1,6	20	20 / 45° rechts	-	40,30
111150.098.010	Elu	● 98	3,0/2,0	32	36 / 45° links	-	64,65
111150.098.020	Elu	● 98	3,0/2,0	32	36 / 45° rechts	-	64,65
111150.103.010	Wegoma	● 103	2,1/1,6	32	24 / 45° links	-	44,80
111150.103.020	Wegoma	● 103	2,1/1,6	32	24 / 45° rechts	-	44,80
111150.138.010	Rotox	▲ 138	2,5/2,0	14	24 FL	-	48,15
111150.138.020	Rotox	▲ 138	2,5/2,0	20	24 FL	-	48,15
111150.175.010	Haffner	● 175	2,1/1,6	20	68 WZ	-	80,05
111150.200.010	Rapid, Striffler	● 200	2,1/1,6	20	80 WZ	-	77,20
111150.200.020	Rapid, Striffler	● 200	2,1/1,6	20	80 WZN	-	77,20
111150.200.030	Rapid, Striffler	● 200	2,2/1,8	20	100 TFN	-	103,50
111150.200.040	Wegoma	● 200	2,1/1,6	32	80 WZ	-	77,20
111150.200.050	Rotox	● 200	2,2/1,8	30	100 TFN	-	103,50
111150.200.060	Wegoma	● 200	2,2/1,8	32	100 TFN	-	103,50
111150.200.070	Wegoma, Rotox	● 200	2,2/1,8	32/30	100 WZN	-	104,95
111150.250.010	Haffner	● 250	2,2/1,8	20	120 WZN	-	124,80
	BMJ, Rapid	● 250	2,2/1,8	30	100 TFN	Siehe/See Art. 11.1120, Seite/Page 571	
	BMJ, Rapid	● 250	2,2/1,8	32/30	120 TFN	Siehe/See Art. 11.1120, Seite/Page 571	
		● 300	2,4/1,8	30	120 TFN	Siehe/See Art. 11.1120, Seite/Page 571	
		● 350	2,7/2,0	30	120 TFN	Siehe/See Art. 11.1120, Seite/Page 571	
		● 400	3,0/2,4	30	130 TFN	Siehe/See Art. 11.1120, Seite/Page 571	

Weitere Alu-Negativ TFN Verzahnung siehe Artikel 11.1100 Seite 569 und 11.1120 Seite 571 · Other aluminium negativ TFN teeth, see article 11.1100 page 569 and 11.1120 page 571

		Kunststoffe, Plexiglas, Duro- und Thermoplaste	Plastics, plexiglass, acrylics, duro- and thermoplastics
		Ne-Metall wie Alu, Messing, Kupfer	Non ferrous materials like alu, copper, brass
		Weichholz, Hartholz, Exotenholz, Quer	Soft wood, hard wood, and exotic wood across the grain

OPTIMAL · OPTIMAL

GUT · GOOD

MÖGLICH · POSSIBLE

Vollstahl HSS

Solid steel HSS

Art. **11.1170**
HSS-LINE



GOLD-STAR LINE



Art.	Maschinenhersteller Machine manufacturers						€
111170.103.010	Wegoma	● 103	2,0	32	60 / 45° links	-	48,35
111170.103.020	Wegoma	● 103	2,0	32	60 / 45° rechts	-	48,35
111170.200.010	Wegoma	● 200	2,0	32	180 HZ	2-8-45	38,90
	Wegoma, STB	● 250	2,0	32	200 BW	Siehe/See Art. 51000.250.170, Seite/Page 686	

		Kunststoffe, Plexiglas, Duro- und Thermoplaste	Plastics, plexiglass, acrylics, duro- and thermoplastics
		Ne-Metall wie Alu, Messing, Kupfer	Non ferrous materials like alu, copper, brass

OPTIMAL · OPTIMAL

GUT · GOOD

MÖGLICH · POSSIBLE



Video

671

1



2



3



4



5



6



7



8



9



10



Art.
100
101
102

Karnasch® HARTMETALL-BESTÜCKTE KREISSÄGEBLÄTTER CARBIDE TIPPED CIRCULAR SAW BLADES

Art. **11.1340**

GOLD-STAR LINE 

Kreissägen für Straßenrand Freischneider / Böschungsmäher von Mulag, Spearhead, Power usw.
Circular saws for roadside maintenance hedging and sliding machines from Mulag, Spearhead, Power etc.



- 1 
- 2 
- 3 
- 4 
- 5 
- 6 
- 7 
- 8 
- 9 
- 10 

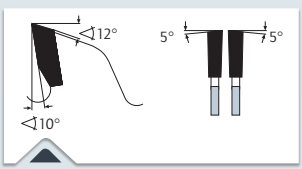



> Wechselzahn
> Alternate top bevel

MASCHINE · MACHINE

Passend für MULAG, Spearhead, Power und weitere Straßenrand Freischneider/Böschungsmäher

Suitable for MULAG, Spearhead, Power and other roadside maintenance hedging and siding machines





✓ OPTIMAL · OPTIMAL ✓ GUT · GOOD ✓ MÖGLICH · POSSIBLE

✓ 	Weichholz, Hartholz, Exotenholz, Quer	Soft wood, hard wood, and exotic wood across the grain
✓ 	Weichholz, Hartholz, Exotenholz Längs	Soft wood, hard wood, and exotic wood along the grain

ANWENDUNG · APPLICATION

Kürzen von Ästen und Gestrüpp am Straßenrand.

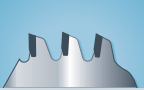
For cutting branches, twigs and undergrowth on the roadside.

Art.						€
111340.390.010	• 390	3,5/2,5	25	60 WZ	6-8,0-64	109,65
111340.500.010	• 500	4,0/3,0	30	60 WZ	6-8,5-80	141,20
111340.500.020	• 500	4,0/3,0	30	72 WZ	6-8,5-80	153,35
111340.590.010	• 590	4,5/3,6	30	78 WZ	6-8,5-80	219,60
111340.600.010	• 600	4,0/3,0	45	60 WZ	2-18-120	219,25

Art. 100
101
102



Kreissägen für Vogesenblitz Trommelsäge SAT 4-700
Circular saw for Vogesenblitz cylinder/circular barrel saw

Art. 11.1345

GOLD-STAR LINE 

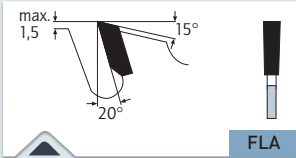



- > Flachzahn mit Abweiser
- > Flat tooth with chip limiter

MASCHINE · MACHINE

Passend für Vogesenblitz Trommelsäge SAT 4-700

Suitable for Vogesenblitz cylinder/circular barrel saw SAT 4-700

- ✓ OPTIMAL · OPTIMAL
- ✓ GUT · GOOD
- ✓ MÖGLICH · POSSIBLE

✓		Weichholz, Hartholz, Exotenholz, Quer	Soft wood, hard wood, and exotic wood across the grain
✓		Weichholz, Hartholz, Exotenholz Längs	Soft wood, hard wood, and exotic wood along the grain

ANWENDUNG · APPLICATION

Zum Trennen von Holzscheite mit einer Länge bis 1200 mm und Durchmesser bis 270 mm.

For sawing logs with a length up to 1200 mm and diameters up to 270 mm.

Art.						€
111345.700.010	700	6,0/4,5	30	42 FLA	-	374,40



Video 

673

1



2



3



4



5



6



7



8



9



10



Art.
100
101
102

Karnasch® ORBITALE ROHRKREISSÄGEBLÄTTER HSS-Co5 COBALT 5 % ORBITAL PIPE CUTTING CIRCULAR SAW BLADES HSS-Co5 COBALT 5 %

Orbitale Rohrkreissägeblätter für: Georg Fischer (GF), Axxair, Protem, Orbitalum
Orbital pipe cutting circular saw blades for: Georg Fischer (GF), Axxair, Protem, Orbitalum

Art. **5.3980**



HSS-Co5 Cobalt: Zum Sägen von Rohren aus Edelstahl, Stahl, Ne-Metalle

HSS-Co5 Cobalt: For cutting pipes made of stainless steel, steel, non ferrous metals

Art.	Passend für Maschine Suitable for machine					Für Wandstärken For pipe thickness	€
53980.063.010	GF, Axxair, Protem, Orbitalum	● 63	1,6	16	64 BW	1-3 mm	18,75
53980.063.020	GF, Axxair, Protem, Orbitalum	● 63	1,6	16	100 BW	0,6-1,5 mm	18,75
53980.068.010	GF, Axxair, Protem, Orbitalum	● 68	1,6	16	44 BW	2-7 mm	19,50
53980.068.020	GF, Axxair, Protem, Orbitalum	● 68	1,6	16	72 BW	1-3 mm	19,50
53980.080.010	GF, Axxair, Orbitalum	● 80	2,0	16	34 BW	5-12 mm	25,50
53980.080.020	GF, Axxair, Orbitalum	● 80	2,0	16	54 BW	2-7 mm	25,50
53980.080.030	GF, Axxair, Orbitalum	● 80	2,0	16	80 BW	1-3 mm	25,50

Für höchste Standzeiten siehe neue Artikel 5.3965 nächste Seite · For maximum tool life see new article 5.3965 next page.

Art. **5.3990**



HSS-Co5 Cobalt + **Kx beschichtet**: Zum Sägen von Rohren aus Edelstahl, Stahl, Ne-Metalle.

Durch **Kx-Beschichtung** werden höchste Standzeiten erreicht (auch bei nicht optimaler Kühlung)

HSS-Co5 Cobalt + **Kx coating**: For cutting pipes made of stainless steel, steel, non ferrous metals.
By **Kx coating** excellent tool life (even at sub-optimal cooling)

Art.	Passend für Maschine Suitable for machine					Für Wandstärken For pipe thickness	€
53990.063.010	GF, Axxair, Protem, Orbitalum	● 63	1,6	16	64 BW	1-3 mm	24,45
53990.063.020	GF, Axxair, Protem, Orbitalum	● 63	1,6	16	100 BW	0,6-1,5 mm	24,45
53990.068.010	GF, Axxair, Protem, Orbitalum	● 68	1,6	16	44 BW	2-7 mm	25,65
53990.068.020	GF, Axxair, Protem, Orbitalum	● 68	1,6	16	72 BW	1-3 mm	25,65
53990.080.010	GF, Axxair, Orbitalum	● 80	2,0	16	34 BW	5-12 mm	31,95
53990.080.020	GF, Axxair, Orbitalum	● 80	2,0	16	54 BW	2-7 mm	31,95
53990.080.030	GF, Axxair, Orbitalum	● 80	2,0	16	80 BW	1-3 mm	31,95

Für höchste Standzeiten siehe neue Artikel 5.3965 nächste Seite · For maximum tool life see new article 5.3965 next page.

Art. **5.4000**



HSS-DMo5: Zum Sägen von Rohren aus Stahl, Ne-Metalle

HSS-DMo5: For cutting pipes made of steel, non ferrous metals

Art.	Passend für Maschine Suitable for machine					Für Wandstärken For pipe thickness	€
54000.063.010	GF, Orbitalum	▲ 63	1,6	16	44 BW	2-7 mm	14,25
54000.063.020	GF, Orbitalum	▲ 63	1,6	16	80 BW	1-3 mm	14,25
54000.068.010	GF, Orbitalum	▲ 68	1,6	16	44 BW	2-7 mm	15,40

Auslaufartikel! Ersatzartikel siehe oben Artikel 5.3980
Discontinued! Alternative article see above article 5.3980

Art. **5.4010**



HSS-Co5 Cobalt: Zum Sägen von Rohren aus Edelstahl, Stahl, Ne-Metalle

HSS-Co5 Cobalt: For cutting pipes made of stainless steel, steel, non ferrous metals

Art.	Passend für Maschine Suitable for machine					Für Wandstärken For pipe thickness	€
54010.063.010	GF, Orbitalum	▲ 63	1,6	16	44 BW	2-7 mm	16,75
54010.063.020	GF, Orbitalum	▲ 63	1,6	16	64 BW	1-3 mm	16,75
54010.063.030	GF, Orbitalum	▲ 63	1,2	16	100 BW	0,6-1,5 mm	14,90
54010.068.010	GF, Orbitalum	▲ 68	1,6	16	44 BW	2-7 mm	18,10
54010.068.030	GF, Orbitalum	▲ 68	1,6	16	84 BW	0,8-2,5 mm	18,10
54010.075.010	GF, Orbitalum	▲ 75	2,0	16	32 BW	6-10 mm	21,90

Auslaufartikel! Ersatzartikel siehe oben Artikel 5.3980 / 5.3990
Discontinued! Alternative article see above article 5.3980 / 5.3990

Orbitale Rohrkreissägeblätter für: Georg Fischer (GF), Orbitalum, Exact
 Orbital pipe cutting circular saw blades for: Georg Fischer (GF), Orbitalum, Exact

Art. **5.3950**



Kreissägeblatt **Hartmetall-bestückt** zum Sägen in Rohre aus: **Stahl, Kupfer, Aluminium, Kunststoff**

Carbide tipped circular saws for cutting in pipes made of: **Steel, copper, aluminium, plastics**

Art.	Passend für Maschine Suitable for machine					€
53950.140.010	Georg Fischer (GF) + Orbitalum Scorp 220/360 Exact PC 170, 170E, 220E, 200, 3650	▲ 140	1,8/1,4	62	46 WZ	35,55
53950.140.020	Georg Fischer (GF) + Orbitalum Scorp 220/360 Exact PC 170, 170E, 220E, 200, 3650	● 140	1,8/1,4	62	48 WWF	40,55
53950.165.010	Exact PC 280E, 360E	● 165	1,8/1,4	62	54 WWF	56,45

Orbitale Rohrkreissägeblätter für: Georg Fischer (GF), Orbitalum, Exact
 Orbital pipe cutting circular saw blades for: Georg Fischer (GF), Orbitalum, Exact

Art. **5.3960**



Kreissägeblatt **Cermet (Keramik)** bestückt für **höchste Standzeit**. Zum Sägen in Rohre aus: **Edelstahl, Säurebeständiger Stahl, Stahl, Kupfer, Aluminium, Kunststoff**

Circular saw blades **Cermet (Ceramic)** tipped for **maximum tool life**. For cutting in pipes made of: **Stainless steel, acid-resistant steel, steel, copper, aluminium, plastic**

Art.	Passend für Maschine Suitable for machine					€
53960.140.020	Georg Fischer (GF) + Orbitalum Scorp 220/360 Exact PC 170, 170E, 220E, 200, 3650	● 140	1,8/1,4	62	48 WWF	52,85
53960.165.010	Exact PC 280E, 360E	● 165	1,8/1,4	62	54 WWF	60,95

Orbitale Rohrkreissägeblätter für: Axxair, Georg Fischer (GF), Protem, Orbitalum
 Orbital pipe cutting circular saw blades for: Axxair, Georg Fischer (GF), Protem, Orbitalum

Art. **5.3965**



Kreissägeblatt **Cermet (Keramik)** bestückt für **höchste Standzeit**. Zum Sägen in Rohre aus: **Edelstahl, Säurebeständiger Stahl, Stahl, Kupfer, Aluminium, Kunststoff**

Circular saw blades **Cermet (Ceramic)** tipped for **maximum tool life**. For cutting in pipes made of: **Stainless steel, acid-resistant steel, steel, copper, aluminium, plastic**

Art.	Passend für Maschine Suitable for machine					Hinweis Comment	€
53965.063.010	Axxair, GF, Protem, Orbitalum	● 63	2,0/1,6	16	28 BW	Für Stahl, Ne-Metalle, Kunststoffe mit Wandstärke 2-7 mm For steel, non ferrous metals, plastics with wall thickness 2-7 mm	36,85
53965.063.020	Axxair, GF, Protem, Orbitalum	● 63	1,8/1,4	16	32 BW	Für alle oben genannten Materialien mit Wandstärke 1-3 mm For all above mentioned materials with wall thickness 1-3 mm	38,45
53965.068.010	Axxair, GF, Protem, Orbitalum	● 68	2,0/1,6	16	28 BW	Für Stahl, Ne-Metalle, Kunststoffe mit Wandstärke 2-7 mm For steel, non ferrous metals, plastics with wall thickness 2-7 mm	37,15
53965.068.020	Axxair, GF, Protem, Orbitalum	● 68	1,8/1,4	16	32 BW	Für alle oben genannten Materialien mit Wandstärke 1-3 mm For all above mentioned materials with wall thickness 1-3 mm	38,75
53965.090.010	Axxair, GF, Protem, Orbitalum	● 90	2,2/1,8	16	28 BW	Für Stahl, Ne-Metalle, Kunststoffe mit Wandstärke 2-7 mm For steel, non ferrous metals, plastics with wall thickness 2-7 mm	40,05
53965.090.020	Axxair, GF, Protem, Orbitalum	● 90	2,0/1,6	16	36 BW	Für alle oben genannten Materialien mit Wandstärke 1-3 mm For all above mentioned materials with wall thickness 1-3 mm	43,25
53965.125.010	Axxair, GF, Protem, Orbitalum	● 125	1,5/1,2	16	52 BW	Für alle oben genannten Materialien mit Wandstärke 1-3 mm For all above mentioned materials with wall thickness 1-3 mm	59,25

Diamantbestreutes Blatt: Georg Fischer (GF), Orbitalum, Exact
 Diamond grit blade: Georg Fischer (GF), Orbitalum, Exact

Art. **5.3970**



Diamantbestreutes Blatt zum Trennen von Rohre aus: **Gusseisen, Sphäroguss (GGG), Gusseisen mit Betonschicht, Glasfaser (GFK), Kohlefaser (CFK)**

Diamond-Grit circular saw blades for cutting in pipes made of: **Cast iron, Ductile cast iron (GGG), Cast iron with layer of concrete, fiber glass (FRP), carbon fiber (CFRP)**

Art.	Passend für Maschine Suitable for machine					€
53970.140.010	Georg Fischer (GF) + Orbitalum Scorp 220/360 Exact PC 170, 170E, 220E, 200, 3650	● 140	2,7/1,5	62		55,45
53970.165.010	Exact PC 280E, 360E	● 165	2,7/1,5	62		67,00

- 1
- 2
- 3
- 4
- 5
- 6
- 7
- 8
- 9
- 10

Art.
100
101
102

Art. **11.1530**

Nut-Kreissägeblätter · Set 3-Teilig · Verstellbar

Grooving circular saw blades · Set 3-parts · adjustable

GOLD-STAR LINE

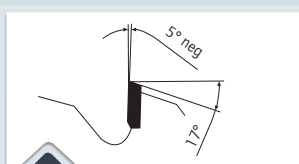
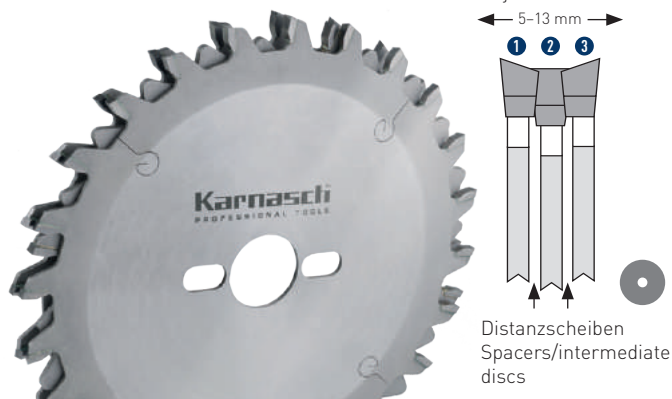

- 1 Einseitig spitz Rechts/One side acute right
- 2 Flachzahn mit Abweiser/Flat tooth with chip limiter
- 3 Einseitig spitz links/One side acute left

MASCHINE · MACHINE

Zu verwenden auf Formatkreissägen, Tischkreissägen, Kappsägen.

For use on table (bench) saws. Panel sizing saws, mitre saws.

✓ OPTIMAL · OPTIMAL ✓ GUT · GOOD ✓ MÖGLICH · POSSIBLE

✓		Weichholz, Hartholz, Exotenholz, Quer	Soft wood, hard wood, and exotic wood across the grain
✓		Weichholz, Hartholz, Exotenholz Längs	Soft wood, hard wood, and exotic wood along the grain
✓		Leimholz, Tischler- und Furniersperrholz, Schichtholzplatten	Bonded wood, blockboard and veneer plywood, laminated wood
✓		Spanplatten, Hartfaserplatten, Platten ohne Belag LDF, MDF, HDF	Chipboard, hard fibre board, boards without laminate LDF, MDF, HDF
✓		Spanplatten, Hartfaserplatten Kunststoff beschichtet/furniert, MDF, HDF	Chipboard, hard fibre board, plastic-coated/veneered, MDF, HDF

ANWENDUNG · APPLICATION

Zum präzisen Nuten von Holz, Sperrholz, Spanplatten oder MDF – auch beschichtet oder furniert. Verstellbar in 0,1 mm Schritten.

Das Set besteht aus:

- 1 Randsägeblatt rechts 24/30 Zähne
- 2 Zerspanersägeblatt 4/5 Zähne
- 3 Randsägeblatt links 24/30 Zähne

+ Distanzscheiben: 2x1,0 mm, 2x0,5 mm, 2x0,3 mm, 4x0,2 mm, 4x0,1 mm

For high precision grooves in wood, plywood, chipboard or MDF – also laminated or veneered. Adjustable in 0,1mm steps.

The Set contains:

- 1 Outer blade right 24/30 teeth
- 2 Hogger blade 4/5 teeth
- 3 Outer blade left 24/30 teeth

+ Spacers/intermediate discs: 2x1,0mm, 2x0,5mm, 2x0,3mm, 4x0,2mm, 4x0,1mm

Art.							€
111530.200.010	• 200	5-13	4-12	30	24 1 + 4 2 + 24 3	UNI	512,10
111530.250.010	• 250	5-13	4-12	30	30 1 + 5 2 + 30 3	UNI	512,10



Video

1

2

3

4

5

6

7

8

9

10

Art.
100
101
102



Geeignet für · Suitable for

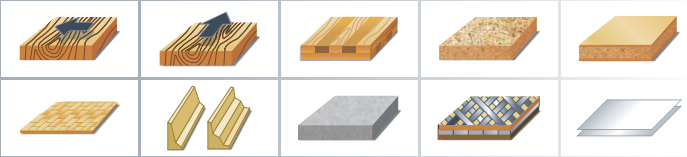

Siehe Seite 622/623 · See page 622/623

Das Allrounder-Sägeblatt für Plattenwerkstoffe.
The all-round blade for panel materials.

POWER.
PRECISION.
PERFORMANCE.

www.karnasch.tools

Karnasch®
PROFESSIONAL TOOLS

1



2



3



4



5



6



7



8



9





10

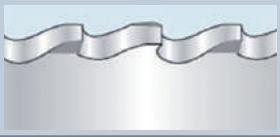

Art.
100
101
102

Zahnformen Tooth shapes

BW	Zum Sägen von Profilen und Röhren. For cutting profile and pipes.	
HZ	Zum Sägen von Vollmaterial und Rohre, Profile mit dickeren Wandstärken > 3 mm For cutting solid material and thicker profiles, pipes > 3mm	
BR	Spezialverzahnung zum Sägen von Profilen und Röhren. Im Vergleich zur Zahnform BW hat diese die doppelte Anzahl von Zahnflanken im Eingriff. Daraus resultiert weitaus höhere Standzeit und saubere Schnittflächen. Preis und Lieferung auf Anfrage. Special geometry for cutting pipes and profiles. In comparison to tooth shape BW has this BR shape double the number of cutting edges. This results to a much higher number of cuts and smooth surface finish. Price and time of delivery on request.	

Empfohlene Zähnezahl zum Sägen von Vollmaterial Recommended number of teeth for cutting solid material

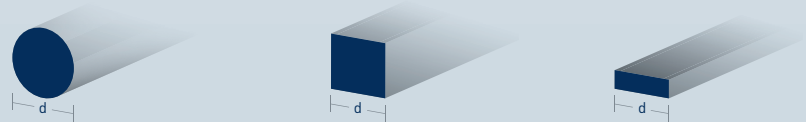

Querschnitt Crosscut d mm	Zahnteilung Pitch	Zahnform Tooth shape	Ø mm	Ø mm	Ø mm	Ø mm	Ø mm	Ø mm	Ø mm	Ø mm	Ø mm	Ø mm	Ø mm	Ø mm	Ø mm
			175	200	250	275	300	315	350	370	400	425	450	500	560
			*40 mm	*45 mm	*60 mm	*65 mm	*70 mm	*75 mm	*80 mm	*86 mm	*96 mm	*106 mm	*112 mm	*128 mm	*145 mm
10 mm	5	HZ	110	130	160	180	180	200	220	220	250	260	280	310	350
20 mm	6	HZ	90	100	128	140	160	160	180	190	200	220	230	260	300
30 mm	8	HZ	70	80	100	110	120	120	140	140	160	160	180	200	220
50 mm	8	HZ			100	90	120	120	140	140	160	160	180	200	220
70 mm	10	HZ					94	100	110	110	120	130	140	160	180
90 mm	12	HZ					80	80	90	90	110	110	120	130	150
110 mm	14	HZ								80	80	80	90	100	120
130 mm	14	HZ									80	80	90	100	120
150 mm	16	HZ											80	90	100
160 mm	16	HZ												90	100
180 mm	18	HZ												80	90

* Maximaler Schnittbereich · Maximum cutting capacity

Empfohlene Zähnezahl zum Sägen von Röhren und Profilen Recommended number of teeth for cutting pipes and profiles

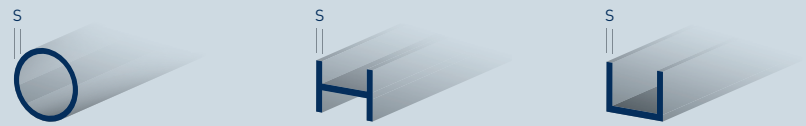

Wandstärke Wall thickness S mm	Zahnteilung Pitch	Zahnform Tooth shape	Ø mm	Ø mm	Ø mm	Ø mm	Ø mm	Ø mm	Ø mm	Ø mm	Ø mm	Ø mm	Ø mm	Ø mm	Ø mm
			175	200	250	275	300	315	350	370	400	425	450	500	560
			*40 mm	*45 mm	*60 mm	*65 mm	*70 mm	*75 mm	*80 mm	*86 mm	*96 mm	*106 mm	*112 mm	*128 mm	*145 mm
0,5 mm	3	BW	180	200	250	280	300	320	350	380					
1,0 mm	4	BW, BR	140	160	200	220	220	240	280	290	310	320	350	390	
2,0 mm	4,5	BW, BR	120	140	180	200	210	230	250	260	280	290	310	350	390
3,0 mm	5	BW, BR	110	130	160	180	180	200	220	230	250	260	280	310	350
4,0 mm	6	HZ, BR	90	100	130	140	160	170	180	200	200	220	230	260	290
5,0 mm	8	HZ, BR		80	100	110	120	130	140	150	160	170	180	200	220
6,0 mm	9	HZ, BR			90	100	110	120	130	130	140	150	160	180	200
7,0 mm	10	HZ, BR						100	110	120	120	130	140	160	180
8,0 mm	11	HZ, BR											130	140	160
9,0 mm	12	HZ, BR												130	150
10,0 mm	13	HZ												120	130

* Maximaler Schnittbereich · Maximum cutting capacity



Art.
100
101
102

Schnittparameter Vollmaterial
Cutting parameters solid material



Werkstoffe Materials		fz (mm/z)		Schnittgeschwindigkeit · Cutting speed Vc (m/min)			
		Vorschub pro Zahn Feed per tooth		Art. 5.1000	Art. 5.1040	Art. 5.1300	Art. 5.1340
		Min	Max	HSS-DMo5 Dampfbehandelt Steam treated	HSS-DMo5 Kx-Beschichtet Kx-coated	HSS-Co5 Dampfbehandelt Steam treated	HSS-Co5 Kx-Beschichtet Kx-coated
Stahl · Steel	< 500 N/mm ²	0,025	0,08	30-40	30-50	-	-
	< 800 N/mm ²	0,025	0,07	20-35	25-40	-	-
	< 1200 N/mm ²	0,02	0,06	-	-	15-25	15-30
Rostfreie Stähle · Stainless steel		0,01	0,06	-	-	10-25	10-30
Guss · Cast iron		0,025	0,05	-	-	20-30	30-50
Aluminium · Aluminium		0,04	0,09	-	500-900	-	-
Bronze · Bronze		0,04	0,07	-	200-400	-	-
Kupfer · Copper		0,04	0,06	-	200-300	-	-
Messing · Brass		0,04	0,08	-	400-600	-	-
Zinklegierungen · Zinc Alloy		0,025	0,08	-	30-100	-	-
Inconel · Inconel		0,025	0,05	-	-	-	16-45
Titan · Titanium		0,02	0,05	-	-	-	15-30

Schnittparameter Rohre und Profile
Cutting parameters pipes and profiles



Werkstoffe Materials		fz (mm/z)		Schnittgeschwindigkeit · Cutting speed Vc (m/min)			
		Vorschub pro Zahn Feed per tooth		Art. 5.1000	Art. 5.1040 Art. 5.1305	Art. 5.1300	Art. 5.1340
		Min	Max	HSS-DMo5 Dampfbehandelt Steam treated	HSS-DMo5 Kx-Beschichtet Kx-coated	HSS-Co5 Dampfbehandelt Steam treated	HSS-Co5 Kx-Beschichtet Kx-coated
Stahl · Steel	< 500 N/mm ²	0,025	0,24	45-130	70-230	-	-
	< 800 N/mm ²	0,025	0,18	30-100	45-140	-	-
	< 1200 N/mm ²	0,02	0,12	-	-	15-50	25-100
Rostfreie Stähle · Stainless steel		0,01	0,12	-	-	15-45	16-80
Guss · Cast iron		0,025	0,05	-	-	15-45	30-65
Aluminium · Aluminium		0,025	0,12	-	1000-1600	-	-
Bronze · Bronze		0,04	0,07	-	200-400	-	-
Kupfer · Copper		0,04	0,06	-	200-300	-	-
Messing · Brass		0,04	0,08	-	400-600	-	-
Zinklegierungen · Zinc Alloy		0,025	0,08	-	30-100	-	-
Inconel · Inconel		0,02	0,08	-	-	-	16-45
Titan · Titanium		0,02	0,08	-	-	-	15-30

Festlegung der Schnittgeschwindigkeit Vc
Determination of cutting speed Vc

$$Vc \text{ (m/min)} = \frac{D \cdot \pi \cdot n}{1000}$$

Festlegung der Vorschubgeschwindigkeit Vf
Determination of feed rate Vf

$$Vf \text{ (mm/min)} = fz \cdot n \cdot Z$$

Festlegung der Drehzahl n
Determination

$$n \text{ (min}^{-1}\text{)} = \frac{Vc \cdot 1000}{D \cdot \pi}$$

fz (mm/z) = Vorschub pro Zahn · Feed per tooth
D (mm) = Sägendurchmesser · Saw blade diameter
Z = Anzahl der Zähne · Number of teeth
n (min⁻¹) = Drehzahl · rpm



Art.
100
101
102

Art. **5.1000**

**HSS-DMo5
(M2)-DIN 1.3343**

Dampfbehandelt
Steam treated

Seitenschlag
Side runout

Ø 200-225 = 0,15
Ø 250-300 = 0,20
Ø 315-400 = 0,25
Ø 425-450 = 0,30
Ø 500 = 0,35

Reduzierter Seitenschlag
auf Anfrage

Reduced side runout
on request



BW



HZ



BR

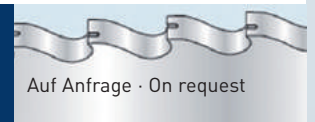

Auf Anfrage · On request

Für Stähle ≤ 800 N/mm²

HSS-DMo5: Hochlegierter Schnellarbeitsstahl mit Wolfram-, Vanadium- und Molybdänanteil für:

- Sehr gute mechanische Eigenschaften und hervorragende Festigkeit mit einer Härte von 64 ± 1HRC.

"**Dampfbehandelt**" ist eine kontrollierte Oxydierung CO₂ der Oberfläche durch anlassen der fertigen Kreissägen in erhitztem Dampf bei ca. 350 °C. Dies ergibt:

- Feine Mikroporen zur besseren Verteilung des Kühlmittels.
- Oberflächenhärte von 900 HV.
- Außergewöhnlich feine Oberflächenschicht welche die Reibung extrem verringert (Reibungskoeffizient 0,60).

Zahnwinkel

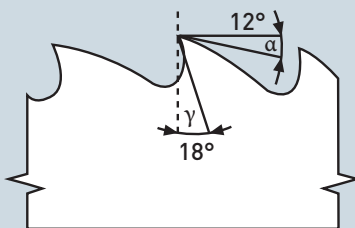

For steels ≤ 800 N/mm²

HSS-DMo5: High-speed steel which includes vanadium, wolfram and Molybdenum. This results to:

- Very good mechanical characteristics and excellent strength with a hardness of 64 ± 1HRC.

"**Steam treated**" is a surface modification by CO₂ oxidation. Circular saws are let to tempering in overheated steam of arround 350 °C. This results to:

- Microporosity arised on surface enables better coolant distribution
- Surface hardness of 900 HV.
- Extremely fine surface layer decreases the friction (antifriction). Coefficient friction 0,60.

Cutting angles

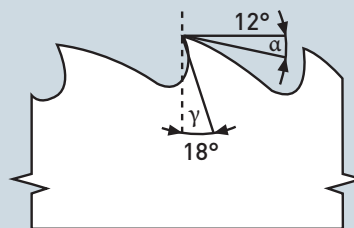

Kx Beschichtet
Kx coated

Art. 5.1040

HSS-DMo5
(M2)-DIN 1.3343

Seitenschlag
Side runout

Ø 200–225 = 0,15
Ø 250–300 = 0,20
Ø 315–400 = 0,25
Ø 425–450 = 0,30
Ø 500 = 0,35

Reduzierter Seitenschlag
auf Anfrage

Reduced side runout
on request



BW



HZ



BR

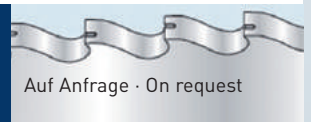

Auf Anfrage · On request

Für Stähle/Edelstähle ≤ 800 N/mm²
Aluminium, Kupfer, Messing

HSS-DMo5: Hochlegierter Schnellarbeitsstahl mit Wolfram-, Vanadium- und Molybdänanteil für:

- Sehr gute mechanische Eigenschaften und hervorragende Festigkeit mit einer Härte von 64 ± 1HRC.

Kx Beschichtung: Ergibt generell weitaus höhere Standzeiten als Dampf-behandelte Blätter (siehe Art. 5.1000).

Weiterhin:

- Gute Widerstandsfähigkeit bei hohen Bearbeitungstemperaturen. Daher geeignet auch bei ungenügender Kühlung, Minimalschmierung, Sprühnebelschmierung.
- Durch geringen Reibungskoeffizient (0,45) und hoher Oberflächenhärte von 3500 HV sind höhere Schnittgeschwindigkeiten möglich. Daher ideal für automatische Maschinen.

Zahnwinkel

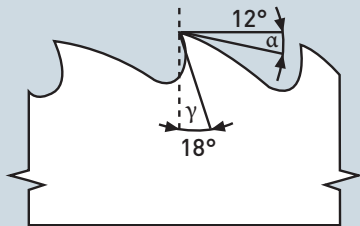

For steel/stainless steel ≤ 800 N/mm²
Aluminium, copper, brass

HSS-DMo5: High-speed steel which includes vanadium, wolfram and Molybdenum. This results to:

- Very good mechanical characteristics and excellent strength with a hardness of 64 ± 1HRC.

Kx coating: Provides much longer tool life than steam treated blades (see Art. 5.1000).

Furthermore:

- High resistance in high work temperatures. Therefore ideal also in cuts with insufficient cooling, minimal cooling, spray oil (mist).
- Due to low friction coefficient (0,45) and high surface hardness of 3500 HV suitable for higher cutting speed. Therefore ideal for automatic machines.

Cutting angles

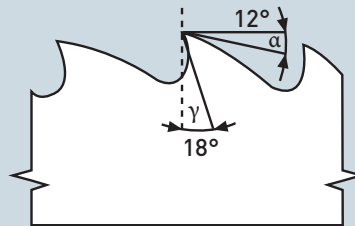

Video



681

1



2



3



4



5



6



7



8



9



10



Art.
100
101
102

Art. **5.1300**

HSS-Co5 Cobalt 5%
(M35)-DIN 1.3243

Dampfbehandelt
Steam treated

Seitenschlag
Side runout

Ø 200-225 = 0,15
Ø 250-300 = 0,20
Ø 315-400 = 0,25
Ø 425-450 = 0,30
Ø 500 = 0,35

Reduzierter Seitenschlag
auf Anfrage

Reduced side runout
on request



BW



HZ



BR



Auf Anfrage · On request

Für Stähle/Edelstähle ≤ 1200 N/mm²
Guss, Bronze, Zinklegierungen, Inconel

HSS-Co5: Hochlegierter Schnellarbeitsstahl mit Wolfram-, Molybdän- und **Kobaltanteile**. Kobalt verhindert das Kornwachstum bei hohen Betriebstemperaturen. Dadurch behält der Stahl seine Härte. Diese Eigenschaften sind erforderlich wenn **harte** und **hochlegierte** Werkstoffe wie z.B. Edelstahl geschnitten werden sollen, welche im Schneidbereich hohe Temperaturen erzeugen.

Härte des Stahls: 65 ± 1HRC.

“**Dampfbehandelt**” ist eine kontrollierte Oxydierung CO₂ der Oberfläche durch anlassen der fertigen Kreissägen in erhitztem Dampf bei ca. 350 °C. Dies ergibt:

- Feine Mikroporen zur besseren Verteilung des Kühlmittels.
- Oberflächenhärte von 900 HV.
- Außergewöhnlich feine Oberflächenschicht welche die Reibung extrem verringert (Reibungskoeffizient 0,60).

Zahnwinkel

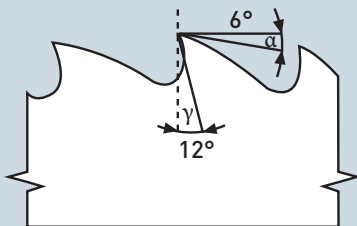

For steel/stainless steel ≤ 1200 N/mm²
Cast iron, bronze, zinc alloy, inconel

HSS-Co5: Strongly alloyed high speed steel with content of wolfram, molybdenum and **cobalt**. Cobalt obstructs critical grain growth and above all, maintains an excellent degree of hardness at high operating temperatures. These characteristics are very important when cutting very high-alloy materials such as stainless steel and very hard metals, which tend to develop high temperatures in the cutting zone.

Hardness of this steel: 65 ± 1HRC.

“**Steam treated**” is a surface modification by CO₂ oxidation. Circular saws are let to tempering in overheated steam of arround 350 °C. This results to:

- Microporosity arised on surface enables better coolant distribution
- Surface hardness of 900 HV.
- Extremely fine surface layer decreases the friction (antifriction). Coefficient friction 0,60.

Cutting angles

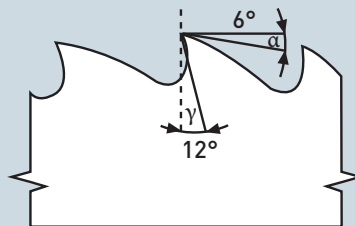

Art. 100 101 102



Kx Beschichtet
Kx coated

Art. 5.1340

HSS-Co5 Cobalt 5%
(M35)-DIN 1.3243

Seitenschlag
Side runout

Ø 200-225 = 0,15
Ø 250-300 = 0,20
Ø 315-400 = 0,25
Ø 425-450 = 0,30
Ø 500 = 0,35

Reduzierter Seitenschlag
auf Anfrage

Reduced side runout
on request



BW



HZ



BR



Auf Anfrage · On request

Für Stähle/Edelstähle ≤ 1200 N/mm²
Guss, Bronze, Zinklegierungen, Inconel

HSS-Co5: Hochlegierter Schnellarbeitsstahl mit Wolfram-, Molybdän- und Kobaltanteile. Kobalt verhindert das Kornwachstum bei hohen Betriebstemperaturen. Dadurch behält der Stahl seine Härte. Diese Eigenschaften sind erforderlich wenn **harte** und **hochlegierte** Werkstoffe wie z.B. Edelstahl geschnitten werden sollen, welche im Schneidbereich hohe Temperaturen erzeugen.

Härte des Stahls: 65 ± 1HRC.

Kx Beschichtung: Ergibt generell weitaus höhere Standzeiten als Dampf-behandelte Blätter (siehe Art. 5.1300).

Weiterhin:

- Gute Widerstandsfähigkeit bei hohen Bearbeitungstemperaturen. Daher geeignet auch bei ungenügender Kühlung, Minimalschmierung, Sprühnebelschmierung.
- Durch geringen Reibungskoeffizient (0,50) und hoher Oberflächenhärte von 3500 HV sind höhere Schnittgeschwindigkeiten möglich. Daher ideal für automatische Maschinen.

Zahnwinkel

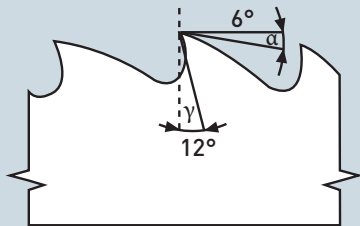

For steel/stainless steel ≤ 1200 N/mm²
Cast iron, bronze, zinc alloy, inconel

HSS-Co5: Strongly alloyed high speed steel with content of wolfram, molybdenum and **cobalt**. Cobalt obstructs critical grain growth and above all, maintains an excellent degree of hardness at high operating temperatures. These characteristics are very important when cutting very high-alloy materials such as stainless steel and very hard metals, which tend to develop high temperatures in the cutting zone.

Hardness of this steel: 65 ± 1HRC.

Kx coating: Provides much longer tool life than steam treated blades (see Art. 5.1300).

Furthermore:

- High resistance in high work temperatures. Therefore ideal also in cuts with insufficient cooling, minimal cooling, spray oil (mist).
- Due to low friction coefficient (0,50) and high surface hardness of 3500 HV suitable for higher cutting speed. Therefore ideal for automatic machines.

Cutting angles

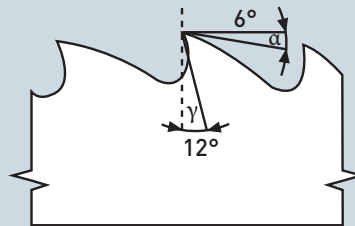

1



2



3



4



5



6



7



8



9



10



Video

Art. **5.1305**

**HSS-DMo5
(M2)-DIN 1.3343**

Kx Beschichtet + Profil Geometrie
Kx coated + profile geometry

Seitenschlag
Side runout

Ø 200-225 = 0,15
Ø 250-300 = 0,20
Ø 315-400 = 0,25
Ø 425-450 = 0,30
Ø 500 = 0,35

Reduzierter Seitenschlag
auf Anfrage

Reduced side runout
on request



BR

Auf Anfrage · On request

Beste Schneidgeometrie zum sägen von Rohren und Profilen aus Stahl/Edelstahl ≤ 800 N/mm² sowie aus Aluminium, Kupfer, Messing

Preis und Lieferzeit auf Anfrage

HSS-DMo5: Hochlegierter Schnellarbeitsstahl mit Wolfram-, Vanadium- und Molybdänanteil für:

- Sehr gute mechanische Eigenschaften und hervorragende Festigkeit mit einer Härte von $64 \pm 1\text{HRC}$.

Kx Beschichtung: Ergibt generell weitaus höhere Standzeiten als Dampf-behandelte Blätter (siehe Art. 5.1000).

Weiterhin:

- Gute Widerstandsfähigkeit bei hohen Bearbeitungstemperaturen. Daher geeignet auch bei ungenügender Kühlung, Minimalschmierung, Sprühnebelschmierung.
- Durch geringen Reibungskoeffizient (0,45) und hoher Oberflächenhärte von 3500 HV sind höhere Schnittgeschwindigkeiten möglich. Daher Ideal für automatische Maschinen.

Zahnwinkel

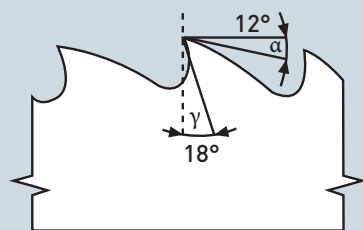

Profil Geometrie (BR)



Best cutting geometry for cutting pipes, profiles made of steel/stainless steel ≤ 800 N/mm² and made of aluminium, copper, brass

Price and time of delivery on request

HSS-DMo5: High-speed steel which includes vanadium, wolfram and Molybdenum. This results to:

- Very good mechanical characteristics and excellent strength with a hardness of $64 \pm 1\text{HRC}$.

Kx coating: Provides much longer tool life than steam treated blades (see Art. 5.1000).

Furthermore:

- High resistance in high work temperatures. Therefore ideal also in cuts with insufficient cooling, minimal cooling, spray oil (mist).
- Due to low friction coefficient (0,45) and high surface hardness of 3500 HV suitable for higher cutting speed. Therefore ideal for automatic machines.

Cutting angles

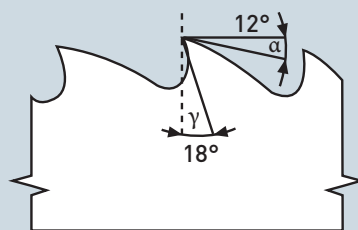

Profile Geometry (BR)



Anwendung siehe Seite
Application see page

					680	681	682	683				
					Art. 5.1000 HSS-DMo5 Dampfbehandelt Steam treated	Art. 5.1040 HSS-DMo5 Kx-Beschichtet Kx-coated	Art. 5.1300 HSS-Co5 Dampfbehandelt Steam treated	Art. 5.1340 HSS-Co5 Kx-Beschichtet Kx-coated				
					Art.	€	Art.	€	Art.	€	Art.	€
					● 51000.200.010	47,95	-	-	-	-	-	-
200	1,2	32	0	2-8-45+2-9-50+2-11-63	● 51000.200.020	52,10	-	-	-	-	-	-
200	1,2	32	200 BW	2-8-45+2-9-50+2-11-63	● 51000.200.030	52,10	-	-	-	-	-	-
200	1,2	32	160 BW	2-8-45+2-9-50+2-11-63	● 51000.200.040	52,10	-	-	-	-	-	-
200	1,2	32	140 BW	2-8-45+2-9-50+2-11-63	● 51000.200.050	44,05	-	-	-	-	-	-
200	1,6	32	0	2-8-45+2-9-50+2-11-63	● 51000.200.060	47,90	-	-	-	-	-	-
200	1,6	32	200 BW	2-8-45+2-9-50+2-11-63	● 51000.200.070	47,90	-	-	-	-	-	-
200	1,6	32	160 BW	2-8-45+2-9-50+2-11-63	● 51000.200.080	47,90	-	-	-	-	-	-
200	1,6	32	100 HZ	2-8-45+2-9-50+2-11-63	● 51000.200.090	43,05	-	-	-	-	-	-
200	1,8	32	0	2-8-45+2-9-50+2-11-63	● 51000.200.100	46,80	-	-	-	-	-	-
200	1,8	32	200 BW	2-8-45+2-9-50+2-11-63	● 51000.200.110	46,80	-	-	-	-	-	-
200	1,8	32	160 BW	2-8-45+2-9-50+2-11-63	▲ 51000.200.120	47,00	-	-	-	-	-	-
200	1,8	32	128 BW	2-8-45+2-9-50+2-11-63	● 51000.200.130	45,10	-	-	-	-	-	-
200	2,0	32	0	2-8-45+2-9-50+2-11-63	● 51000.200.140	49,05	-	-	-	-	-	-
200	2,0	32	200 BW	2-8-45+2-9-50+2-11-63	● 51000.200.150	49,05	-	-	-	-	-	-
200	2,0	32	160 BW	2-8-45+2-9-50+2-11-63	● 51000.200.160	49,05	-	-	-	-	-	-
200	2,0	32	130 BW	2-8-45+2-9-50+2-11-63	● 51000.200.170	49,05	-	-	-	-	-	-
200	2,0	32	100 HZ	2-8-45+2-9-50+2-11-63	▲ 51000.200.180	45,60	-	-	-	-	-	-
200	2,0	32	0	-	▲ 51000.200.190	48,00	-	-	-	-	-	-
200	2,0	32	200 BW	-	▲ 51000.200.200	48,00	-	-	-	-	-	-
200	2,0	32	160 BW	-	▲ 51000.200.210	48,00	-	-	-	-	-	-
200	2,0	32	130 BW	-	● 51000.200.220	49,05	-	-	-	-	-	-
200	2,0	32	100 HZ	-	▲ 51000.210.010	46,55	-	-	▲ 51300.210.010	61,75	-	-
210	2,0	32	0	2-8-45+2-9-50+2-11-63	▲ 51000.210.020	49,00	▲ 51040.210.020	73,00	-	-	-	-
210	2,0	32	210 BW	2-8-45+2-9-50+2-11-63	-	-	▲ 51040.210.025	73,00	▲ 51300.210.025	65,00	-	-
210	2,0	32	160 BW	2-8-45+2-9-50+2-11-63	-	-	▲ 51040.210.027	73,00	-	-	-	-
210	2,0	32	120 HZ	2-8-45+2-9-50+2-11-63	-	-	-	-	-	-	-	-
210	2,0	40	0	2-8-55 + 4-11-63	▲ 51000.210.030	46,55	-	-	▲ 51300.210.030	61,75	-	-
210	2,0	40	160 BW	2-8-55 + 4-11-63	▲ 51000.210.040	49,00	▲ 51040.210.040	73,00	-	-	-	-
225	1,2	32	0	2-8-45+2-9-50+2-11-63	● 51000.225.010	58,75	-	-	-	-	-	-
225	1,2	32	220 BW	2-8-45+2-9-50+2-11-63	● 51000.225.020	63,85	-	-	-	-	-	-
225	1,2	32	180 BW	2-8-45+2-9-50+2-11-63	● 51000.225.030	63,85	-	-	-	-	-	-
225	1,2	32	160 BW	2-8-45+2-9-50+2-11-63	● 51000.225.040	63,85	-	-	-	-	-	-
225	1,6	32	0	2-8-45+2-9-50+2-11-63	● 51000.225.050	53,85	-	-	-	-	-	-
225	1,6	32	220 BW	2-8-45+2-9-50+2-11-63	● 51000.225.060	58,55	-	-	-	-	-	-
225	1,6	32	180 BW	2-8-45+2-9-50+2-11-63	● 51000.225.070	58,55	-	-	-	-	-	-
225	1,6	32	160 BW	2-8-45+2-9-50+2-11-63	● 51000.225.080	58,55	-	-	-	-	-	-
225	1,6	32	120 HZ	2-8-45+2-9-50+2-11-63	● 51000.225.090	58,55	-	-	-	-	-	-
225	1,6	40	0	2-8-55 + 4-11-63	▲ 51000.225.100	54,15	-	-	▲ 51300.225.100	61,05	-	-
225	1,6	40	180 BW	2-8-55 + 4-11-63	▲ 51000.225.110	57,00	-	-	-	-	-	-
225	1,6	40	120 HZ	2-8-55 + 4-11-63	▲ 51000.225.120	57,00	-	-	-	-	-	-
225	2,0	32	0	2 NL REMS/Roller	● 51000.225.130	47,15	-	-	-	-	-	-
225	2,0	32	220 BW	2 NL REMS/Roller	● 51000.225.140	51,25	● 51040.225.140	75,25	● 51300.225.140	66,40	-	-
225	2,0	32	180 BW	2 NL REMS/Roller	● 51000.225.150	51,25	● 51040.225.150	75,25	● 51300.225.150	66,40	-	-
225	2,0	32	120 HZ	2 NL REMS/Roller	▲ 51000.225.160	53,00	▲ 51040.225.160	74,00	-	-	-	-
225	2,0	32	0	2-8-45+2-9-50+2-11-63	● 51000.225.170	47,15	-	-	● 51300.225.170	61,05	-	-
225	2,0	32	220 BW	2-8-45+2-9-50+2-11-63	● 51000.225.180	51,25	● 51040.225.180	75,25	● 51300.225.180	66,40	-	-
225	2,0	32	180 BW	2-8-45+2-9-50+2-11-63	● 51000.225.190	51,25	● 51040.225.190	75,25	● 51300.225.190	66,40	-	-
225	2,0	32	160 HZ	2-8-45+2-9-50+2-11-63	● 51000.225.200	51,25	● 51040.225.200	75,25	● 51300.225.200	66,40	-	-
225	2,0	32	120 HZ	2-8-45+2-9-50+2-11-63	● 51000.225.210	51,25	● 51040.225.210	75,25	● 51300.225.210	66,40	-	-
225	2,0	32	90 BW	2-8-45+2-9-50+2-11-63	▲ 51000.225.220	53,00	▲ 51040.225.220	74,00	-	-	-	-
225	2,0	32	0	4-9-50 + 4-11-63	▲ 51000.225.230	50,35	-	-	-	-	-	-
225	2,0	32	220 BW	4-9-50 + 4-11-63	▲ 51000.225.240	53,00	-	-	-	-	-	-
225	2,0	32	160 BW	4-9-50 + 4-11-63	▲ 51000.225.250	53,00	-	-	-	-	-	-
225	2,0	32	120 BW	4-9-50 + 4-11-63	▲ 51000.225.260	53,00	-	-	-	-	-	-
225	2,0	32	90 HZ	4-9-50 + 4-11-63	▲ 51000.225.270	53,00	-	-	-	-	-	-
225	2,0	40	0	2-8-55 + 4-11-63	▲ 51000.225.280	50,35	-	-	▲ 51300.225.280	63,65	-	-
225	2,0	40	220 BW	2-8-55 + 4-11-63	▲ 51000.225.290	53,00	▲ 51040.225.290	74,00	▲ 51300.225.290	67,00	-	-

Weitere Abmessungen auf Anfrage · Other dimensions are available on request



Art.
100
101
102

Anwendung siehe Seite
Application see page

680



681



682



683



					Art. 5.1000 HSS-DMo5 Dampfbehandelt Steam treated		Art. 5.1040 HSS-DMo5 Kx-Beschichtet Kx-coated		Art. 5.1300 HSS-Co5 Dampfbehandelt Steam treated		Art. 5.1340 HSS-Co5 Kx-Beschichtet Kx-coated		
					Art.	€	Art.	€	Art.	€	Art.	€	
	225	2,0	40	180 BW	2-8-55 + 4-11-63	▲ 51000.225.300	53,00	▲ 51040.225.300	74,00	▲ 51300.225.300	67,00	-	
	225	2,0	40	160 BW	2-8-55 + 4-11-63	▲ 51000.225.310	53,00	▲ 51040.225.310	74,00	▲ 51300.225.310	67,00	-	
	225	2,0	40	120 HZ	2-8-55 + 4-11-63	▲ 51000.225.320	53,00	▲ 51040.225.320	74,00	▲ 51300.225.320	67,00	-	
	225	2,0	40	90 HZ	2-8-55 + 4-11-63	▲ 51000.225.330	53,00	▲ 51040.225.330	74,00	-	-	-	
	225	2,5	32	0	2-8-45+2-9-50+2-11-63	▲ 51000.225.340	60,80	-	-	-	-	-	
	225	2,5	32	220 BW	2-8-45+2-9-50+2-11-63	▲ 51000.225.350	64,00	-	-	-	-	-	
	225	2,5	32	160 BW	2-8-45+2-9-50+2-11-63	▲ 51000.225.360	64,00	-	-	-	-	-	
	225	2,5	32	120 HZ	2-8-45+2-9-50+2-11-63	▲ 51000.225.370	64,00	-	-	-	-	-	
	225	2,5	32	90 HZ	2-8-45+2-9-50+2-11-63	▲ 51000.225.380	64,00	-	-	-	-	-	
	225	2,5	40	0	2-8-55 + 4-11-63	▲ 51000.225.390	60,80	-	-	-	-	-	
	225	2,5	40	220 BW	2-8-55 + 4-11-63	▲ 51000.225.400	64,00	-	-	-	-	-	
	225	2,5	40	120 HZ	2-8-55 + 4-11-63	▲ 51000.225.410	64,00	-	-	-	-	-	
	250	1,2	32	0	2-8-45+2-9-50+2-11-63	● 51000.250.010	60,30	-	-	● 51300.250.010	73,70	-	
	250	1,2	32	240 BW	2-8-45+2-9-50+2-11-63	● 51000.250.020	65,55	-	-	-	-	-	
	250	1,2	32	200 BW	2-8-45+2-9-50+2-11-63	● 51000.250.030	65,55	-	-	-	-	-	
	250	1,2	32	180 BW	2-8-45+2-9-50+2-11-63	● 51000.250.040	65,55	-	-	-	-	-	
	250	1,2	32	160 BW	2-8-45+2-9-50+2-11-63	● 51000.250.050	65,55	-	-	-	-	-	
	250	1,6	32	0	2-8-45+2-9-50+2-11-63	● 51000.250.060	53,25	-	-	● 51300.250.060	66,20	-	
	250	1,6	32	240 BW	2-8-45+2-9-50+2-11-63	● 51000.250.070	57,85	-	-	-	-	-	
	250	1,6	32	200 BW	2-8-45+2-9-50+2-11-63	● 51000.250.080	57,85	-	-	-	-	-	
	250	1,6	32	180 BW	2-8-45+2-9-50+2-11-63	● 51000.250.090	57,85	-	-	-	-	-	
	250	1,6	32	160 BW	2-8-45+2-9-50+2-11-63	● 51000.250.100	57,85	-	-	-	-	-	
	250	1,6	32	128 HZ	2-8-45+2-9-50+2-11-63	● 51000.250.110	57,85	-	-	-	-	-	
	250	1,6	40	0	2-8-55 + 4-12-64	▲ 51000.250.120	54,15	-	-	-	-	-	
	250	1,6	40	200 BW	2-8-55 + 4-12-64	▲ 51000.250.130	57,00	-	-	-	-	-	
	250	1,6	40	128 HZ	2-8-55 + 4-12-64	▲ 51000.250.140	57,00	-	-	-	-	-	
	250	2,0	32	0	2-8-45+2-9-50+2-11-63	● 51000.250.150	50,25	-	-	● 51300.250.150	68,05	-	
	250	2,0	32	240 BW	2-8-45+2-9-50+2-11-63	● 51000.250.160	54,65	● 51040.250.160	84,05	● 51300.250.160	73,95	● 51340.250.160	99,70
	250	2,0	32	200 BW	2-8-45+2-9-50+2-11-63	● 51000.250.170	54,65	● 51040.250.170	84,05	● 51300.250.170	73,95	● 51340.250.170	99,70
	250	2,0	32	180 BW	2-8-45+2-9-50+2-11-63	● 51000.250.180	54,65	● 51040.250.180	84,05	● 51300.250.180	73,95	● 51340.250.180	99,70
	250	2,0	32	160 BW	2-8-45+2-9-50+2-11-63	● 51000.250.190	54,65	● 51040.250.190	84,05	● 51300.250.190	73,95	-	
	250	2,0	32	140 BW	2-8-45+2-9-50+2-11-63	● 51000.250.200	54,65	-	-	-	-	-	
	250	2,0	32	128 HZ	2-8-45+2-9-50+2-11-63	● 51000.250.210	54,65	● 51040.250.210	84,05	● 51300.250.210	73,95	-	
	250	2,0	32	100 HZ	2-8-45+2-9-50+2-11-63	● 51000.250.220	54,65	● 51040.250.220	84,05	● 51300.250.220	73,95	-	
	250	2,0	32	0	4-9-50 + 4-11-63	▲ 51000.250.230	50,35	-	-	▲ 51300.250.230	68,00	-	
	250	2,0	32	200 BW	4-9-50 + 4-11-63	▲ 51000.250.240	53,00	-	-	-	-	-	
	250	2,0	32	160 HZ	4-9-50 + 4-11-63	▲ 51000.250.250	53,00	-	-	-	-	-	
	250	2,0	32	128 HZ	4-9-50 + 4-11-63	▲ 51000.250.260	53,00	-	-	-	-	-	
	250	2,0	32	100 HZ	4-9-50 + 4-11-63	▲ 51000.250.270	53,00	-	-	-	-	-	
	250	2,0	40	0	2-8-55 + 4-12-64	● 51000.250.280	50,25	-	-	● 51300.250.280	68,05	-	
	250	2,0	40	240 BW	2-8-55 + 4-12-64	● 51000.250.290	54,65	● 51040.250.290	85,15	● 51300.250.290	73,95	● 51340.250.290	99,70
	250	2,0	40	200 BW	2-8-55 + 4-12-64	● 51000.250.300	54,65	● 51040.250.300	85,15	● 51300.250.300	73,95	● 51340.250.300	99,70
	250	2,0	40	180 BW	2-8-55 + 4-12-64	● 51000.250.310	54,65	● 51040.250.310	85,15	● 51300.250.310	73,95	● 51340.250.310	99,70
	250	2,0	40	160 BW	2-8-55 + 4-12-64	● 51000.250.320	54,65	● 51040.250.320	85,15	● 51300.250.320	73,95	-	
	250	2,0	40	128 HZ	2-8-55 + 4-12-64	● 51000.250.330	54,65	● 51040.250.330	85,15	● 51300.250.330	73,95	-	
	250	2,0	40	100 HZ	2-8-55 + 4-12-64	● 51000.250.340	54,65	● 51040.250.340	85,15	● 51300.250.340	73,95	-	
	250	2,5	32	0	2-8-45+2-9-50+2-11-63	● 51000.250.350	61,85	-	-	● 51300.250.350	80,40	-	
	250	2,5	32	240 BW	2-8-45+2-9-50+2-11-63	● 51000.250.360	67,25	● 51040.250.360	96,35	● 51300.250.360	87,40	● 51340.250.360	112,60
	250	2,5	32	200 BW	2-8-45+2-9-50+2-11-63	● 51000.250.370	67,25	● 51040.250.370	96,35	● 51300.250.370	87,40	● 51340.250.370	112,60
	250	2,5	32	160 BW	2-8-45+2-9-50+2-11-63	● 51000.250.380	67,25	● 51040.250.380	96,35	● 51300.250.380	87,40	● 51340.250.380	112,60
	250	2,5	32	128 HZ	2-8-45+2-9-50+2-11-63	● 51000.250.390	67,25	● 51040.250.390	96,35	● 51300.250.390	87,40	-	
	250	2,5	32	100 HZ	2-8-45+2-9-50+2-11-63	● 51000.250.400	67,25	● 51040.250.400	96,35	● 51300.250.400	87,40	-	
	250	2,5	32	0	4-9-50 + 4-11-63	▲ 51000.250.410	61,75	-	-	-	-	-	
	250	2,5	32	128 HZ	4-9-50 + 4-11-63	▲ 51000.250.420	65,00	-	-	▲ 51300.250.420	80,40	-	
	250	2,5	32	100 HZ	4-9-50 + 4-11-63	▲ 51000.250.430	65,00	-	-	-	-	-	
	250	2,5	40	0	2-8-55 + 4-12-64	● 51000.250.440	61,85	-	-	● 51300.250.440	80,40	-	
	250	2,5	40	240 BW	2-8-55 + 4-12-64	● 51000.250.450	67,25	● 51040.250.450	96,35	● 51300.250.450	87,40	-	

Weitere Abmessungen auf Anfrage · Other dimensions are available on request

686

Weitere Informationen erhalten Sie telefonisch unter +49 33675-7265-0 oder schreiben Sie eine Mail an mail@karnasch.tools.
For more informations please call +49 33675-7265-0 send a mail to mail@karnasch.tools.

Anwendung siehe Seite
Application see page

					680	681	682	683									
					Art. 5.1000 HSS-DMo5 Dampfbehandelt Steam treated		Art. 5.1040 HSS-DMo5 Kx-Beschichtet Kx-coated		Art. 5.1300 HSS-Co5 Dampfbehandelt Steam treated		Art. 5.1340 HSS-Co5 Kx-Beschichtet Kx-coated						
					Art.	€	Art.	€	Art.	€	Art.	€					
					250	2,5	40	200 BW	2-8-55 + 4-12-64	● 51000.250.460	67,25	● 51040.250.460	96,35	● 51300.250.460	87,40	-	-
					250	2,5	40	160 BW	2-8-55 + 4-12-64	● 51000.250.470	67,25	● 51040.250.470	96,35	● 51300.250.470	87,40	-	-
					250	2,5	40	128 HZ	2-8-55 + 4-12-64	● 51000.250.480	67,25	● 51040.250.480	96,35	● 51300.250.480	87,40	-	-
					250	2,5	40	100 HZ	2-8-55 + 4-12-64	● 51000.250.490	67,25	● 51040.250.490	96,35	● 51300.250.490	87,40	-	-
					275	1,6	32	0	2-8-45+2-9-50+2-11-63	● 51000.275.010	59,05	-	-	● 51300.275.010	78,85	-	-
					275	1,6	32	280 BW	2-8-45+2-9-50+2-11-63	● 51000.275.020	64,15	-	-	-	-	-	-
					275	1,6	32	220 BW	2-8-45+2-9-50+2-11-63	● 51000.275.030	64,15	-	-	-	-	-	-
					275	1,6	32	180 BW	2-8-45+2-9-50+2-11-63	● 51000.275.040	64,15	-	-	-	-	-	-
					275	2,0	32	0	2-8-45+2-9-50+2-11-63	● 51000.275.050	61,05	-	-	● 51300.275.050	81,15	-	-
					275	2,0	32	280 BW	2-8-45+2-9-50+2-11-63	● 51000.275.060	66,40	● 51040.275.060	101,65	● 51300.275.060	88,25	● 51340.275.060	117,65
					275	2,0	32	220 BW	2-8-45+2-9-50+2-11-63	● 51000.275.070	66,40	● 51040.275.070	101,65	● 51300.275.070	88,25	● 51340.275.070	117,65
					275	2,0	32	200 BW	2-8-45+2-9-50+2-11-63	● 51000.275.080	66,40	● 51040.275.080	101,65	● 51300.275.080	88,25	● 51340.275.080	117,65
					275	2,0	32	180 BW	2-8-45+2-9-50+2-11-63	● 51000.275.090	66,40	● 51040.275.090	101,65	● 51300.275.090	88,25	-	-
					275	2,0	32	160 BW	2-8-45+2-9-50+2-11-63	● 51000.275.100	66,40	● 51040.275.100	101,65	● 51300.275.100	88,25	-	-
					275	2,0	32	140 HZ	2-8-45+2-9-50+2-11-63	● 51000.275.110	66,40	● 51040.275.110	101,65	● 51300.275.110	88,25	-	-
					275	2,0	32	110 HZ	2-8-45+2-9-50+2-11-63	● 51000.275.120	66,40	● 51040.275.120	101,65	● 51300.275.120	88,25	-	-
					275	2,0	32	0	4-9-50 + 4-11-63	▲ 51000.275.130	60,80	-	-	-	-	-	-
					275	2,0	32	220 BW	4-9-50 + 4-11-63	▲ 51000.275.140	64,00	-	-	-	-	-	-
					275	2,0	32	160 BW	4-9-50 + 4-11-63	● 51000.275.160	66,40	-	-	-	-	-	-
					275	2,0	32	140 HZ	4-9-50 + 4-11-63	▲ 51000.275.170	64,00	-	-	-	-	-	-
					275	2,0	32	110 HZ	4-9-50 + 4-11-63	▲ 51000.275.180	64,00	-	-	-	-	-	-
					275	1,6	40	0	2-8-55 + 4-12-64	● 51000.275.190	59,05	-	-	● 51300.275.190	78,85	-	-
					275	1,6	40	280 BW	2-8-55 + 4-12-64	● 51000.275.200	64,15	-	-	-	-	-	-
					275	1,6	40	220 BW	2-8-55 + 4-12-64	● 51000.275.210	64,15	-	-	-	-	-	-
					275	1,6	40	180 BW	2-8-55 + 4-12-64	● 51000.275.220	64,15	-	-	-	-	-	-
					275	2,0	40	0	2-8-55 + 4-12-64	● 51000.275.230	61,05	-	-	● 51300.275.230	81,15	-	-
					275	2,0	40	280 BW	2-8-55 + 4-12-64	● 51000.275.240	66,40	● 51040.275.240	101,65	● 51300.275.240	88,25	● 51340.275.240	117,65
					275	2,0	40	220 BW	2-8-55 + 4-12-64	● 51000.275.250	66,40	● 51040.275.250	101,65	● 51300.275.250	88,25	● 51340.275.250	117,65
					275	2,0	40	200 BW	2-8-55 + 4-12-64	● 51000.275.260	66,40	● 51040.275.260	101,65	● 51300.275.260	88,25	● 51340.275.260	117,65
					275	2,0	40	180 BW	2-8-55 + 4-12-64	● 51000.275.270	66,40	● 51040.275.270	101,65	● 51300.275.270	88,25	-	-
					275	2,0	40	160 BW	2-8-55 + 4-12-64	● 51000.275.280	66,40	● 51040.275.280	101,65	● 51300.275.280	88,25	-	-
					275	2,0	40	140 HZ	2-8-55 + 4-12-64	● 51000.275.290	66,40	● 51040.275.290	101,65	● 51300.275.290	88,25	-	-
					275	2,5	32	0	2-8-45+2-9-50+2-11-63	● 51000.275.300	65,70	-	-	● 51300.275.300	82,45	-	-
					275	2,5	32	280 BW	2-8-45+2-9-50+2-11-63	● 51000.275.310	71,45	● 51040.275.310	103,65	● 51300.275.310	89,65	● 51340.275.310	123,35
					275	2,5	32	220 BW	2-8-45+2-9-50+2-11-63	● 51000.275.320	71,45	● 51040.275.320	103,65	● 51300.275.320	89,65	● 51340.275.320	123,35
					275	2,5	32	180 BW	2-8-45+2-9-50+2-11-63	● 51000.275.330	71,45	● 51040.275.330	103,65	● 51300.275.330	89,65	● 51340.275.330	123,35
					275	2,5	32	160 BW	2-8-45+2-9-50+2-11-63	● 51000.275.340	71,45	● 51040.275.340	103,65	● 51300.275.340	89,65	-	-
					275	2,5	32	140 HZ	2-8-45+2-9-50+2-11-63	● 51000.275.350	71,45	● 51040.275.350	103,65	● 51300.275.350	89,65	-	-
					275	2,5	32	120 HZ	2-8-45+2-9-50+2-11-63	-	-	▲ 51040.275.355	100,00	-	-	-	-
					275	2,5	32	110 HZ	2-8-45+2-9-50+2-11-63	▲ 51000.275.360	69,00	▲ 51040.275.360	100,00	▲ 51300.275.360	90,00	-	-
					275	2,5	32	90 HZ	2-8-45+2-9-50+2-11-63	▲ 51000.275.370	69,00	▲ 51040.275.370	100,00	▲ 51300.275.370	90,00	-	-
					275	2,5	32	0	4-9-50 + 4-11-63	▲ 51000.275.380	65,55	-	-	▲ 51300.275.380	82,45	-	-
					275	2,5	32	280 BW	4-9-50 + 4-11-63	▲ 51000.275.390	69,00	-	-	-	-	-	-
					275	2,5	32	220 BW	4-9-50 + 4-11-63	▲ 51000.275.400	69,00	-	-	-	-	-	-
					275	2,5	32	180 HZ	4-9-50 + 4-11-63	▲ 51000.275.410	69,00	-	-	-	-	-	-
					275	2,5	32	160 BW	4-9-50 + 4-11-63	▲ 51000.275.420	69,00	-	-	-	-	-	-
					275	2,5	32	140 HZ	4-9-50 + 4-11-63	▲ 51000.275.430	69,00	-	-	-	-	-	-
					275	2,5	32	120 HZ	4-9-50 + 4-11-63	▲ 51000.275.440	69,00	-	-	-	-	-	-
					275	2,5	32	110 HZ	4-9-50 + 4-11-63	▲ 51000.275.450	69,00	-	-	-	-	-	-
					275	2,5	32	90 HZ	4-9-50 + 4-11-63	▲ 51000.275.460	69,00	-	-	-	-	-	-
					275	2,5	40	0	2-8-55 + 4-12-64	● 51000.275.470	65,70	-	-	● 51300.275.470	82,45	-	-
					275	2,5	40	280 BW	2-8-55 + 4-12-64	● 51000.275.480	71,45	● 51040.275.480	103,65	● 51300.275.480	89,65	● 51340.275.480	123,35
					275	2,5	40	220 BW	2-8-55 + 4-12-64	● 51000.275.490	71,45	● 51040.275.490	103,65	● 51300.275.490	89,65	● 51340.275.490	123,35
					275	2,5	40	180 BW	2-8-55 + 4-12-64	● 51000.275.500	71,45	● 51040.275.500	103,65	● 51300.275.500	89,65	● 51340.275.500	123,35
					275	2,5	40	160 BW	2-8-55 + 4-12-64	● 51000.275.510	71,45	● 51040.275.510	103,65	● 51300.275.510	89,65	-	-
					275	2,5	40	140 HZ	2-8-55 + 4-12-64	● 51000.275.520	71,45	● 51040.275.520	103,65	● 51300.275.520	89,65	-	-
					275	2,5	40	120 HZ	2-8-55 + 4-12-64	● 51000.275.530	71,45	▲ 51040.275.530	100,00	▲ 51300.275.530	90,00	-	-

Weitere Abmessungen auf Anfrage · Other dimensions are available on request



Art.
100
101
102

Anwendung siehe Seite
Application see page

680



681



682



683



Art.	€	Art. 5.1000		Art. 5.1040		Art. 5.1300		Art. 5.1340				
		Art.	€	Art.	€	Art.	€	Art.	€			
275	2,5	40	110 HZ	2-8-55 + 4-12-64	● 51000.275.540	71,45	▲ 51040.275.540	100,00	▲ 51300.275.540	90,00	-	-
275	2,5	40	90 HZ	2-8-55 + 4-12-64	● 51000.275.550	71,45	▲ 51040.275.550	100,00	▲ 51300.275.550	90,00	-	-
275	3,0	32	0	2-8-45+2-9-50+2-11-63	▲ 51000.275.560	86,45	-	-	-	-	-	-
275	3,0	32	220 BW	2-8-45+2-9-50+2-11-63	▲ 51000.275.570	91,00	-	-	-	-	-	-
275	3,0	32	140 HZ	2-8-45+2-9-50+2-11-63	▲ 51000.275.580	91,00	-	-	-	-	-	-
275	3,0	32	110 HZ	2-8-45+2-9-50+2-11-63	▲ 51000.275.590	91,00	-	-	-	-	-	-
275	3,0	32	0	4-9-50 + 4-11-63	▲ 51000.275.600	86,45	-	-	-	-	-	-
275	3,0	40	0	2-8-55 + 4-12-64	▲ 51000.275.610	86,45	-	-	-	-	-	-
275	3,0	40	220 BW	2-8-55 + 4-12-64	▲ 51000.275.620	91,00	-	-	-	-	-	-
275	3,0	40	180 BW	2-8-55 + 4-12-64	▲ 51000.275.630	91,00	-	-	-	-	-	-
275	3,0	40	140 HZ	2-8-55 + 4-12-64	▲ 51000.275.640	91,00	-	-	-	-	-	-
275	3,0	40	110 HZ	2-8-55 + 4-12-64	▲ 51000.275.650	91,00	-	-	-	-	-	-
300	1,6	32	0	2-8-45+2-9-50+2-11-63	● 51000.300.010	83,25	-	-	● 51300.300.010	110,80	-	-
300	1,6	32	300 BW	2-8-45+2-9-50+2-11-63	● 51000.300.020	90,45	-	-	-	-	-	-
300	1,6	32	220 BW	2-8-45+2-9-50+2-11-63	● 51000.300.030	90,45	-	-	-	-	-	-
300	1,6	32	180 BW	2-8-45+2-9-50+2-11-63	● 51000.300.040	90,45	-	-	-	-	-	-
300	2,0	32	0	2-8-45+2-9-50+2-11-63	● 51000.300.050	79,35	-	-	● 51300.300.050	104,35	-	-
300	2,0	32	300 BW	2-8-45+2-9-50+2-11-63	● 51000.300.060	86,25	-	-	-	-	-	-
300	2,0	32	220 BW	2-8-45+2-9-50+2-11-63	● 51000.300.070	86,25	-	-	-	-	-	-
300	2,0	32	180 BW	2-8-45+2-9-50+2-11-63	● 51000.300.080	86,25	-	-	-	-	-	-
300	2,5	32	0	2-8-45+2-9-50+2-11-63	● 51000.300.090	80,40	-	-	● 51300.300.090	105,65	-	-
300	2,5	32	220 BW	2-8-45+2-9-50+2-11-63	● 51000.300.100	87,40	● 51040.300.100	128,85	● 51300.300.100	114,85	● 51340.300.100	149,70
300	2,5	32	200 BW	2-8-45+2-9-50+2-11-63	● 51000.300.110	87,40	● 51040.300.110	128,85	● 51300.300.110	114,85	● 51340.300.110	149,70
300	2,5	32	180 BW	2-8-45+2-9-50+2-11-63	● 51000.300.120	87,40	● 51040.300.120	128,85	● 51300.300.120	114,85	● 51340.300.120	149,70
300	2,5	32	160 HZ	2-8-45+2-9-50+2-11-63	● 51000.300.130	87,40	● 51040.300.130	128,85	● 51300.300.130	114,85	● 51340.300.130	149,70
300	2,5	32	120 HZ	2-8-45+2-9-50+2-11-63	● 51000.300.140	87,40	● 51040.300.140	128,85	● 51300.300.140	114,85	-	-
300	2,5	32	100 HZ	2-8-45+2-9-50+2-11-63	● 51000.300.150	87,40	-	-	▲ 51300.300.150	111,00	-	-
300	2,5	32	0	-	▲ 51000.300.160	80,75	-	-	▲ 51300.300.160	105,65	-	-
300	2,5	32	220 BW	-	▲ 51000.300.170	85,00	-	-	-	-	-	-
300	2,5	32	200 BW	-	▲ 51000.300.180	85,00	-	-	-	-	-	-
300	2,5	32	160 HZ	-	▲ 51000.300.190	85,00	-	-	-	-	-	-
300	2,5	32	120 HZ	-	▲ 51000.300.200	85,00	-	-	-	-	-	-
300	2,5	40	0	2-8-55 + 4-12-64	● 51000.300.210	80,40	-	-	● 51300.300.210	105,65	-	-
300	2,5	40	220 BW	2-8-55 + 4-12-64	● 51000.300.220	87,40	● 51040.300.220	128,85	● 51300.300.220	114,85	● 51340.300.220	149,70
300	2,5	40	200 BW	2-8-55 + 4-12-64	● 51000.300.230	87,40	● 51040.300.230	128,85	● 51300.300.230	114,85	● 51340.300.230	149,70
300	2,5	40	180 BW	2-8-55 + 4-12-64	● 51000.300.240	87,40	● 51040.300.240	128,85	● 51300.300.240	114,85	● 51340.300.240	149,70
300	2,5	40	160 HZ	2-8-55 + 4-12-64	● 51000.300.250	87,40	● 51040.300.250	128,85	● 51300.300.250	114,85	● 51340.300.250	149,70
300	2,5	40	120 HZ	2-8-55 + 4-12-64	● 51000.300.260	87,40	● 51040.300.260	128,85	● 51300.300.260	114,85	-	-
300	2,5	40	100 HZ	2-8-55 + 4-12-64	● 51000.300.270	87,40	▲ 51040.300.270	125,00	▲ 51300.300.270	111,00	-	-
300	3,0	32	0	2-8-45+2-9-50+2-11-63	▲ 51000.300.280	100,70	-	-	▲ 51300.300.280	126,35	-	-
300	3,0	32	160 HZ	2-8-45+2-9-50+2-11-63	-	-	-	-	▲ 51300.300.285	133,00	-	-
300	3,0	32	120 HZ	2-8-45+2-9-50+2-11-63	▲ 51000.300.290	106,00	-	-	-	-	-	-
300	3,0	32	0	-	▲ 51000.300.300	100,70	-	-	-	-	-	-
300	3,0	40	0	2-8-55 + 4-12-64	▲ 51000.300.310	100,70	-	-	▲ 51300.300.310	126,35	-	-
300	3,0	40	160 HZ	2-8-55 + 4-12-64	▲ 51000.300.320	106,00	-	-	-	-	-	-
300	3,0	40	120 HZ	2-8-55 + 4-12-64	▲ 51000.300.330	106,00	-	-	-	-	-	-
315	1,6	32	0	2-8-45+2-9-50+2-11-63	● 51000.315.010	95,35	-	-	● 51300.315.010	116,65	-	-
315	1,6	32	300 BW	2-8-45+2-9-50+2-11-63	● 51000.315.020	103,65	-	-	-	-	-	-
315	1,6	32	240 BW	2-8-45+2-9-50+2-11-63	● 51000.315.030	103,65	-	-	-	-	-	-
315	1,6	32	220 BW	2-8-45+2-9-50+2-11-63	● 51000.315.040	103,65	-	-	-	-	-	-
315	1,6	32	200 BW	2-8-45+2-9-50+2-11-63	● 51000.315.050	103,65	-	-	-	-	-	-
315	1,6	40	0	2-8-55 + 4-12-64	● 51000.315.060	95,35	-	-	● 51300.315.060	116,65	-	-
315	1,6	40	300 BW	2-8-55 + 4-12-64	● 51000.315.070	103,65	-	-	-	-	-	-
315	1,6	40	240 BW	2-8-55 + 4-12-64	● 51000.315.080	103,65	-	-	-	-	-	-
315	1,6	40	220 BW	2-8-55 + 4-12-64	● 51000.315.090	103,65	-	-	-	-	-	-
315	1,6	40	200 BW	2-8-55 + 4-12-64	● 51000.315.100	103,65	-	-	-	-	-	-
315	2,0	32	0	2-8-45+2-9-50+2-11-63	● 51000.315.110	85,55	-	-	● 51300.315.110	111,80	-	-

Weitere Abmessungen auf Anfrage · Other dimensions are available on request

Anwendung siehe Seite
Application see page

					680	681	682	683				
					Art. 5.1000 HSS-DMo5 Dampfbehandelt Steam treated	Art. 5.1040 HSS-DMo5 Kx-Beschichtet Kx-coated	Art. 5.1300 HSS-Co5 Dampfbehandelt Steam treated	Art. 5.1340 HSS-Co5 Kx-Beschichtet Kx-coated				
					Art.	€	Art.	€	Art.	€	Art.	€
315	2,0	32	300 BW	2-8-45+2-9-50+2-11-63	● 51000.315.120	93,00	-	-	-	-	-	-
315	2,0	32	240 BW	2-8-45+2-9-50+2-11-63	● 51000.315.130	93,00	-	-	-	-	-	-
315	2,0	32	220 BW	2-8-45+2-9-50+2-11-63	● 51000.315.140	93,00	-	-	-	-	-	-
315	2,0	32	200 BW	2-8-45+2-9-50+2-11-63	● 51000.315.150	93,00	-	-	-	-	-	-
315	2,0	32	180 BW	2-8-45+2-9-50+2-11-63	● 51000.315.160	93,00	-	-	-	-	-	-
315	2,0	40	0	2-8-55 + 4-12-64	● 51000.315.170	85,55	-	-	● 51300.315.170	111,80	-	-
315	2,0	40	300 BW	2-8-55 + 4-12-64	● 51000.315.180	93,00	-	-	-	-	-	-
315	2,0	40	240 BW	2-8-55 + 4-12-64	● 51000.315.190	93,00	-	-	-	-	-	-
315	2,0	40	220 BW	2-8-55 + 4-12-64	● 51000.315.200	93,00	-	-	-	-	-	-
315	2,0	40	200 BW	2-8-55 + 4-12-64	● 51000.315.210	93,00	-	-	-	-	-	-
315	2,0	40	180 BW	2-8-55 + 4-12-64	● 51000.315.220	93,00	-	-	-	-	-	-
315	2,5	32	0	2-8-45+2-9-50+2-11-63	● 51000.315.230	86,85	-	-	● 51300.315.230	114,90	-	-
315	2,5	32	240 BW	2-8-45+2-9-50+2-11-63	● 51000.315.240	94,40	● 51040.315.240	140,05	● 51300.315.240	124,90	● 51340.315.240	164,75
315	2,5	32	220 BW	2-8-45+2-9-50+2-11-63	● 51000.315.250	94,40	● 51040.315.250	140,05	● 51300.315.250	124,90	● 51340.315.250	164,75
315	2,5	32	200 BW	2-8-45+2-9-50+2-11-63	● 51000.315.260	94,40	● 51040.315.260	140,05	● 51300.315.260	124,90	● 51340.315.260	164,75
315	2,5	32	180 BW	2-8-45+2-9-50+2-11-63	● 51000.315.270	94,40	● 51040.315.270	140,05	● 51300.315.270	124,90	● 51340.315.270	164,75
315	2,5	32	160 HZ	2-8-45+2-9-50+2-11-63	● 51000.315.280	94,40	● 51040.315.280	140,05	● 51300.315.280	124,90	● 51340.315.280	164,75
315	2,5	32	120 HZ	2-8-45+2-9-50+2-11-63	● 51000.315.290	94,40	● 51040.315.290	140,05	● 51300.315.290	124,90	● 51340.315.290	164,75
315	2,5	32	100 HZ	2-8-45+2-9-50+2-11-63	-	-	▲ 51040.315.295	134,00	-	-	-	-
315	2,5	40	0	2-8-55 + 4-12-64	● 51000.315.300	86,85	-	-	● 51300.315.300	124,90	-	-
315	2,5	40	240 BW	2-8-55 + 4-12-64	● 51000.315.310	94,40	● 51040.315.310	140,05	● 51300.315.310	124,90	● 51340.315.310	164,75
315	2,5	40	220 BW	2-8-55 + 4-12-64	● 51000.315.320	94,40	● 51040.315.320	140,05	● 51300.315.320	124,90	● 51340.315.320	164,75
315	2,5	40	200 BW	2-8-55 + 4-12-64	● 51000.315.330	94,40	● 51040.315.330	140,05	● 51300.315.330	124,90	● 51340.315.330	164,75
315	2,5	40	180 BW	2-8-55 + 4-12-64	● 51000.315.340	94,40	● 51040.315.340	140,05	● 51300.315.340	124,90	● 51340.315.340	164,75
315	2,5	40	160 HZ	2-8-55 + 4-12-64	● 51000.315.350	94,40	● 51040.315.350	140,05	● 51300.315.350	124,90	● 51340.315.350	164,75
315	2,5	40	120 HZ	2-8-55 + 4-12-64	● 51000.315.360	94,40	● 51040.315.360	140,05	● 51300.315.360	124,90	-	-
315	2,5	40	100 HZ	2-8-55 + 4-12-64	▲ 51000.315.370	91,00	▲ 51040.315.370	134,00	-	-	-	-
315	2,5	50	0	4-15-80 + 4-14-85	▲ 51000.315.380	86,45	-	-	▲ 51300.315.380	114,95	-	-
315	2,5	50	240 BW	4-15-80 + 4-14-85	▲ 51000.315.390	91,00	-	-	-	-	-	-
315	2,5	50	160 HZ	4-15-80 + 4-14-85	▲ 51000.315.400	91,00	-	-	-	-	-	-
315	2,5	50	120 HZ	4-15-80 + 4-14-85	▲ 51000.315.410	91,00	-	-	-	-	-	-
315	3,0	32	0	2-8-45+2-9-50+2-11-63	● 51000.315.420	108,20	-	-	● 51300.315.420	128,85	-	-
315	3,0	32	240 BW	2-8-45+2-9-50+2-11-63	● 51000.315.430	117,65	● 51040.315.430	151,25	● 51300.315.430	140,05	-	-
315	3,0	32	200 BW	2-8-45+2-9-50+2-11-63	● 51000.315.440	117,65	● 51040.315.440	151,25	● 51300.315.440	140,05	-	-
315	3,0	32	160 HZ	2-8-45+2-9-50+2-11-63	● 51000.315.450	117,65	● 51040.315.450	151,25	● 51300.315.450	140,05	-	-
315	3,0	32	120 HZ	2-8-45+2-9-50+2-11-63	-	-	▲ 51040.315.455	146,00	▲ 51300.315.455	135,00	-	-
315	3,0	32	100 HZ	2-8-45+2-9-50+2-11-63	-	-	▲ 51040.315.457	146,00	▲ 51300.315.457	135,00	-	-
315	3,0	40	0	2-8-55 + 4-12-64	● 51000.315.460	108,20	-	-	● 51300.315.460	128,85	-	-
315	3,0	40	240 BW	2-8-55 + 4-12-64	● 51000.315.470	117,65	● 51040.315.470	151,25	● 51300.315.470	140,05	-	-
315	3,0	40	200 BW	2-8-55 + 4-12-64	● 51000.315.480	117,65	● 51040.315.480	151,25	● 51300.315.480	140,05	-	-
315	3,0	40	160 HZ	2-8-55 + 4-12-64	● 51000.315.490	117,65	● 51040.315.490	151,25	● 51300.315.490	140,05	-	-
315	3,0	40	120 HZ	2-8-55 + 4-12-64	▲ 51000.315.500	114,00	▲ 51040.315.500	146,00	▲ 51300.315.500	135,00	-	-
315	3,0	40	100 HZ	2-8-55 + 4-12-64	▲ 51000.315.510	114,00	▲ 51040.315.510	146,00	▲ 51300.315.510	135,00	-	-
315	3,0	50	0	4-15-80 + 4-14-85	▲ 51000.315.520	108,30	-	-	▲ 51300.315.520	128,25	-	-
315	3,0	50	160 HZ	4-15-80 + 4-14-85	▲ 51000.315.530	114,00	-	-	-	-	-	-
315	3,0	50	120 HZ	4-15-80 + 4-14-85	▲ 51000.315.540	114,00	-	-	-	-	-	-
325	2,5	40	0	2-8-55 + 4-12-64	● 51000.325.010	110,00	-	-	● 51300.325.010	120,30	-	-
325	2,5	40	160 HZ	2-8-55 + 4-12-64	● 51000.325.020	117,90	-	-	● 51300.325.020	130,80	-	-
325	3,0	40	0	2-9-55 + 4-12-64	▲ 51000.325.030	114,95	-	-	▲ 51300.325.030	140,60	-	-
325	3,0	40	160 HZ	2-9-55 + 4-12-64	-	-	-	-	▲ 51300.325.040	148,00	-	-
350	2,0	32	0	2-8-45+2-9-50+2-11-63	● 51000.350.010	109,75	-	-	● 51300.350.010	139,15	-	-
350	2,0	32	350 BW	2-8-45+2-9-50+2-11-63	● 51000.350.020	119,30	● 51040.350.020	162,15	● 51300.350.020	150,65	● 51340.350.020	190,00
350	2,0	32	280 BW	2-8-45+2-9-50+2-11-63	● 51000.350.030	119,30	● 51040.350.030	162,15	● 51300.350.030	150,65	● 51340.350.030	190,00
350	2,0	32	240 BW	2-8-45+2-9-50+2-11-63	● 51000.350.040	119,30	● 51040.350.040	162,15	● 51300.350.040	150,65	● 51340.350.040	190,00
350	2,0	32	220 BW	2-8-45+2-9-50+2-11-63	● 51000.350.050	119,30	● 51040.350.050	162,15	● 51300.350.050	150,65	● 51340.350.050	190,00
350	2,5	32	0	2-8-45+2-9-50+2-11-63	● 51000.350.060	108,45	-	-	● 51300.350.060	139,15	-	-
350	2,5	32	350 BW	2-8-45+2-9-50+2-11-63	● 51000.350.070	117,90	● 51040.350.070	162,15	● 51300.350.070	151,25	● 51340.350.070	192,80

Weitere Abmessungen auf Anfrage · Other dimensions are available on request



Art.
100
101
102

Karnasch® METALLKREISSÄGEBLÄTTER METAL CIRCULAR SAW BLADES

Anwendung siehe Seite
Application see page

680



681



682



683



					Art. 5.1000		Art. 5.1040		Art. 5.1300		Art. 5.1340		
					HSS-DMo5 Dampfbehandelt Steam treated		HSS-DMo5 Kx-Beschichtet Kx-coated		HSS-Co5 Dampfbehandelt Steam treated		HSS-Co5 Kx-Beschichtet Kx-coated		
					Art.	€	Art.	€	Art.	€	Art.	€	
1		32	BW	280 BW	2-8-45+2-9-50+2-11-63	● 51000.350.080	117,90	● 51040.350.080	162,15	● 51300.350.080	151,25	● 51340.350.080	192,80
			HZ	240 BW	2-8-45+2-9-50+2-11-63	● 51000.350.090	117,90	● 51040.350.090	162,15	● 51300.350.090	151,25	● 51340.350.090	192,80
2		32	BW	220 BW	2-8-45+2-9-50+2-11-63	● 51000.350.100	117,90	● 51040.350.100	162,15	● 51300.350.100	151,25	● 51340.350.100	192,80
			HZ	180 HZ	2-8-45+2-9-50+2-11-63	● 51000.350.110	117,90	● 51040.350.110	162,15	● 51300.350.110	151,25	● 51340.350.110	192,80
3		32	BW	160 HZ	2-8-45+2-9-50+2-11-63	● 51000.350.120	117,90	● 51040.350.120	162,15	● 51300.350.120	151,25	● 51340.350.120	192,80
			HZ	140 HZ	2-8-45+2-9-50+2-11-63	● 51000.350.130	117,90	▲ 51040.350.130	157,00	▲ 51300.350.130	146,00	-	-
4		32	BW	120 HZ	2-8-45+2-9-50+2-11-63	● 51000.350.140	117,90	▲ 51040.350.140	157,00	▲ 51300.350.140	146,00	-	-
			HZ	0	2-8-55+4-12-64	● 51000.350.150	108,45	-	-	● 51300.350.150	139,15	-	-
5		40	BW	350 BW	2-8-55+4-12-64	● 51000.350.160	117,90	● 51040.350.160	162,15	● 51300.350.160	151,25	● 51340.350.160	192,80
			HZ	280 BW	2-8-55+4-12-64	● 51000.350.170	117,90	● 51040.350.170	162,15	● 51300.350.170	151,25	● 51340.350.170	192,80
6		40	BW	240 BW	2-8-55+4-12-64	● 51000.350.180	117,90	● 51040.350.180	162,15	● 51300.350.180	151,25	● 51340.350.180	192,80
			HZ	220 BW	2-8-55+4-12-64	● 51000.350.190	117,90	● 51040.350.190	162,15	● 51300.350.190	151,25	● 51340.350.190	192,80
7		40	BW	180 HZ	2-8-55+4-12-64	● 51000.350.200	117,90	● 51040.350.200	162,15	● 51300.350.200	151,25	● 51340.350.200	192,80
			HZ	160 HZ	2-8-55+4-12-64	● 51000.350.205	117,90	● 51040.350.205	162,15	● 51300.350.205	151,25	● 51340.350.205	192,80
8		40	BW	120 HZ	2-8-55 + 4-12-64	-	-	▲ 51040.350.207	157,00	-	-	-	-
			HZ	0	4-15-80 + 4-14-85	▲ 51000.350.210	102,60	-	-	▲ 51300.350.210	138,70	-	-
9		50	BW	220 BW	4-15-80 + 4-14-85	▲ 51000.350.220	108,00	▲ 51040.350.220	157,00	-	-	-	-
			HZ	160 HZ	4-15-80 + 4-14-85	▲ 51000.350.230	108,00	-	-	▲ 51300.350.230	146,00	-	-
10		50	BW	120 HZ	4-15-80 + 4-14-85	▲ 51000.350.240	108,00	▲ 51040.350.240	157,00	-	-	-	-
			HZ	100 HZ	4-15-80 + 4-14-85	▲ 51000.350.250	108,00	▲ 51040.350.250	157,00	-	-	-	-
11		32	BW	0	2-8-45+2-9-50+2-11-63	● 51000.350.260	123,70	-	-	● 51300.350.260	151,25	-	-
			HZ	280 BW	2-8-45+2-9-50+2-11-63	● 51000.350.270	134,45	● 51040.350.270	177,85	● 51300.350.270	168,05	● 51340.350.270	208,75
12		32	BW	240 BW	2-8-45+2-9-50+2-11-63	● 51000.350.280	134,45	● 51040.350.280	177,85	● 51300.350.280	168,05	● 51340.350.280	208,75
			HZ	220 BW	2-8-45+2-9-50+2-11-63	● 51000.350.290	134,45	● 51040.350.290	177,85	● 51300.350.290	168,05	● 51340.350.290	208,75
13		32	BW	200 BW	2-8-45+2-9-50+2-11-63	● 51000.350.300	134,45	● 51040.350.300	177,85	● 51300.350.300	168,05	● 51340.350.300	208,75
			HZ	180 HZ	2-8-45+2-9-50+2-11-63	● 51000.350.310	134,45	● 51040.350.310	177,85	● 51300.350.310	168,05	● 51340.350.310	208,75
14		32	BW	160 HZ	2-8-45+2-9-50+2-11-63	● 51000.350.320	134,45	● 51040.350.320	177,85	● 51300.350.320	168,05	● 51340.350.320	208,75
			HZ	140 HZ	2-8-45+2-9-50+2-11-63	● 51000.350.330	134,45	● 51040.350.330	177,85	● 51300.350.330	168,05	-	-
15		32	BW	120 HZ	2-8-45+2-9-50+2-11-63	● 51000.350.340	134,45	● 51040.350.340	177,85	● 51300.350.340	168,05	-	-
			HZ	0	2-8-55+4-12-64	● 51000.350.350	123,70	-	-	● 51300.350.350	154,60	-	-
16		40	BW	280 BW	2-8-55+4-12-64	● 51000.350.360	134,45	● 51040.350.360	177,85	● 51300.350.360	168,05	● 51340.350.360	208,75
			HZ	240 BW	2-8-55+4-12-64	● 51000.350.370	134,45	● 51040.350.370	177,85	● 51300.350.370	168,05	● 51340.350.370	208,75
17		40	BW	220 BW	2-8-55+4-12-64	● 51000.350.380	134,45	● 51040.350.380	177,85	● 51300.350.380	168,05	● 51340.350.380	208,75
			HZ	200 BW	2-8-55+4-12-64	● 51000.350.390	134,45	● 51040.350.390	177,85	● 51300.350.390	168,05	● 51340.350.390	208,75
18		40	BW	180 HZ	2-8-55+4-12-64	● 51000.350.400	134,45	● 51040.350.400	177,85	● 51300.350.400	168,05	● 51340.350.400	208,75
			HZ	160 HZ	2-8-55+4-12-64	● 51000.350.410	134,45	● 51040.350.410	177,85	● 51300.350.410	168,05	● 51340.350.410	208,75
19		40	BW	140 HZ	2-8-55+4-12-64	● 51000.350.420	134,45	● 51040.350.420	177,85	● 51300.350.420	168,05	● 51340.350.420	208,75
			HZ	120 HZ	2-8-55+4-12-64	● 51000.350.430	134,45	● 51040.350.430	177,85	● 51300.350.430	168,05	-	-
20		40	BW	110 HZ	2-8-55+4-12-64	● 51000.350.440	134,45	● 51040.350.440	177,85	● 51300.350.440	168,05	-	-
			HZ	90 HZ	2-8-55+4-12-64	● 51000.350.450	134,45	● 51040.350.450	177,85	● 51300.350.450	168,05	-	-
21		50	BW	0	4-15-80 + 4-14-85	● 51000.350.460	123,70	-	-	● 51300.350.460	154,60	-	-
			HZ	220 BW	4-15-80 + 4-14-85	● 51000.350.470	134,45	▲ 51040.350.470	172,00	● 51300.350.470	168,05	-	-
22		50	BW	180 HZ	4-15-80 + 4-14-85	● 51000.350.480	134,45	-	-	● 51300.350.480	168,05	-	-
			HZ	160 HZ	4-15-80 + 4-14-85	● 51000.350.490	134,45	▲ 51040.350.490	172,00	● 51300.350.490	168,05	-	-
23		50	BW	140 HZ	4-15-80 + 4-14-85	● 51000.350.500	134,45	-	-	● 51300.350.500	168,05	-	-
			HZ	120 HZ	4-15-80 + 4-14-85	● 51000.350.510	134,45	▲ 51040.350.510	172,00	● 51300.350.510	168,05	-	-
24		50	BW	100 HZ	4-15-80 + 4-14-85	▲ 51000.350.520	130,00	▲ 51040.350.520	172,00	-	-	-	-
			HZ	0	4-15-80 + 4-14-85	▲ 51000.360.010	149,15	-	-	-	-	-	-
25		50	BW	120 HZ	4-15-80 + 4-14-85	▲ 51000.360.030	157,00	-	-	-	-	-	-
			HZ	0	2-8-45+2-9-50+2-11-63	● 51000.370.010	149,70	-	-	● 51300.370.010	196,05	-	-
26		32	BW	220 BW	2-8-45+2-9-50+2-11-63	● 51000.370.020	162,70	-	-	-	-	-	-
			HZ	160 HZ	2-8-45+2-9-50+2-11-63	● 51000.370.030	162,70	-	-	-	-	-	-
27		32	BW	120 HZ	2-8-45+2-9-50+2-11-63	● 51000.370.040	162,70	-	-	-	-	-	-
			HZ	0	2-8-55+4-12-64	● 51000.370.050	149,70	-	-	● 51300.370.050	196,05	-	-
28		40	BW	220 BW	2-8-55+4-12-64	● 51000.370.060	162,70	-	-	-	-	-	-
			HZ	160 HZ	2-8-55+4-12-64	● 51000.370.070	162,70	-	-	-	-	-	-
29		40	BW	120 HZ	2-8-55+4-12-64	● 51000.370.080	162,70	-	-	-	-	-	-
			HZ	0	2-8-55+4-12-64	-	-	-	-	-	-	-	-

Weitere Abmessungen auf Anfrage · Other dimensions are available on request

Anwendung siehe Seite
Application see page

					680	681	682	683				
					Art. 5.1000 HSS-DMo5 Dampfbehandelt Steam treated	Art. 5.1040 HSS-DMo5 Kx-Beschichtet Kx-coated	Art. 5.1300 HSS-Co5 Dampfbehandelt Steam treated	Art. 5.1340 HSS-Co5 Kx-Beschichtet Kx-coated				
					Art.	€	Art.	€	Art.	€	Art.	€
370	2,5	50	0	4-15-80 + 4-14-85	● 51000.370.090	149,70	-	-	● 51300.370.090	196,05	-	-
370	2,5	50	220 BW	4-15-80 + 4-14-85	● 51000.370.100	162,70	-	-	-	-	-	-
370	2,5	50	160 HZ	4-15-80 + 4-14-85	● 51000.370.110	162,70	-	-	-	-	-	-
370	2,5	50	120 HZ	4-15-80 + 4-14-85	● 51000.370.120	162,70	-	-	-	-	-	-
370	3,0	40	0	2-8-55+4-12-64	● 51000.370.130	158,20	-	-	● 51300.370.130	206,10	-	-
370	3,0	40	220 BW	2-8-55+4-12-64	● 51000.370.140	171,90	-	-	-	-	-	-
370	3,0	40	160 HZ	2-8-55+4-12-64	● 51000.370.150	171,90	-	-	▲ 51300.370.150	162,00	-	-
370	3,0	40	120 HZ	2-8-55+4-12-64	● 51000.370.160	171,90	-	-	▲ 51300.370.160	162,00	-	-
370	3,0	50	0	4-15-80 + 4-14-85	● 51000.370.170	158,15	-	-	● 51300.370.170	206,10	-	-
370	3,0	50	220 BW	4-15-80 + 4-14-85	● 51000.370.180	171,90	● 51040.370.180	216,40	● 51300.370.180	219,45	-	-
370	3,0	50	160 HZ	4-15-80 + 4-14-85	● 51000.370.190	171,90	● 51040.370.190	216,40	● 51300.370.190	219,45	-	-
370	3,0	50	120 HZ	4-15-80 + 4-14-85	● 51000.370.200	171,90	● 51040.370.200	216,40	● 51300.370.200	219,45	-	-
370	3,0	50	100 HZ	4-15-80 + 4-14-85	● 51000.370.210	171,90	● 51040.370.210	216,40	● 51300.370.210	219,45	-	-
400	2,5	32	0	2-8-45+2-9-50+2-11-63	● 51000.400.010	177,75	-	-	● 51300.400.010	239,60	-	-
400	2,5	32	240 BW	2-8-45+2-9-50+2-11-63	● 51000.400.020	193,25	-	-	-	-	-	-
400	2,5	32	200 HZ	2-8-45+2-9-50+2-11-63	● 51000.400.030	193,25	-	-	-	-	-	-
400	2,5	32	160 HZ	2-8-45+2-9-50+2-11-63	● 51000.400.040	193,25	-	-	-	-	-	-
400	2,5	50	0	4-15-80+4-14-85	● 51000.400.050	177,75	-	-	● 51300.400.050	239,60	-	-
400	2,5	50	240 BW	4-15-80+4-14-85	● 51000.400.060	193,25	-	-	-	-	-	-
400	2,5	50	200 HZ	4-15-80+4-14-85	● 51000.400.070	193,25	-	-	-	-	-	-
400	2,5	50	160 HZ	4-15-80+4-14-85	● 51000.400.080	193,25	-	-	-	-	-	-
400	3,0	32	0	2-8-45+2-9-50+2-11-63	● 51000.400.090	172,60	-	-	● 51300.400.090	229,30	-	-
400	3,0	32	200 HZ	2-8-45+2-9-50+2-11-63	● 51000.400.100	187,65	-	-	-	-	-	-
400	3,0	32	160 HZ	2-8-45+2-9-50+2-11-63	● 51000.400.110	187,65	-	-	-	-	-	-
400	3,0	32	120 HZ	2-8-45+2-9-50+2-11-63	● 51000.400.120	187,65	-	-	-	-	-	-
400	3,0	32	100 HZ	2-8-45+2-9-50+2-11-63	● 51000.400.130	187,65	-	-	-	-	-	-
400	3,0	40	0	2-8-55+4-12-64	● 51000.400.140	179,45	-	-	● 51300.400.140	229,30	-	-
400	3,0	40	200 HZ	2-8-55+4-12-64	● 51000.400.150	187,65	-	-	● 51300.400.150	249,25	-	-
400	3,0	40	160 HZ	2-8-55+4-12-64	● 51000.400.160	187,65	-	-	● 51300.400.160	249,25	-	-
400	3,0	40	120 HZ	2-8-55+4-12-64	● 51000.400.170	187,65	-	-	● 51300.400.170	249,25	-	-
400	3,0	40	100 HZ	2-8-55+4-12-64	● 51000.400.180	187,65	-	-	● 51300.400.180	249,25	-	-
400	3,0	50	0	4-15-80+4-14-85	● 51000.400.190	172,60	-	-	● 51300.400.190	229,30	-	-
400	3,0	50	200 HZ	4-15-80+4-14-85	● 51000.400.200	187,65	-	-	● 51300.400.200	249,25	-	-
400	3,0	50	160 HZ	4-15-80+4-14-85	● 51000.400.210	187,65	-	-	● 51300.400.210	249,25	-	-
400	3,0	50	120 HZ	4-15-80+4-14-85	● 51000.400.220	187,65	-	-	● 51300.400.220	249,25	-	-
400	3,0	50	100 HZ	4-15-80+4-14-85	● 51000.400.230	187,65	-	-	● 51300.400.230	249,25	-	-
400	3,5	40	0	2-15-80 + 4-12-64	▲ 51000.400.240	190,00	-	-	▲ 51300.400.240	248,90	-	-
400	3,5	40	160 HZ	2-15-80 + 4-12-64	▲ 51000.400.250	200,00	-	-	-	-	-	-
400	3,5	40	120 HZ	2-15-80 + 4-12-64	▲ 51000.400.260	200,00	-	-	-	-	-	-
400	3,5	50	0	4-15-80+4-14-85	● 51000.400.270	190,65	-	-	● 51300.400.270	249,90	-	-
400	3,5	50	200 HZ	4-15-80+4-14-85	● 51000.400.280	207,25	-	-	● 51300.400.280	271,65	-	-
400	3,5	50	160 HZ	4-15-80+4-14-85	● 51000.400.290	207,25	-	-	● 51300.400.290	271,65	-	-
400	3,5	50	120 HZ	4-15-80+4-14-85	● 51000.400.300	207,25	-	-	● 51300.400.300	271,65	-	-
400	3,5	50	100 HZ	4-15-80+4-14-85	● 51000.400.310	207,25	-	-	● 51300.400.310	271,65	-	-
400	4,0	40	0	2-15-80 + 4-12-64	▲ 51000.400.320	215,65	-	-	▲ 51300.400.320	272,65	-	-
400	4,0	40	200 HZ	2-15-80 + 4-12-64	▲ 51000.400.330	227,00	-	-	-	-	-	-
400	4,0	40	120 HZ	2-15-80 + 4-12-64	▲ 51000.400.340	227,00	-	-	-	-	-	-
400	4,0	40	100 HZ	2-15-80 + 4-12-64	▲ 51000.400.350	227,00	-	-	-	-	-	-
400	4,0	50	0	4-15-80+4-14-85	● 51000.400.360	216,40	-	-	● 51300.400.360	273,10	-	-
400	4,0	50	200 HZ	4-15-80+4-14-85	● 51000.400.370	235,25	-	-	● 51300.400.370	287,00	-	-
400	4,0	50	160 HZ	4-15-80+4-14-85	● 51000.400.380	235,25	-	-	● 51300.400.380	296,85	-	-
400	4,0	50	120 HZ	4-15-80+4-14-85	● 51000.400.390	235,25	-	-	● 51300.400.390	296,85	-	-
400	4,0	50	100 HZ	4-15-80+4-14-85	● 51000.400.400	235,25	-	-	● 51300.400.400	296,85	-	-
425	3,0	40	0	2-15-80 + 2-15-100 + 4-12-64	▲ 51000.425.010	195,70	-	-	-	-	-	-
425	3,0	40	160 HZ	2-15-80 + 2-15-100 + 4-12-64	▲ 51000.425.020	206,00	-	-	-	-	-	-
425	3,0	40	120 HZ	2-15-80 + 2-15-100 + 4-12-64	▲ 51000.425.030	206,00	-	-	-	-	-	-
425	3,0	50	0	4-15-80+4-14-85	● 51000.425.040	195,80	-	-	● 51300.425.040	267,55	-	-

Weitere Abmessungen auf Anfrage · Other dimensions are available on request



Art.
100
101
102

Anwendung siehe Seite
Application see page

680



681



682



683



Art.	€	Art. 5.1000		Art. 5.1040		Art. 5.1300		Art. 5.1340		
		Art.	€	Art.	€	Art.	€	Art.	€	
425	3,0	50	220 HZ	4-15-80+4-14-85	● 51000.425.050	212,85	-	-	-	-
425	3,0	50	160 HZ	4-15-80+4-14-85	● 51000.425.060	212,85	-	-	-	-
425	3,0	50	120 HZ	4-15-80+4-14-85	▲ 51000.425.070	206,00	-	-	-	-
425	3,5	40	0	2-15-80 + 2-15-100 + 4-12-64	● 51000.425.080	224,15	-	-	● 51300.425.080	311,75
425	3,5	40	220 HZ	2-15-80 + 2-15-100 + 4-12-64	● 51000.425.090	243,65	-	-	-	-
425	3,5	40	160 HZ	2-15-80 + 2-15-100 + 4-12-64	● 51000.425.100	243,65	-	-	-	-
425	3,5	50	0	4-15-80+4-14-85	● 51000.425.110	224,15	-	-	● 51300.425.110	311,75
425	3,5	50	220 HZ	4-15-80+4-14-85	● 51000.425.120	243,65	-	-	-	-
425	3,5	50	160 HZ	4-15-80+4-14-85	● 51000.425.130	243,65	-	-	-	-
425	3,5	50	120 HZ	4-15-80+4-14-85	▲ 51000.425.140	235,00	-	-	-	-
425	4,0	40	0	2-15-80 + 2-15-100 + 4-12-64	▲ 51000.425.150	244,15	-	-	▲ 51300.425.150	333,45
425	4,0	40	220 HZ	2-15-80 + 2-15-100 + 4-12-64	▲ 51000.425.160	257,00	-	-	-	-
425	4,0	40	160 HZ	2-15-80 + 2-15-100 + 4-12-64	▲ 51000.425.170	257,00	-	-	▲ 51300.425.170	351,00
425	4,0	40	120 HZ	2-15-80 + 2-15-100 + 4-12-64	▲ 51000.425.180	257,00	-	-	-	-
425	4,0	50	0	4-15-80+4-14-85	● 51000.425.190	242,15	-	-	● 51300.425.190	334,90
425	4,0	50	76 HZ	4-15-80+4-14-85	▲ 51000.425.200	257,00	-	-	-	-
450	3,0	40	0	2-15-80 + 2-15-100 + 4-12-64	● 51000.450.010	219,00	-	-	● 51300.450.010	303,70
450	3,0	40	240 HZ	2-15-80 + 2-15-100 + 4-12-64	● 51000.450.020	238,05	-	-	-	-
450	3,0	40	200 HZ	2-15-80 + 2-15-100 + 4-12-64	● 51000.450.030	238,05	-	-	-	-
450	3,0	40	180 HZ	2-15-80 + 2-15-100 + 4-12-64	● 51000.450.040	238,05	-	-	-	-
450	3,0	40	160 HZ	2-15-80 + 2-15-100 + 4-12-64	● 51000.450.050	238,05	-	-	-	-
450	3,0	40	120 HZ	2-15-80 + 2-15-100 + 4-12-64	● 51000.450.060	238,05	-	-	-	-
450	3,0	50	0	4-15-80+4-14-85	● 51000.450.070	219,00	-	-	● 51300.450.070	303,70
450	3,0	50	240 HZ	4-15-80+4-14-85	● 51000.450.080	238,05	-	-	-	-
450	3,0	50	200 HZ	4-15-80+4-14-85	● 51000.450.090	238,05	-	-	-	-
450	3,0	50	180 HZ	4-15-80+4-14-85	● 51000.450.100	238,05	-	-	-	-
450	3,0	50	160 HZ	4-15-80+4-14-85	● 51000.450.110	238,05	-	-	-	-
450	3,0	50	120 HZ	4-15-80+4-14-85	● 51000.450.120	238,05	-	-	-	-
450	3,5	40	0	2-15-80 + 2-15-100 + 4-12-64	● 51000.450.130	234,45	-	-	● 51300.450.130	334,90
450	3,5	40	240 HZ	2-15-80 + 2-15-100 + 4-12-64	● 51000.450.140	254,85	-	-	▲ 51300.450.140	338,00
450	3,5	40	200 HZ	2-15-80 + 2-15-100 + 4-12-64	● 51000.450.150	254,85	-	-	-	-
450	3,5	40	180 HZ	2-15-80 + 2-15-100 + 4-12-64	● 51000.450.160	254,85	-	-	-	-
450	3,5	40	160 HZ	2-15-80 + 2-15-100 + 4-12-64	● 51000.450.170	254,85	-	-	-	-
450	3,5	40	120 HZ	2-15-80 + 2-15-100 + 4-12-64	● 51000.450.180	254,85	-	-	▲ 51300.450.180	338,00
450	3,5	50	0	4-15-80+4-14-85	● 51000.450.190	234,45	-	-	● 51300.450.190	334,90
450	3,5	50	240 HZ	4-15-80+4-14-85	● 51000.450.200	254,85	-	-	▲ 51300.450.200	338,00
450	3,5	50	200 HZ	4-15-80+4-14-85	● 51000.450.210	254,85	-	-	-	-
450	3,5	50	180 HZ	4-15-80+4-14-85	● 51000.450.220	254,85	-	-	▲ 51300.450.220	338,00
450	3,5	50	160 HZ	4-15-80+4-14-85	● 51000.450.230	254,85	-	-	-	-
450	3,5	50	120 HZ	4-15-80+4-14-85	● 51000.450.240	254,85	-	-	-	-
450	4,0	40	0	2-15-80 + 2-15-100 + 4-12-64	● 51000.450.250	270,50	-	-	● 51300.450.250	380,95
450	4,0	40	240 HZ	2-15-80 + 2-15-100 + 4-12-64	● 51000.450.260	294,05	-	-	-	-
450	4,0	40	200 HZ	2-15-80 + 2-15-100 + 4-12-64	● 51000.450.270	294,05	-	-	-	-
450	4,0	40	180 HZ	2-15-80 + 2-15-100 + 4-12-64	● 51000.450.280	294,05	-	-	-	-
450	4,0	40	160 HZ	2-15-80 + 2-15-100 + 4-12-64	● 51000.450.290	294,05	-	-	-	-
450	4,0	40	120 HZ	2-15-80 + 2-15-100 + 4-12-64	● 51000.450.300	294,05	-	-	▲ 51300.450.300	384,00
450	4,0	50	0	4-15-80+4-14-85	● 51000.450.310	270,50	-	-	● 51300.450.310	380,95
450	4,0	50	240 HZ	4-15-80+4-14-85	● 51000.450.320	294,05	-	-	-	-
450	4,0	50	180 HZ	4-15-80+4-14-85	● 51000.450.330	294,05	-	-	-	-
450	4,0	50	120 HZ	4-15-80+4-14-85	● 51000.450.340	294,05	-	-	▲ 51300.450.340	384,00
500	4,0	40	0	2-15-80 + 2-15-100 + 4-12-64	▲ 51000.500.010	384,75	-	-	▲ 51300.500.010	449,35
500	4,0	40	260 HZ	2-15-80 + 2-15-100 + 4-12-64	▲ 51000.500.020	405,00	-	-	-	-
500	4,0	40	160 HZ	2-15-80 + 2-15-100 + 4-12-64	▲ 51000.500.030	405,00	-	-	-	-

Weitere Abmessungen auf Anfrage · Other dimensions are available on request

METALLKREISSÄGEBLÄTTER NACH DIN

Ausführung: blank geschliffen, Spanwinkel nach DIN 1840, Typ N

METAL CIRCULAR SAW BLADES, ACCORDING TO DIN

Version: Bright, cutting angle to DIN 1840, type N

Passende Aufnahmehalter / Fräsdorne siehe Seite 708
Suitable saw blade retainer / milling arbors see page 708



1



2



3



4



5



6



7



8



9



10



Art.
100
101
102



Art. **5.5000**

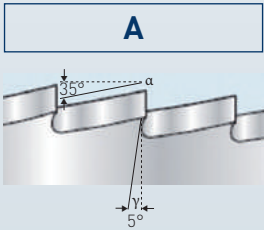

DIN 1837A Blätter kommen mit feingezahnten Winkelzähnen.

Hauptanwendungsgebiet:

- Feine Schlitz- und Trennarbeiten (Feinmechanik, Schmuckindustrie).
- Ideal auch zum Schlitzten von Schrauben.
- Zum Trennen/Schlitzten von dünnwandigen Profilen und kurzspanenden Werkstücken aus Stahl, Guss, Nichteisenmetalle, Kunststoffe.

Maximal empfohlene Schnitttiefe ca. 3 mm

DIN 1837A blades comes with fine teeth and tooth shape form A.

Main field of application:

- This shape is mostly used for fine slotting and cutting works (micro-mechanics and jewellery).
- Excellent also for screw slotting.
- For cutting and slotting thin walled profiles and short chipping work pieces made of steel, cast iron, non ferrous metals, plastics.

Maximum recommended cutting depth approx. 3mm

Art. **5.5001**

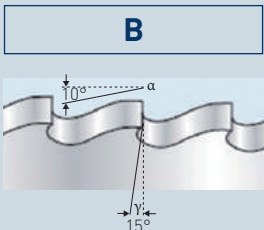

DIN 1838B Blätter kommen mit grobgezahnten Bogenzähnen.

Hauptanwendungsgebiet:

- Die am meisten verwendete Universalverzahnung für Schlitz- und Trennarbeiten von dickwandigen Profilen / Vollmaterial **ab ca. 3 mm**.
- Generell für Arbeiten an langspanenden Werkstücken aus Stahl, Guss, Nichteisenmetalle.

DIN 1838B blades comes with rough teeth and tooth form B.

Main field of application:

- The most widely used universal toothing for slotting and cutting thick walled profiles and solid material **from 3mm**.
- In general for cutting long chipping work pieces made of steel, cast iron, non ferrous metals.

Art. **5.5002**

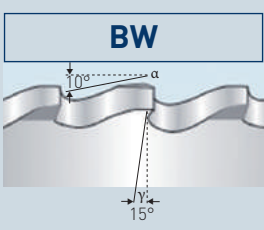

DIN 1838C Blätter kommen je nach Durchmesser mit grobgezahnten Bogenzähnen wechselseitig angefast (Zahnform BW) oder mit Vor- und Nachschneider (Zahnform C).

Diese Zahnformen reduzieren die Schnittkräfte und erlauben hierdurch eine deutlich erhöhte Zerspanleistung gegenüber DIN 1838B

Hauptanwendungsgebiet:

- Für Schlitz und Trennarbeiten von dick- bis sehr dickwandigen Profilen ab ca. 3 mm.
- Speziell hervorragend für Vollmaterial **ab ca. 3 mm**.
- Generell für Arbeiten an langspanenden Werkstücken aus Stahl, Guss, Nichteisenmetalle.

DIN 1838C blades comes with rough teeth and tooth form B additionally, depending on the diameter, alternative top beveled (tooth shape BW) or with precut and finishing cut tooth (tooth shape C).

This tooth forms reduce cutting forces and thus allow a significantly increased cutting performance compared to DIN 1838B

Main field of application:

- For slotting and cutting thick, up to very thick profiles from 3mm.
- Especially excellent for cutting solid material **from 3mm**.
- In general for slotting and cutting long chipping work pieces made of steel, cast iron, non ferrous metals.

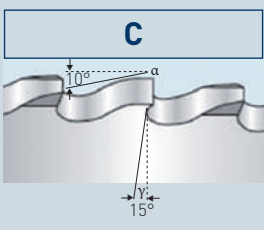

Art. 100
101
102



Metallkreissägeblätter nach DIN 1840, Typ N sind grundsätzlich für mittelharte Metalle, Stähle bis zu 800 N/mm² anwendbar.
Für besonders harte und zähe Werkstoffe empfehlen wir Typ "H" (Preis und Lieferzeit auf Anfrage).
Für besonders weiche und zähe Werkstoffe empfehlen wir Typ "W" (Preis und Lieferzeit auf Anfrage).

Metal-circular saw blades according DIN 1840, type N are for medium hard metals and steels up to 800N/mm².
For particularly tough and hard and tough materials we recommend type "H" (Price and delivery time on request).
For very soft and tough materials we recommend type "W" (Price and delivery time on request).

Richtwerte für den Einsatz HSS-DIN 1840 Typ "N" Kreissägeblätter
Recommended cutting data for HSS-DIN 1840 Typ "N" circular saws

Werkstoffe Materials		Vc (m/min) Schnittgeschwindigkeit Cutting speed	fz (mm/z) Vorschub pro Zahn Feed per tooth
Stahl • Steel	< 500 N/mm ²	25 - 50	0,02 - 0,04
	< 800 N/mm ²	15 - 30	0,02 - 0,03
Guss • Cast Iron		15 - 25	0,02 - 0,05
Aluminium Vollmaterial • Aluminium Solid		400 - 800	0,03 - 0,10
Aluminium Profile • Aluminium Profile		800 - 1600	0,02 - 0,05
Bronze • Bronze		200 - 400	0,02 - 0,06
Kupfer • Copper		160 - 200	0,02 - 0,05
Messing • Brass		200 - 400	0,02 - 0,04
Zinklegierungen • Zinc Alloy		30 - 100	0,02 - 0,08

Festlegung der Schnittgeschwindigkeit Vc
Determination of cutting speed Vc

$$Vc \text{ (m/min)} = \frac{D \cdot \pi \cdot n}{1000}$$

fz (mm/z) = Vorschub pro Zahn · Feed per tooth

D (mm) = Sägendurchmesser · Saw blade diameter

Z = Anzahl der Zähne · Number of teeth

n (min⁻¹) = Drehzahl · rpm

Festlegung der Vorschubgeschwindigkeit Vf
Determination of feed rate Vf

$$Vf \text{ (mm/min)} = fz \cdot n \cdot Z$$

Festlegung der Drehzahl n
Determination

$$n \text{ (min}^{-1}\text{)} = \frac{Vc \cdot 1000}{D \cdot \pi}$$



Art.
100
101
102

Karnasch® METALLKREISSÄGEBLÄTTER NACH DIN METAL CIRCULAR SAW BLADES ACCORDING DIN

Anwendung siehe Seite
Application see page

694



694



694



Ø	Stärke Thickness	Bohrung Bore	Bund Hub	Art.	DIN 1837A	€	Art.	DIN 1838B	€	Art.	DIN 1838C	€
				5.5000	"A"	5.5001	"B"	5.5002	"BW" "C"			
20	0,20	5	10	● 55000.020.020	80 A	9,15	-	-	-	-	-	-
20	0,30	5	10	● 55000.020.030	64 A	8,35	-	-	-	-	-	-
20	0,40	5	10	● 55000.020.040	64 A	8,35	-	-	-	-	-	-
20	0,50	5	10	● 55000.020.050	48 A	7,90	-	-	-	-	-	-
20	0,60	5	10	● 55000.020.060	48 A	7,90	-	-	-	-	-	-
20	0,80	5	10	● 55000.020.080	48 A	7,90	-	-	-	-	-	-
20	1,00	5	10	● 55000.020.100	40 A	8,00	-	-	-	-	-	-
20	1,20	5	10	● 55000.020.120	40 A	8,00	-	-	-	-	-	-
20	1,60	5	10	● 55000.020.160	40 A	9,85	-	-	-	-	-	-
20	2,00	5	10	● 55000.020.200	32 A	10,15	-	-	-	-	-	-
20	2,50	5	10	● 55000.020.250	32 A	10,85	-	-	-	-	-	-
20	3,00	5	10	● 55000.020.300	32 A	11,70	-	-	-	-	-	-
20	4,00	5	10	▲ 55000.020.400	24 A	17,00	-	-	-	-	-	-
25	0,20	8	12	● 55000.025.020	80 A	9,35	-	-	-	-	-	-
25	0,25	8	12	● 55000.025.025	80 A	9,35	-	-	-	-	-	-
25	0,30	8	12	● 55000.025.030	80 A	8,80	-	-	-	-	-	-
25	0,40	8	12	● 55000.025.040	64 A	8,80	-	-	-	-	-	-
25	0,50	8	12	● 55000.025.050	64 A	8,80	-	-	-	-	-	-
25	0,60	8	12	● 55000.025.060	64 A	8,80	-	-	-	-	-	-
25	0,80	8	12	● 55000.025.080	48 A	9,10	-	-	-	-	-	-
25	1,00	8	12	● 55000.025.100	48 A	9,10	-	-	-	-	-	-
25	1,20	8	12	● 55000.025.120	48 A	9,90	-	-	-	-	-	-
25	1,60	8	12	● 55000.025.160	40 A	9,90	-	-	-	-	-	-
25	2,00	8	12	● 55000.025.200	40 A	11,60	-	-	-	-	-	-
25	2,50	8	12	● 55000.025.250	40 A	12,90	-	-	-	-	-	-
25	3,00	8	12	● 55000.025.300	32 A	15,55	-	-	-	-	-	-
25	4,00	8	12	▲ 55000.025.400	32 A	20,00	-	-	-	-	-	-
25	5,00	8	12	▲ 55000.025.500	32 A	22,00	-	-	-	-	-	-
25	6,00	8	12	▲ 55000.025.600	24 A	24,00	-	-	-	-	-	-
32	0,20	8	14	● 55000.032.020	100 A	9,50	-	-	-	-	-	-
32	0,25	8	14	● 55000.032.025	100 A	9,50	-	-	-	-	-	-
32	0,30	8	14	● 55000.032.030	80 A	8,90	-	-	-	-	-	-
32	0,40	8	14	● 55000.032.040	80 A	8,90	-	-	-	-	-	-
32	0,50	8	14	● 55000.032.050	80 A	8,90	-	-	-	-	-	-
32	0,60	8	14	● 55000.032.060	64 A	8,90	-	-	-	-	-	-
32	0,80	8	14	● 55000.032.080	64 A	9,15	-	-	-	-	-	-
32	1,00	8	14	● 55000.032.100	64 A	9,15	-	-	-	-	-	-
32	1,20	8	14	● 55000.032.120	48 A	9,55	-	-	-	-	-	-
32	1,60	8	14	● 55000.032.160	48 A	10,05	-	-	-	-	-	-
32	2,00	8	14	● 55000.032.200	48 A	11,70	-	-	-	-	-	-
32	2,50	8	14	● 55000.032.250	40 A	13,00	-	-	-	-	-	-
32	3,00	8	14	● 55000.032.300	40 A	15,70	-	-	-	-	-	-
32	4,00	8	14	▲ 55000.032.400	40 A	20,00	-	-	-	-	-	-
32	5,00	8	14	▲ 55000.032.500	32 A	22,00	-	-	-	-	-	-
32	6,00	8	14	▲ 55000.032.600	32 A	24,00	-	-	-	-	-	-
40	0,20	10	18	● 55000.040.020	128 A	10,65	-	-	-	-	-	-
40	0,25	10	18	● 55000.040.025	100 A	10,65	-	-	-	-	-	-
40	0,30	10	18	● 55000.040.030	100 A	10,15	-	-	-	-	-	-
40	0,40	10	18	● 55000.040.040	100 A	10,15	-	-	-	-	-	-
40	0,50	10	18	● 55000.040.050	80 A	9,55	-	-	-	-	-	-
40	0,60	10	18	● 55000.040.060	80 A	9,55	-	-	-	-	-	-
40	0,80	10	18	● 55000.040.080	80 A	9,55	-	-	-	-	-	-
40	1,00	10	18	● 55000.040.100	64 A	9,55	-	-	-	-	-	-
40	1,20	10	18	● 55000.040.120	64 A	10,30	-	-	-	-	-	-











696

Weitere Informationen erhalten Sie telefonisch unter +49 33675-7265-0 oder schreiben Sie eine Mail an mail@karnasch.tools.
For more informations please call +49 33675-7265-0 send a mail to mail@karnasch.tools.



Art.
100
101
102

Anwendung siehe Seite
Application see page

Anwendung siehe Seite Application see page				694 			694 			694 		
				Art. 5.5000	DIN 1837A  "A"	€	Art. 5.5001	DIN 1838B  "B"	€	Art. 5.5002	DIN 1838C  "BW"  "C"	€
∅	Stärke Thickness	Bohrung Bore	Bund Hub									
40	1,60	10	18	● 55000.040.160	64 A	10,85	-	-	-	-	-	-
40	2,00	10	18	● 55000.040.200	48 A	12,50	-	-	-	-	-	-
40	2,50	10	18	● 55000.040.250	48 A	13,60	-	-	-	-	-	-
40	3,00	10	18	● 55000.040.300	48 A	16,20	-	-	-	-	-	-
40	4,00	10	18	● 55000.040.400	40 A	20,65	-	-	-	-	-	-
40	5,00	10	18	● 55000.040.500	40 A	24,85	-	-	-	-	-	-
40	6,00	10	18	● 55000.040.600	40 A	27,00	-	-	-	-	-	-
50	0,20	13	32	● 55000.050.020	128 A	13,15	-	-	-	-	-	-
50	0,30	13	25	● 55000.050.030	128 A	11,95	-	-	-	-	-	-
50	0,40	13	25	● 55000.050.040	100 A	11,95	-	-	-	-	-	-
50	0,50	13	25	● 55000.050.050	100 A	11,95	● 55001.050.050	48 B	11,95	-	-	-
50	0,60	13	25	● 55000.050.060	100 A	11,95	● 55001.050.060	48 B	11,95	-	-	-
50	0,80	13	25	● 55000.050.080	80 A	10,85	● 55001.050.080	40 B	10,85	-	-	-
50	1,00	13	25	● 55000.050.100	80 A	10,85	● 55001.050.100	40 B	10,85	● 55002.050.100	40 BW	12,95
50	1,20	13	25	● 55000.050.120	80 A	11,65	● 55001.050.120	40 B	11,65	▲ 55002.050.120	40 BW	14,55
50	1,60	13	25	● 55000.050.160	64 A	12,40	● 55001.050.160	32 B	12,40	● 55002.050.160	32 BW	15,50
50	2,00	13	25	● 55000.050.200	64 A	13,55	● 55001.050.200	32 B	13,55	● 55002.050.200	32 BW	16,90
50	2,50	13	25	● 55000.050.250	64 A	17,30	● 55001.050.250	32 B	17,30	▲ 55002.050.250	32 C	21,00
50	3,00	13	25	● 55000.050.300	48 A	18,00	● 55001.050.300	24 B	18,00	▲ 55002.050.300	24 C	22,00
50	4,00	13	25	● 55000.050.400	48 A	23,35	▲ 55001.050.400	24 B	23,00	▲ 55002.050.400	24 C	29,00
50	5,00	13	25	● 55000.050.500	48 A	27,70	▲ 55001.050.500	24 B	27,00	▲ 55002.050.500	24 C	34,00
50	6,00	13	25	● 55000.050.600	40 A	29,85	▲ 55001.050.600	20 B	29,00	▲ 55002.050.600	20 C	36,00
63	0,25	16	32	▲ 55000.063.025	128 A	13,00	-	-	-	-	-	-
63	0,30	16	32	● 55000.063.030	128 A	13,30	-	-	-	-	-	-
63	0,40	16	32	● 55000.063.040	128 A	13,30	-	-	-	-	-	-
63	0,50	16	32	● 55000.063.050	128 A	13,30	● 55001.063.050	64 B	13,30	-	-	-
63	0,60	16	32	● 55000.063.060	100 A	13,30	● 55001.063.060	48 B	13,30	-	-	-
63	0,80	16	32	● 55000.063.080	100 A	12,75	● 55001.063.080	48 B	12,75	-	-	-
63	1,00	16	32	● 55000.063.100	100 A	12,75	● 55001.063.100	48 B	12,75	● 55002.063.100	48 BW	15,20
63	1,20	16	32	● 55000.063.120	80 A	13,10	● 55001.063.120	40 B	13,10	● 55002.063.120	40 BW	16,35
63	1,50	16	32	● 55000.063.150	80 A	14,55	-	-	-	-	-	-
63	1,60	16	32	● 55000.063.160	80 A	14,55	● 55001.063.160	40 B	14,55	● 55002.063.160	40 BW	19,65
63	2,00	16	32	● 55000.063.200	80 A	16,00	● 55001.063.200	40 B	16,00	● 55002.063.200	40 BW	20,00
63	2,50	16	32	● 55000.063.250	64 A	18,85	● 55001.063.250	32 B	18,85	▲ 55002.063.250	32 C	23,00
63	3,00	16	32	● 55000.063.300	64 A	20,10	● 55001.063.300	32 B	20,10	▲ 55002.063.300	32 C	25,00
63	4,00	16	32	● 55000.063.400	64 A	24,95	● 55001.063.400	32 B	24,95	▲ 55002.063.400	32 BW	31,20
63	5,00	16	32	● 55000.063.500	48 A	29,85	● 55001.063.500	24 B	29,85	-	-	-
63	6,00	16	32	● 55000.063.600	48 A	32,45	● 55001.063.600	24 B	32,45	▲ 55002.063.600	24 C	40,00
80	0,30	22	36	● 55000.080.030	160 A	16,95	-	-	-	-	-	-
80	0,40	22	36	● 55000.080.040	160 A	16,95	-	-	-	-	-	-
80	0,50	22	36	● 55000.080.050	128 A	15,95	● 55001.080.050	64 B	15,95	-	-	-
80	0,60	22	36	● 55000.080.060	128 A	15,95	● 55001.080.060	64 B	15,95	-	-	-
80	0,80	22	36	● 55000.080.080	128 A	15,95	● 55001.080.080	64 B	15,95	-	-	-
80	1,00	22	36	● 55000.080.100	100 A	15,95	● 55001.080.100	48 B	15,95	● 55002.080.100	48 BW	18,95
80	1,20	22	36	● 55000.080.120	100 A	17,00	● 55001.080.120	48 B	17,00	● 55002.080.120	48 BW	21,20
80	1,50	22	36	● 55000.080.150	100 A	17,75	-	-	-	-	-	-
80	1,60	22	36	● 55000.080.160	100 A	17,75	● 55001.080.160	48 B	17,75	● 55002.080.160	48 BW	22,15
80	2,00	22	36	● 55000.080.200	80 A	20,05	● 55001.080.200	40 B	20,05	● 55002.080.200	40 BW	25,05
80	2,50	22	36	● 55000.080.250	80 A	22,20	● 55001.080.250	40 B	22,20	▲ 55002.080.250	40 C	27,00
80	3,00	22	36	● 55000.080.300	80 A	24,80	● 55001.080.300	40 B	24,80	▲ 55002.080.300	40 BW	30,95
80	4,00	22	36	● 55000.080.400	64 A	29,95	● 55001.080.400	32 B	29,95	▲ 55002.080.400	32 BW	37,40
80	5,00	22	36	● 55000.080.500	64 A	33,00	● 55001.080.500	32 B	33,00	▲ 55002.080.500	32 BW	41,25
80	6,00	22	36	● 55000.080.600	64 A	37,35	● 55001.080.600	32 B	37,35	▲ 55002.080.600	32 C	45,00
100	0,50	22	40	● 55000.100.050	160 A	18,85	● 55001.100.050	80 B	18,85	-	-	-

- 1 
- 2 
- 3 
- 4 
- 5 
- 6 
- 7 
- 8 
- 9 
- 10 

Art.
100
101
102

Karnasch® METALLKREISSÄGEBLÄTTER NACH DIN METAL CIRCULAR SAW BLADES ACCORDING DIN

Anwendung siehe Seite
Application see page

694



694



694



Ø	Stärke Thickness	Bohrung Bore	Bund Hub	Art.	DIN 1837A	€	Art.	DIN 1838B	€	Art.	DIN 1838C	€
				5.5000	"A"	5.5001	"B"	5.5002	"C"			
100	0,60	22	40	● 55000.100.060	160 A	18,85	● 55001.100.060	80 B	18,85	-	-	-
100	0,80	22	40	● 55000.100.080	128 A	18,85	● 55001.100.080	64 B	18,85	-	-	-
100	1,00	22	40	● 55000.100.100	128 A	18,85	● 55001.100.100	64 B	18,85	● 55002.100.100	64 BW	22,45
100	1,20	22	40	● 55000.100.120	128 A	19,95	● 55001.100.120	64 B	19,95	● 55002.100.120	64 BW	24,95
100	1,50	22	40	● 55000.100.150	100 A	22,15	-	-	-	-	-	-
100	1,60	22	40	● 55000.100.160	100 A	22,15	● 55001.100.160	48 B	22,15	● 55002.100.160	48 BW	27,65
100	2,00	22	40	● 55000.100.200	100 A	24,70	● 55001.100.200	48 B	24,70	● 55002.100.200	48 BW	30,85
100	2,50	22	40	● 55000.100.250	100 A	27,10	● 55001.100.250	48 B	27,10	● 55002.100.250	48 BW	33,90
100	3,00	22	40	● 55000.100.300	80 A	30,70	● 55001.100.300	40 B	30,70	● 55002.100.300	40 BW	38,30
100	4,00	22	40	● 55000.100.400	80 A	36,80	● 55001.100.400	40 B	36,80	● 55002.100.400	40 BW	46,05
100	5,00	22	40	● 55000.100.500	80 A	41,40	● 55001.100.500	40 B	41,40	▲ 55002.100.500	40 BW	51,70
100	6,00	22	40	-	-	-	▲ 55001.100.600	32 B	46,00	▲ 55002.100.600	32 BW	57,50
125	0,60	22	40	● 55000.125.060	160 A	26,70	● 55001.125.060	80 B	26,70	-	-	-
125	0,80	22	40	● 55000.125.080	160 A	26,00	● 55001.125.080	80 B	26,00	-	-	-
125	1,00	22	40	● 55000.125.100	160 A	26,00	● 55001.125.100	80 B	26,00	● 55002.125.100	80 BW	30,90
125	1,20	22	40	● 55000.125.120	128 A	27,10	● 55001.125.120	64 B	27,10	● 55002.125.120	64 BW	33,90
125	1,60	22	40	● 55000.125.160	128 A	30,00	● 55001.125.160	64 B	30,00	● 55002.125.160	64 BW	37,50
125	2,00	22	40	● 55000.125.200	128 A	32,25	● 55001.125.200	64 B	32,25	● 55002.125.200	64 BW	40,30
125	2,50	22	40	● 55000.125.250	100 A	35,20	● 55001.125.250	48 B	35,20	● 55002.125.250	48 BW	44,00
125	3,00	22	40	● 55000.125.300	100 A	39,70	● 55001.125.300	48 B	39,70	● 55002.125.300	48 BW	49,60
125	4,00	22	40	● 55000.125.400	100 A	47,90	● 55001.125.400	48 B	47,90	● 55002.125.400	48 BW	59,85
125	5,00	22	40	● 55000.125.500	80 A	54,55	● 55001.125.500	40 B	54,55	▲ 55002.125.500	40 BW	66,00
125	6,00	22	40	● 55000.125.600	80 A	62,45	● 55001.125.600	40 B	62,45	▲ 55002.125.600	40 BW	76,00
160	1,00	32	63	● 55000.160.100	160 A	34,95	● 55001.160.100	80 B	34,95	● 55002.160.100	80 C	41,60
160	1,20	32	63	● 55000.160.120	160 A	34,95	● 55001.160.120	80 B	34,95	● 55002.160.120	80 C	43,70
160	1,60	32	63	● 55000.160.160	160 A	37,35	● 55001.160.160	80 B	37,35	● 55002.160.160	80 C	46,70
160	2,00	32	63	● 55000.160.200	128 A	42,70	● 55001.160.200	64 B	42,70	● 55002.160.200	64 C	53,35
160	2,50	32	63	● 55000.160.250	128 A	48,60	● 55001.160.250	64 B	48,60	● 55002.160.250	64 C	60,75
160	3,00	32	63	● 55000.160.300	128 A	55,60	● 55001.160.300	64 B	55,60	● 55002.160.300	64 C	69,45
160	4,00	32	63	● 55000.160.400	100 A	68,05	● 55001.160.400	48 B	68,05	● 55002.160.400	48 C	85,05
160	5,00	32	63	● 55000.160.500	100 A	78,65	● 55001.160.500	48B	78,65	▲ 55002.160.500	48 C	95,00
160	6,00	32	63	● 55000.160.600	100 A	92,75	▲ 55001.160.600	48 B	92,75	▲ 55002.160.600	48 C	112,00
200	1,00	32	63	● 55000.200.100	200 A	49,35	● 55001.200.100	100 B	49,35	● 55002.200.100	100 C	58,75
200	1,20	32	63	● 55000.200.120	200 A	49,35	● 55001.200.120	100 B	49,35	● 55002.200.120	100 C	61,70
200	1,60	32	63	● 55000.200.160	160 A	51,50	● 55001.200.160	80 B	51,50	● 55002.200.160	80 C	64,40
200	2,00	32	63	● 55000.200.200	160 A	55,60	● 55001.200.200	80 B	55,60	● 55002.200.200	80 C	69,45
200	2,50	32	63	● 55000.200.250	160 A	63,45	● 55001.200.250	80 B	63,45	● 55002.200.250	80 C	79,30
200	3,00	32	63	● 55000.200.300	128 A	73,20	● 55001.200.300	64 B	73,20	● 55002.200.300	64 C	91,50
200	4,00	32	63	● 55000.200.400	128 A	96,50	● 55001.200.400	64 B	96,50	● 55002.200.400	64 C	120,60
200	5,00	32	63	● 55000.200.500	128 A	111,15	● 55001.200.500	64 B	111,15	▲ 55002.200.500	64 C	134,00
200	6,00	32	63	● 55000.200.600	100 A	120,90	● 55001.200.600	48 B	120,90	▲ 55002.200.600	48 C	146,00
250	1,60	32	63	-	-	-	▲ 55001.250.160	100 B	76,00	▲ 55002.250.160	100 C	95,00
250	2,00	32	63	▲ 55000.250.200	200 A	74,00	▲ 55001.250.200	100 B	74,00	▲ 55002.250.200	100 C	93,00
250	2,50	32	63	▲ 55000.250.250	160 A	83,00	▲ 55001.250.250	80 B	83,00	-	-	-
250	3,00	32	63	▲ 55000.250.300	160 A	94,00	▲ 55001.250.300	80 B	94,00	▲ 55002.250.300	80 C	117,00
250	4,00	32	63	▲ 55000.250.400	160 A	123,00	▲ 55001.250.400	80 B	123,00	▲ 55002.250.400	80 C	154,00
250	5,00	32	63	▲ 55000.250.500	128 A	144,00	▲ 55001.250.500	64 B	144,00	▲ 55002.250.500	64 C	180,00
250	6,00	32	63	▲ 55000.250.600	128 A	172,00	▲ 55001.250.600	64 B	172,00	▲ 55002.250.600	64 C	215,00
315	2,50	40	80	▲ 55000.315.250	200 A	134,00	-	-	-	-	-	-
315	3,00	40	80	▲ 55000.315.300	200 A	152,00	-	-	-	-	-	-
315	4,00	40	80	▲ 55000.315.400	160 A	189,00	▲ 55001.315.400	80 B	189,00	-	-	-
315	5,00	40	80	▲ 55000.315.500	160 A	225,00	▲ 55001.315.500	80 B	225,00	▲ 55002.315.500	-	281,00
315	6,00	40	80	▲ 55000.315.600	160 A	263,00	▲ 55001.315.600	80 B	263,00	-	-	-

- 1
- 2
- 3
- 4
- 5
- 6
- 7
- 8
- 9
- 10

Art.
100
101
102

VOLLHARTMETALL-KREISSÄGEBLÄTTER NACH DIN

Präzisions-Verzahnung mit seitlichem Hohlschliff im Spiegelschliffverfahren

SOLID CARBIDE METAL CIRCULAR SAW BLADES ACCORDING TO DIN

Precision-toothing and hollow ground in mirror finishing quality

Passende Aufnahmehalter / Fräsdorne siehe Seite 708
Suitable saw blade retainer / milling arbors see page 708



1



2



3



4



5



6



7



8



9



10



Art.
100
101
102

Vollhartmetall-Kreissägeblätter sollten nur auf stabilen und schwingungsarmen Maschinen eingesetzt werden (vorzugsweise Fräsmaschinen).

Die Kreissägeblätter müssen zwischen exact planlaufenden, möglichst großen Spannflanschen fest eingespannt werden (Aufnahmehalter siehe Seite 708).

Seitendruck sowie der einsatz auf Maschinen mit Handvorschub sind zu vermeiden.

Für die Stahlzerspanung wird eine besonders fette Kühlung empfohlen. Unzureichende Kühlung führt zu vorzeitigem Werkzeugverschleiß, zur Rissbildung und zum Werkzeugbruch.

Bei der Zerspanung von NE-Metallen kann auch eine Sprühnebelschmierung eingesetzt werden.

Grauguss und Kunststoffe sind trocken zu Zerspanen.

Wird dies beachtet kann die Schnittgeschwindigkeit gegenüber HSS-DIN Kreissägeblättern bis zum 4-fachen gesteigert werden.

Full carbide circular saw blades should only be used on stable and low-vibration machines (preferably milling machines).

The circular saw blades must be firmly clamped between precisely evenly running clamping flanges that are as large as possible (receptacle holders, see page 708).

Lateral pressure and use on machines with manual infeed must be avoided.

For steel machining, particularly fast cooling is recommended. Insufficient cooling will lead to premature tool wear, crack formation and tool break.

When chipping NF metals, spray mist lubrication can be used.

Cast iron and plastics must be machined dry.

If this is observed, the cutting speed as compared to the HSS-DIN circular saw blades can be increased up to four-fold.

Art. **5.6000**

A

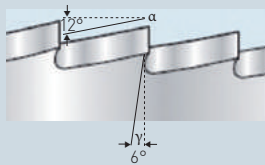

Ähnlich DIN 1837 Blätter kommen mit feingezahnten Zähnen.

Hauptanwendungsgebiet:

- Feine Schlitz- und Trennarbeiten (Feinmechanik, Schmuckindustrie).
- Ideal auch zum Schlitzten von Schrauben.
- Zum Trennen/Schlitzten von dünnwandigen Profilen und kurzspanenden Werkstücken aus Edelstahl, Stahl, Guss, Nichteisenmetalle, Kunststoffe.

Maximal empfohlene Schnitttiefe ca. 3 mm

- Somit generell nur für geringe Bearbeitungstiefen oder kurze Schlitzlängen.
- Vorschub pro Zahn: 0,005-0,05 je nach Werkstoff, dicke und Gesamtstarrheit (genauere Daten siehe Tabelle nächste Seite).

Similar DIN 1837 blades comes with fine teeth.

Main field of application:

- This shape is mostly used for fine slotting and cutting works (micro-mechanics and jewellery).
- Excellent also for screw slotting.
- For cutting and slotting thin walled profiles and short chipping work pieces made of stainless steel, steel, cast iron, non ferrous metals, plastics.

Maximum recommended cutting depth approx. 3 mm

- So basically for low machining depths or short slots.
- Feed per tooth: 0,005-0,05 according to material, thickness and global rigidity (more precise data see next page).

Art. **5.6001**

B

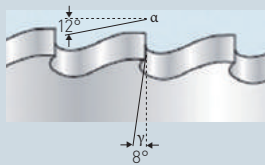

Ähnlich DIN 1838 Blätter kommen mit grobgezahnten Zähnen.

Hauptanwendungsgebiet:

- Die am meisten verwendete Universalverzahnung für Schlitz- und Trennarbeiten von dickwandigen Profilen / Vollmaterial **ab ca. 3 mm**.
- Generell für Arbeiten an langspanenden Werkstücken aus Edelstahl, Stahl, Guss, Nichteisenmetalle.
- Somit generell nur für große Bearbeitungstiefen oder große Schlitzlängen.
- Vorschub pro Zahn: 0,01-0,1 je nach Werkstoff, dicke und Gesamtstarrheit (genauere Daten siehe Tabelle nächste Seite).

Similar DIN 1838 blades comes with rough teeth.

Main field of application:

- The most widely used universal toothing for slotting and cutting thick walled profiles and solid material **from 3 mm**.
- In general for cutting long chipping work pieces made of stainless steel, steel, cast iron, non ferrous metals.
- So basically for deep machining depths or long slots
- Feed per tooth: 0,01-0,1 according to material, thickness and global rigidity (more precise data see next page).



Art.
100
101
102

Im Idealfall sollten immer 2-3 Zähne im Einsatz sein
Ideally 2-3 teeth in contact

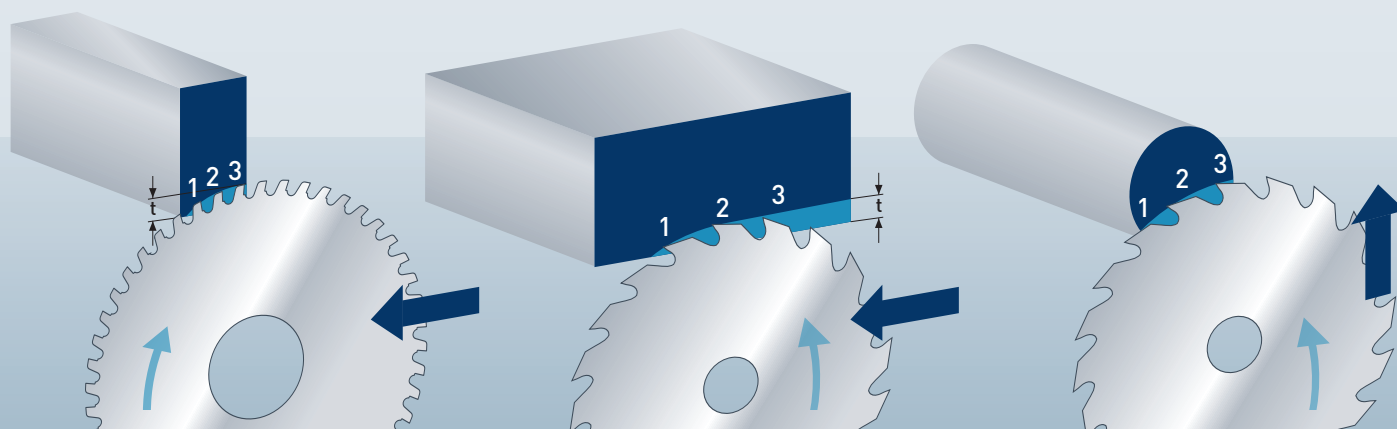

Richtwerte für den Einsatz von Vollhartmetall-Kreissägeblättern nach DIN
Recommended cutting data for solid carbide circular saw blades according DIN

Material		Kühlung Cooling	Schnittgeschwindigkeit Cutting speed V_c m/min	Vorschub Feed f_z mm/u mm/rev	Verzahnungswahl Teeth selection / cutting feed
Automatenstahl	free-cutting steel	O / E	120 - 240	0,020 - 0,040	Typ 5.6000 Für geringe Bearbeitungstiefen oder kurze Schlitzlängen. Vorschub pro Zahn: 0,005 - 0,05** For low machining depth or short slots. Feed per tooth: 0,005 - 0,05**
Stahl	Steel	< 600 N/mm ²	O / E	100 - 200	
Stahl	Steel	< 800 N/mm ²	O / E	80 - 160	
Stahl	Steel	< 1000 N/mm ²	O / E	60 - 120	
Stahl	Steel	> 1000 N/mm ²	O / E	40 - 80	
Edelstahl	Stainless steel	O / E	50 - 100	0,005 - 0,015	
Warmfester Stahl	High temp alloy	O / E	25 - 60	0,005 - 0,015	
Legierter Werkzeugstahl	Alloy tool steel	O / E	15 - 40	0,005 - 0,012	
Gusseisen	Cast iron	A / E	60 - 120	0,006 - 0,023	
Aluminium Si <12%	Aluminium Si <12%	O / E	150 - 600	0,010 - 0,040	
Aluminium Si >12%	Aluminium Si >12%	O / E	80 - 300	0,006 - 0,030	Typ 5.6001 Für große Bearbeitungstiefen oder große Schlitzlängen. Vorschub pro Zahn: 0,01 - 0,1** For deep machining depth or long slots. Feed per tooth: 0,01 - 0,1**
Titan	Titanium	O / E	30 - 60	0,003 - 0,008	
Kupfer	Copper	A / O / E	80 - 300	0,020 - 0,040	
Messing	Brass	A / O / E	80 - 300	0,020 - 0,040	
Bronze	Bronze	A / O / E	80 - 300	0,020 - 0,040	
Thermoplaste	Thermoplastics	A	200 - 700	0,010 - 0,040	** je nach Werkstoff, Dicke und Gesamtstarrheit ** According to material, thickness and global rigidity
Duroplaste	Duroplastics	A	150 - 600	0,010 - 0,040	

*O = Schneidöl / cutting oil
*E = Emulsion
*A = Trocken (Pressluft), air

Verwenden Sie ein gutes Schneidöl; siehe ab Seite 711
Use good cutting oil; see from page 711

Festlegung der Schnittgeschwindigkeit V_c
Determination of cutting speed V_c

$$V_c \text{ (m/min)} = \frac{D \cdot \pi \cdot n}{1000}$$

Festlegung der Vorschubgeschwindigkeit V_f
Determination of feed rate V_f

$$V_f \text{ (mm/min)} = f_z \cdot n \cdot Z$$

Festlegung der Drehzahl n
Determination

$$n \text{ (min}^{-1}\text{)} = \frac{V_c \cdot 1000}{D \cdot \pi}$$

f_z (mm/z) = Vorschub pro Zahn · Feed per tooth
 D (mm) = Sägendurchmesser · Saw blade diameter
 Z = Anzahl der Zähne · Number of teeth
 n (min⁻¹) = Drehzahl · rpm



Art.
100
101
102

Karnasch® VOLLHARTMETALL-KREISSÄGEBLÄTTER NACH DIN SOLID CARBIDE METAL CIRCULAR SAW BLADES ACCORDING DIN

Anwendung siehe Seite
Application see page

700



700



Ø	Stärke Thickness	Bohrung Bore	700			700		
			Art. 5.6000	DIN 1837A "A"	€	Art. 5.6001	DIN 1838B "B"	€
15	0,10	5	● 56000.015.010	64 A	20,70	-	-	-
15	0,15	5	● 56000.015.015	64 A	15,80	-	-	-
15	0,20	5	● 56000.015.020	64 A	12,30	● 56001.015.020	20 B	12,30
15	0,25	5	● 56000.015.025	64 A	12,30	● 56001.015.025	20 B	12,30
15	0,30	5	● 56000.015.030	64 A	12,30	● 56001.015.030	20 B	12,30
15	0,35	5	● 56000.015.035	64 A	12,90	-	-	-
15	0,40	5	● 56000.015.040	64 A	12,90	● 56001.015.040	20 B	12,90
15	0,45	5	● 56000.015.045	48 A	13,45	-	-	-
15	0,50	5	● 56000.015.050	48 A	13,45	● 56001.015.050	20 B	13,45
15	0,60	5	● 56000.015.060	48 A	14,05	● 56001.015.060	20 B	14,05
15	0,70	5	● 56000.015.070	48 A	15,80	● 56001.015.070	20 B	15,80
15	0,80	5	● 56000.015.080	40 A	16,35	● 56001.015.080	20 B	16,35
15	0,90	5	● 56000.015.090	40 A	17,20	● 56001.015.090	20 B	17,20
15	1,00	5	● 56000.015.100	40 A	17,85	● 56001.015.100	20 B	17,85
15	1,10	5	● 56000.015.110	40 A	18,40	-	-	-
15	1,20	5	● 56000.015.120	40 A	19,30	● 56001.015.120	20 B	19,30
15	1,30	5	● 56000.015.130	40 A	21,05	-	-	-
15	1,40	5	● 56000.015.140	40 A	21,50	-	-	-
15	1,50	5	● 56000.015.150	40 A	22,70	● 56001.015.150	20 B	22,70
15	1,60	5	● 56000.015.160	40 A	23,30	● 56001.015.160	20 B	23,30
15	1,70	5	● 56000.015.170	40 A	24,55	-	-	-
15	1,80	5	● 56000.015.180	40 A	25,50	● 56001.015.180	20 B	25,50
15	1,90	5	● 56000.015.190	40 A	26,90	-	-	-
15	2,00	5	● 56000.015.200	40 A	27,50	● 56001.015.200	20 B	27,50
15	2,50	5	● 56000.015.250	40 A	34,85	● 56001.015.250	20 B	34,85
15	3,00	5	● 56000.015.300	40 A	40,30	● 56001.015.300	20 B	40,30
15	3,50	5	● 56000.015.350	24 A	42,95	-	-	-
15	4,00	5	● 56000.015.400	24 A	52,75	● 56001.015.400	20 B	52,75
15	5,00	5	● 56000.015.500	24 A	65,00	● 56001.015.500	20 B	65,00
15	6,00	5	● 56000.015.600	24 A	77,10	● 56001.015.600	20 B	77,10
20	0,10	5	● 56000.020.010	80 A	22,75	-	-	-
20	0,15	5	● 56000.020.015	80 A	17,55	-	-	-
20	0,20	5	● 56000.020.020	80 A	14,05	● 56001.020.020	20 B	14,05
20	0,25	5	● 56000.020.025	64 A	14,05	● 56001.020.025	20 B	14,05
20	0,30	5	● 56000.020.030	64 A	14,05	● 56001.020.030	20 B	14,05
20	0,35	5	● 56000.020.035	64 A	14,65	-	-	-
20	0,40	5	● 56000.020.040	64 A	14,65	● 56001.020.040	20 B	14,65
20	0,45	5	● 56000.020.045	48 A	15,40	-	-	-
20	0,50	5	● 56000.020.050	48 A	15,40	● 56001.020.050	20 B	15,40
20	0,60	5	● 56000.020.060	48 A	15,40	● 56001.020.060	20 B	15,40
20	0,70	5	● 56000.020.070	48 A	17,85	● 56001.020.070	20 B	17,85
20	0,80	5	● 56000.020.080	40 A	17,85	● 56001.020.080	20 B	17,85
20	0,90	5	● 56000.020.090	40 A	18,40	● 56001.020.090	20 B	18,40
20	1,00	5	● 56000.020.100	40 A	20,30	● 56001.020.100	20 B	20,30
20	1,10	5	● 56000.020.110	40 A	21,50	-	-	-
20	1,20	5	● 56000.020.120	40 A	21,50	● 56001.020.120	20 B	21,50
20	1,30	5	● 56000.020.130	40 A	22,75	-	-	-
20	1,40	5	● 56000.020.140	40 A	24,55	-	-	-
20	1,50	5	● 56000.020.150	40 A	24,55	● 56001.020.150	20 B	24,55
20	1,60	5	● 56000.020.160	40 A	25,80	● 56001.020.160	20 B	25,80
20	1,70	5	● 56000.020.170	32 A	27,05	-	-	-
20	1,80	5	● 56000.020.180	32 A	28,30	● 56001.020.180	20 B	28,30
20	1,90	5	● 56000.020.190	32 A	29,20	-	-	-
20	2,00	5	● 56000.020.200	32 A	30,40	● 56001.020.200	20 B	30,40
20	2,50	5	● 56000.020.250	32 A	35,60	● 56001.020.250	20 B	35,60
20	3,00	5	● 56000.020.300	32 A	40,90	● 56001.020.300	20 B	40,90
20	3,50	5	● 56000.020.350	24 A	45,40	-	-	-
20	4,00	5	● 56000.020.400	24 A	54,00	● 56001.020.400	20 B	54,00
20	5,00	5	● 56000.020.500	24 A	67,50	● 56001.020.500	20 B	67,50
20	6,00	5	● 56000.020.600	24 A	81,00	● 56001.020.600	20 B	81,00
25	0,10	8	● 56000.025.010	80 A	23,75	-	-	-
25	0,15	8	● 56000.025.015	80 A	18,10	-	-	-
25	0,20	8	● 56000.025.020	80 A	14,65	● 56001.025.020	20 B	14,65
25	0,25	8	● 56000.025.025	80 A	14,65	● 56001.025.025	20 B	14,65
25	0,30	8	● 56000.025.030	80 A	14,65	● 56001.025.030	20 B	14,65
25	0,35	8	● 56000.025.035	64 A	15,40	-	-	-
25	0,40	8	● 56000.025.040	64 A	15,95	● 56001.025.040	20 B	15,95
25	0,45	8	● 56000.025.045	64 A	18,40	-	-	-
25	0,50	8	● 56000.025.050	64 A	18,40	● 56001.025.050	20 B	18,40
25	0,60	8	● 56000.025.060	64 A	18,40	● 56001.025.060	20 B	18,40
25	0,70	8	● 56000.025.070	48 A	20,30	● 56001.025.070	20 B	20,30
25	0,80	8	● 56000.025.080	48 A	22,75	● 56001.025.080	20 B	22,75
25	0,90	8	● 56000.025.090	48 A	24,55	● 56001.025.090	20 B	24,55
25	1,00	8	● 56000.025.100	48 A	24,55	● 56001.025.100	20 B	24,55
25	1,10	8	● 56000.025.110	48 A	26,90	-	-	-



Art.
100
101
102

Anwendung siehe Seite
Application see page

700



700



Ø	Stärke Thickness	Bohrung Bore	700			700		
			Art. 5.6000	DIN 1837A "A"	€	Art. 5.6001	DIN 1838B "B"	€
25	1,20	8	• 56000.025.120	48 A	27,50	• 56001.025.120	20 B	27,50
25	1,30	8	• 56000.025.130	40 A	29,45	-	-	-
25	1,40	8	• 56000.025.140	40 A	30,70	-	-	-
25	1,50	8	• 56000.025.150	40 A	30,70	• 56001.025.150	20 B	30,70
25	1,60	8	• 56000.025.160	40 A	33,80	• 56001.025.160	20 B	33,80
25	1,70	8	• 56000.025.170	40 A	33,80	-	-	-
25	1,80	8	• 56000.025.180	40 A	35,00	• 56001.025.180	20 B	35,00
25	1,90	8	• 56000.025.190	40 A	37,45	-	-	-
25	2,00	8	• 56000.025.200	40 A	38,70	• 56001.025.200	20 B	38,70
25	2,50	8	• 56000.025.250	40 A	45,00	• 56001.025.250	20 B	45,00
25	3,00	8	• 56000.025.300	32 A	50,25	• 56001.025.300	20 B	50,25
25	3,50	8	• 56000.025.350	32 A	59,60	-	-	-
25	4,00	8	• 56000.025.400	32 A	67,75	• 56001.025.400	20 B	67,75
25	5,00	8	• 56000.025.500	32 A	81,20	• 56001.025.500	20 B	81,20
25	6,00	8	• 56000.025.600	24 A	95,80	• 56001.025.600	20 B	95,80
30	0,10	8	• 56000.030.010	100 A	28,05	-	-	-
30	0,15	8	• 56000.030.015	100 A	22,20	-	-	-
30	0,20	8	• 56000.030.020	100 A	18,70	• 56001.030.020	30 B	18,70
30	0,25	8	• 56000.030.025	100 A	18,70	• 56001.030.025	30 B	18,70
30	0,30	8	• 56000.030.030	80 A	18,70	• 56001.030.030	30 B	18,70
30	0,35	8	• 56000.030.035	80 A	19,30	-	-	-
30	0,40	8	• 56000.030.040	80 A	19,30	• 56001.030.040	30 B	19,30
30	0,45	8	• 56000.030.045	80 A	19,90	-	-	-
30	0,50	8	• 56000.030.050	80 A	19,90	• 56001.030.050	30 B	19,90
30	0,60	8	• 56000.030.060	64 A	21,50	• 56001.030.060	30 B	21,50
30	0,70	8	• 56000.030.070	64 A	25,15	• 56001.030.070	30 B	25,15
30	0,80	8	• 56000.030.080	64 A	25,70	• 56001.030.080	24 B	25,70
30	0,90	8	• 56000.030.090	64 A	27,50	• 56001.030.090	24 B	27,50
30	1,00	8	• 56000.030.100	64 A	28,05	• 56001.030.100	24 B	28,05
30	1,10	8	• 56000.030.110	48 A	30,40	-	-	-
30	1,20	8	• 56000.030.120	48 A	31,55	• 56001.030.120	24 B	31,55
30	1,30	8	• 56000.030.130	48 A	34,50	-	-	-
30	1,40	8	• 56000.030.140	48 A	36,25	-	-	-
30	1,50	8	• 56000.030.150	48 A	37,45	• 56001.030.150	24 B	37,40
30	1,60	8	• 56000.030.160	48 A	39,15	• 56001.030.160	24 B	39,15
30	1,70	8	• 56000.030.170	48 A	40,90	-	-	-
30	1,80	8	• 56000.030.180	48 A	41,50	• 56001.030.180	24 B	41,50
30	1,90	8	• 56000.030.190	48 A	43,25	-	-	-
30	2,00	8	• 56000.030.200	48 A	44,40	• 56001.030.200	24 B	44,40
30	2,50	8	• 56000.030.250	40 A	50,85	• 56001.030.250	24 B	50,85
30	3,00	8	• 56000.030.300	40 A	57,25	• 56001.030.300	24 B	57,25
30	3,50	8	• 56000.030.350	40 A	67,75	-	-	-
30	4,00	8	• 56000.030.400	40 A	77,10	• 56001.030.400	24 B	77,10
30	5,00	8	• 56000.030.500	32 A	92,30	• 56001.030.500	24 B	92,30
30	6,00	8	• 56000.030.600	32 A	107,50	• 56001.030.600	24 B	107,50
40	0,10	10	• 56000.040.010	128 A	35,60	-	-	-
40	0,15	10	• 56000.040.015	128 A	29,45	-	-	-
40	0,20	10	• 56000.040.020	128 A	25,80	• 56001.040.020	40 B	25,80
40	0,25	10	• 56000.040.025	100 A	25,80	• 56001.040.025	40 B	25,80
40	0,30	10	• 56000.040.030	100 A	25,80	• 56001.040.030	40 B	25,80
40	0,35	10	• 56000.040.035	100 A	25,80	-	-	-
40	0,40	10	• 56000.040.040	100 A	27,05	• 56001.040.040	40 B	27,05
40	0,45	10	• 56000.040.045	80 A	28,65	-	-	-
40	0,50	10	• 56000.040.050	80 A	28,65	• 56001.040.050	40 B	28,65
40	0,60	10	• 56000.040.060	80 A	29,45	• 56001.040.060	40 B	29,45
40	0,70	10	• 56000.040.070	80 A	33,30	• 56001.040.070	40 B	33,30
40	0,80	10	• 56000.040.080	80 A	33,90	• 56001.040.080	32 B	33,90
40	0,90	10	• 56000.040.090	64 A	35,00	• 56001.040.090	32 B	35,00
40	1,00	10	• 56000.040.100	64 A	36,25	• 56001.040.100	32 B	36,25
40	1,10	10	• 56000.040.110	64 A	37,45	-	-	-
40	1,20	10	• 56000.040.120	64 A	38,70	• 56001.040.120	32 B	38,70
40	1,30	10	• 56000.040.130	64 A	39,25	-	-	-
40	1,40	10	• 56000.040.140	64 A	41,70	-	-	-
40	1,50	10	• 56000.040.150	64 A	42,95	• 56001.040.150	32 B	42,95
40	1,60	10	• 56000.040.160	64 A	44,20	• 56001.040.160	32 B	44,20
40	1,70	10	• 56000.040.170	48 A	46,65	-	-	-
40	1,80	10	• 56000.040.180	48 A	47,85	• 56001.040.180	24 B	47,85
40	1,90	10	• 56000.040.190	48 A	49,10	-	-	-
40	2,00	10	• 56000.040.200	48 A	50,25	• 56001.040.200	24 B	50,25
40	2,50	10	• 56000.040.250	48 A	63,80	• 56001.040.250	24 B	63,80
40	3,00	10	• 56000.040.300	48 A	73,60	• 56001.040.300	24 B	73,60
40	3,50	10	• 56000.040.350	40 A	82,20	-	-	-
40	4,00	10	• 56000.040.400	40 A	90,80	• 56001.040.400	20 B	90,80
40	5,00	10	• 56000.040.500	40 A	107,50	• 56001.040.500	20 B	107,50
40	6,00	10	• 56000.040.600	40 A	123,85	• 56001.040.600	20 B	123,85



Art.
100
101
102

Anwendung siehe Seite
Application see page

700



700



Ø	Stärke Thickness	Bohrung Bore	700			700		
			Art. 5.6000	DIN 1837A "A"	€	Art. 5.6001	DIN 1838B "B"	€
50	0,20	13	● 56000.050.020	128 A	39,50	-	-	-
50	0,25	13	● 56000.050.025	128 A	37,40	-	-	-
50	0,30	13	● 56000.050.030	128 A	34,35	-	-	-
50	0,35	13	● 56000.050.035	100 A	34,35	-	-	-
50	0,40	13	● 56000.050.040	100 A	34,35	● 56001.050.040	48 B	34,35
50	0,45	13	● 56000.050.045	100 A	35,60	-	-	-
50	0,50	13	● 56000.050.050	100 A	35,60	● 56001.050.050	48 B	35,60
50	0,60	13	● 56000.050.060	100 A	35,60	● 56001.050.060	48 B	35,60
50	0,70	13	● 56000.050.070	80 A	37,45	● 56001.050.070	40 B	37,45
50	0,80	13	● 56000.050.080	80 A	40,50	● 56001.050.080	40 B	40,50
50	0,90	13	● 56000.050.090	80 A	41,70	● 56001.050.090	40 B	41,70
50	1,00	13	● 56000.050.100	80 A	42,95	● 56001.050.100	40 B	42,95
50	1,10	13	● 56000.050.110	80 A	44,20	-	-	-
50	1,20	13	● 56000.050.120	80 A	45,40	● 56001.050.120	40 B	45,40
50	1,30	13	● 56000.050.130	64 A	50,95	-	-	-
50	1,40	13	● 56000.050.140	64 A	52,15	-	-	-
50	1,50	13	● 56000.050.150	64 A	54,60	● 56001.050.150	32 B	54,60
50	1,60	13	● 56000.050.160	64 A	55,85	● 56001.050.160	32 B	60,10
50	1,70	13	● 56000.050.170	64 A	56,45	-	-	-
50	1,80	13	● 56000.050.180	64 A	60,10	● 56001.050.180	32 B	60,10
50	1,90	13	● 56000.050.190	64 A	60,10	-	-	-
50	2,00	13	● 56000.050.200	64 A	62,60	● 56001.050.200	32 B	62,60
50	2,50	13	● 56000.050.250	64 A	76,05	● 56001.050.250	32 B	76,05
50	3,00	13	● 56000.050.300	48 A	88,30	● 56001.050.300	24 B	88,30
50	3,50	13	● 56000.050.350	48 A	100,60	-	-	-
50	4,00	13	● 56000.050.400	48 A	106,75	● 56001.050.400	24 B	106,75
50	5,00	13	● 56000.050.500	48 A	130,05	● 56001.050.500	24 B	130,05
50	6,00	13	● 56000.050.600	40 A	153,05	● 56001.050.600	20 B	153,05
63	0,20	16	● 56000.063.020	160 A	57,25	-	-	-
63	0,25	16	● 56000.063.025	128 A	52,60	-	-	-
63	0,30	16	● 56000.063.030	128 A	48,50	-	-	-
63	0,35	16	● 56000.063.035	128 A	48,50	-	-	-
63	0,40	16	● 56000.063.040	128 A	48,50	● 56001.063.040	64 B	48,50
63	0,45	16	● 56000.063.045	128 A	47,30	-	-	-
63	0,50	16	● 56000.063.050	128 A	47,30	● 56001.063.050	64 B	47,30
63	0,60	16	● 56000.063.060	100 A	48,50	● 56001.063.060	48 B	48,50
63	0,70	16	● 56000.063.070	100 A	54,60	● 56001.063.070	48 B	54,60
63	0,80	16	● 56000.063.080	100 A	57,25	● 56001.063.080	48 B	57,25
63	0,90	16	● 56000.063.090	100 A	59,60	● 56001.063.090	48 B	59,60
63	1,00	16	● 56000.063.100	100 A	60,80	● 56001.063.100	48 B	60,75
63	1,10	16	● 56000.063.110	80 A	65,00	-	-	-
63	1,20	16	● 56000.063.120	80 A	66,60	● 56001.063.120	40 B	66,60
63	1,30	16	● 56000.063.130	80 A	68,35	-	-	-
63	1,40	16	● 56000.063.140	80 A	69,55	-	-	-
63	1,50	16	● 56000.063.150	80 A	71,15	● 56001.063.150	40 B	71,15
63	1,60	16	● 56000.063.160	80 A	74,85	● 56001.063.160	40 B	74,85
63	1,70	16	● 56000.063.170	80 A	78,50	-	-	-
63	1,80	16	● 56000.063.180	80 A	79,75	● 56001.063.180	40 B	79,75
63	1,90	16	● 56000.063.190	80 A	83,40	-	-	-
63	2,00	16	● 56000.063.200	80 A	84,10	● 56001.063.200	40 B	84,10
63	2,50	16	● 56000.063.250	64 A	101,65	● 56001.063.250	32 B	101,65
63	3,00	16	● 56000.063.300	64 A	115,10	● 56001.063.300	32 B	115,10
63	3,50	16	● 56000.063.350	64 A	133,70	-	-	-
63	4,00	16	● 56000.063.400	64 A	148,35	● 56001.063.400	32 B	148,35
63	5,00	16	● 56000.063.500	48 A	178,70	● 56001.063.500	24 B	178,70
63	6,00	16	● 56000.063.600	48 A	209,10	● 56001.063.600	24 B	209,10
80	0,30	22	● 56000.080.030	160 A	112,25	-	-	-
80	0,35	22	● 56000.080.035	160 A	99,30	-	-	-
80	0,40	22	● 56000.080.040	160 A	87,60	-	-	-
80	0,45	22	● 56000.080.045	128 A	79,15	-	-	-
80	0,50	22	● 56000.080.050	128 A	79,15	▲ 56001.080.050	64 B	59,00
80	0,60	22	● 56000.080.060	128 A	76,70	● 56001.080.060	64 B	76,70
80	0,70	22	● 56000.080.070	128 A	83,40	● 56001.080.070	64 B	83,40
80	0,80	22	● 56000.080.080	128 A	83,40	● 56001.080.080	64 B	83,40
80	0,90	22	● 56000.080.090	100 A	87,10	● 56001.080.090	48 B	87,10
80	1,00	22	● 56000.080.100	100 A	87,10	● 56001.080.100	48 B	87,10
80	1,10	22	● 56000.080.110	100 A	89,55	-	-	-
80	1,20	22	● 56000.080.120	100 A	93,25	● 56001.080.120	48 B	93,25
80	1,30	22	● 56000.080.130	100 A	96,90	-	-	-
80	1,40	22	● 56000.080.140	100 A	100,60	-	-	-
80	1,50	22	● 56000.080.150	100 A	101,65	● 56001.080.150	48 B	101,65
80	1,60	22	● 56000.080.160	100 A	104,00	● 56001.080.160	48 B	104,00
80	1,70	22	● 56000.080.170	80 A	113,30	-	-	-
80	1,80	22	● 56000.080.180	80 A	114,50	● 56001.080.180	40 B	114,50
80	1,90	22	● 56000.080.190	80 A	117,75	-	-	-



Art.
100
101
102

Anwendung siehe Seite
Application see page

700



700



Ø	Stärke Thickness	Bohrung Bore	700			700		
			Art. 5.6000	DIN 1837A "A"	€	Art. 5.6001	DIN 1838B "B"	€
80	2,00	22	● 56000.080.200	80 A	121,45	● 56001.080.200	40 B	121,45
80	2,50	22	● 56000.080.250	80 A	143,50	● 56001.080.250	40 B	143,50
80	3,00	22	● 56000.080.300	80 A	163,55	● 56001.080.300	40 B	163,55
80	3,50	22	● 56000.080.350	64 A	190,10	-	-	-
80	4,00	22	● 56000.080.400	64 A	213,75	● 56001.080.400	32 B	213,75
80	5,00	22	● 56000.080.500	64 A	264,00	● 56001.080.500	32 B	264,00
80	6,00	22	● 56000.080.600	64 A	314,20	● 56001.080.600	32 B	314,20
100	0,50	22	● 56000.100.050	160 A	144,70	-	-	-
100	0,60	22	● 56000.100.060	160 A	139,85	● 56001.100.060	80 B	139,85
100	0,70	22	● 56000.100.070	128 A	133,70	● 56001.100.070	64 B	133,70
100	0,80	22	● 56000.100.080	128 A	118,00	● 56001.100.080	64 B	118,00
100	0,90	22	● 56000.100.090	128 A	120,20	● 56001.100.090	64 B	120,20
100	1,00	22	● 56000.100.100	128 A	115,65	● 56001.100.100	64 B	115,65
100	1,10	22	● 56000.100.110	128 A	123,85	-	-	-
100	1,20	22	● 56000.100.120	128 A	126,15	● 56001.100.120	64 B	126,15
100	1,30	22	● 56000.100.130	100 A	133,15	-	-	-
100	1,40	22	● 56000.100.140	100 A	137,85	-	-	-
100	1,50	22	● 56000.100.150	100 A	142,50	● 56001.100.150	48 B	142,50
100	1,60	22	● 56000.100.160	100 A	147,20	● 56001.100.160	48 B	147,20
100	1,70	22	● 56000.100.170	100 A	154,55	-	-	-
100	1,80	22	● 56000.100.180	100 A	163,55	● 56001.100.180	48 B	163,55
100	1,90	22	● 56000.100.190	100 A	175,25	-	-	-
100	2,00	22	● 56000.100.200	100 A	177,55	● 56001.100.200	48 B	177,55
100	2,50	22	● 56000.100.250	100 A	207,95	● 56001.100.250	48 B	207,95
100	3,00	22	● 56000.100.300	80 A	247,65	● 56001.100.300	40 B	247,65
100	3,50	22	● 56000.100.350	80 A	283,85	-	-	-
100	4,00	22	● 56000.100.400	80 A	318,85	● 56001.100.400	40 B	318,85
100	5,00	22	● 56000.100.500	80 A	388,95	● 56001.100.500	40 B	388,95
100	6,00	22	● 56000.100.600	64 A	461,40	● 56001.100.600	32 B	461,40
125	0,60	22	● 56000.125.060	160 A	213,40	-	-	-
125	0,70	22	● 56000.125.070	160 A	208,50	-	-	-
125	0,80	22	● 56000.125.080	160 A	206,05	● 56001.125.080	80 B	206,05
125	0,90	22	● 56000.125.090	160 A	202,40	● 56001.125.090	80 B	202,40
125	1,00	22	● 56000.125.100	160 A	189,25	● 56001.125.100	80 B	189,25
125	1,10	22	● 56000.125.110	128 A	196,25	-	-	-
125	1,20	22	● 56000.125.120	128 A	200,90	● 56001.125.120	64 B	200,90
125	1,40	22	● 56000.125.140	128 A	215,85	-	-	-
125	1,50	22	● 56000.125.150	128 A	224,45	● 56001.125.150	64 B	224,45
125	1,60	22	● 56000.125.160	128 A	233,00	● 56001.125.160	64 B	233,00
125	1,80	22	● 56000.125.180	128 A	251,45	● 56001.125.180	64 B	251,45
125	2,00	22	● 56000.125.200	128 A	272,25	● 56001.125.200	64 B	272,25
125	2,50	22	● 56000.125.250	100 A	320,10	● 56001.125.250	48 B	320,10
125	3,00	22	● 56000.125.300	100 A	377,75	● 56001.125.300	48 B	377,75
125	3,50	22	● 56000.125.350	100 A	434,15	-	-	-
125	4,00	22	● 56000.125.400	100 A	494,25	● 56001.125.400	48 B	494,25
125	5,00	22	● 56000.125.500	100 A	571,50	● 56001.125.500	40 B	571,50
125	6,00	22	● 56000.125.600	100 A	699,05	● 56001.125.600	40 B	699,05
150	1,00	32	○ 56000.150.100	150 A	-	-	-	-
150	1,20	32	○ 56000.150.120	150 A	-	-	-	-
150	1,50	32	○ 56000.150.150	150 A	-	-	-	-
150	1,60	32	○ 56000.150.160	150 A	-	-	-	-
150	1,80	32	○ 56000.150.180	128 A	-	-	-	-
150	2,00	32	○ 56000.150.200	128 A	-	-	-	-
150	2,50	32	○ 56000.150.250	128 A	-	-	-	-
150	3,00	32	○ 56000.150.300	128 A	-	-	-	-
150	4,00	32	○ 56000.150.400	100 A	-	-	-	-
160	1,00	32	○ 56000.160.100	160 A	-	-	-	-
160	1,20	32	○ 56000.160.120	160 A	-	-	-	-
160	1,50	32	▲ 56000.160.150	160 A	285,50	-	-	-
160	1,60	32	▲ 56000.160.160	160 A	285,50	-	-	-
160	1,80	32	▲ 56000.160.180	128 A	328,50	-	-	-
160	2,00	32	▲ 56000.160.200	128 A	387,50	-	-	-
160	2,50	32	▲ 56000.160.250	128 A	475,00	-	-	-
160	3,00	32	○ 56000.160.300	128 A	-	-	-	-
160	4,00	32	○ 56000.160.400	128 A	-	-	-	-
200	1,20	32	○ 56000.200.120	200 A	-	-	-	-
200	1,50	32	○ 56000.200.150	160 A	-	-	-	-
200	1,60	32	○ 56000.200.160	160 A	-	-	-	-
200	1,80	32	○ 56000.200.180	160 A	-	-	-	-
200	2,00	32	○ 56000.200.200	160 A	-	-	-	-
200	2,50	32	○ 56000.200.250	160 A	-	-	-	-
200	3,00	32	○ 56000.200.300	128 A	-	-	-	-
200	4,00	32	○ 56000.200.400	128 A	-	-	-	-

1



2



3



4



5



6



7



8



9



10



Art.
100
101
102

Orbitale Rohrkreissägeblätter für: Georg Fischer (GF), Axxair, Protem, Orbitalum
 Orbital pipe cutting circular saw blades for: Georg Fischer (GF), Axxair, Protem, Orbitalum

Art. **5.3980**



HSS-Co5 Cobalt: Zum Sägen von Rohren aus Edelstahl, Stahl, Ne-Metalle

HSS-Co5 Cobalt: For cutting pipes made of stainless steel, steel, non ferrous metals

Art.	Passend für Maschine Suitable for machine					Für Wandstärken For pipe thickness	€
53980.063.010	GF, Axxair, Protem, Orbitalum	● 63	1,6	16	64 BW	1-3 mm	18,75
53980.063.020	GF, Axxair, Protem, Orbitalum	● 63	1,6	16	100 BW	0,6-1,5 mm	18,75
53980.068.010	GF, Axxair, Protem, Orbitalum	● 68	1,6	16	44 BW	2-7 mm	19,50
53980.068.020	GF, Axxair, Protem, Orbitalum	● 68	1,6	16	72 BW	1-3 mm	19,50
53980.080.010	GF, Axxair, Orbitalum	● 80	2,0	16	34 BW	5-12 mm	25,50
53980.080.020	GF, Axxair, Orbitalum	● 80	2,0	16	54 BW	2-7 mm	25,50
53980.080.030	GF, Axxair, Orbitalum	● 80	2,0	16	80 BW	1-3 mm	25,50

Für höchste Standzeiten siehe neue Artikel 5.3965 nächste Seite · For maximum tool life see new article 5.3965 next page.

Art. **5.3990**



HSS-Co5 Cobalt + **Kx beschichtet**: Zum Sägen von Rohren aus Edelstahl, Stahl, Ne-Metalle.

Durch **Kx-Beschichtung** werden höchste Standzeiten erreicht (auch bei nicht optimaler Kühlung)

HSS-Co5 Cobalt + **Kx coating**: For cutting pipes made of stainless steel, steel, non ferrous metals.

By **Kx coating** excellent tool life (even at sub-optimal cooling)

Art.	Passend für Maschine Suitable for machine					Für Wandstärken For pipe thickness	€
53990.063.010	GF, Axxair, Protem, Orbitalum	● 63	1,6	16	64 BW	1-3 mm	24,45
53990.063.020	GF, Axxair, Protem, Orbitalum	● 63	1,6	16	100 BW	0,6-1,5 mm	24,45
53990.068.010	GF, Axxair, Protem, Orbitalum	● 68	1,6	16	44 BW	2-7 mm	25,65
53990.068.020	GF, Axxair, Protem, Orbitalum	● 68	1,6	16	72 BW	1-3 mm	25,65
53990.080.010	GF, Axxair, Orbitalum	● 80	2,0	16	34 BW	5-12 mm	31,95
53990.080.020	GF, Axxair, Orbitalum	● 80	2,0	16	54 BW	2-7 mm	31,95
53990.080.030	GF, Axxair, Orbitalum	● 80	2,0	16	80 BW	1-3 mm	31,95

Für höchste Standzeiten siehe neue Artikel 5.3965 nächste Seite · For maximum tool life see new article 5.3965 next page.

Art. **5.4000**



HSS-DMo5: Zum Sägen von Rohren aus Stahl, Ne-Metalle

HSS-DMo5: For cutting pipes made of steel, non ferrous metals

Art.	Passend für Maschine Suitable for machine					Für Wandstärken For pipe thickness	€
54000.063.010	GF, Orbitalum	▲ 63	1,6	16	44 BW	2-7 mm	14,25
54000.063.020	GF, Orbitalum	▲ 63	1,6	16	80 BW	1-3 mm	14,25
54000.068.010	GF, Orbitalum	▲ 68	1,6	16	44 BW	2-7 mm	15,40

Auslaufartikel! Ersatzartikel siehe oben Artikel 5.3980
 Discontinued! Alternative article see above article 5.3980

Art. **5.4010**



HSS-Co5 Cobalt: Zum Sägen von Rohren aus Edelstahl, Stahl, Ne-Metalle

HSS-Co5 Cobalt: For cutting pipes made of stainless steel, steel, non ferrous metals

Art.	Passend für Maschine Suitable for machine					Für Wandstärken For pipe thickness	€
54010.063.010	GF, Orbitalum	▲ 63	1,6	16	44 BW	2-7 mm	16,75
54010.063.020	GF, Orbitalum	▲ 63	1,6	16	64 BW	1-3 mm	16,75
54010.063.030	GF, Orbitalum	▲ 63	1,2	16	100 BW	0,6-1,5 mm	14,90
54010.068.010	GF, Orbitalum	▲ 68	1,6	16	44 BW	2-7 mm	18,10
54010.068.030	GF, Orbitalum	▲ 68	1,6	16	84 BW	0,8-2,5 mm	18,10
54010.075.010	GF, Orbitalum	▲ 75	2,0	16	32 BW	6-10 mm	21,90

Auslaufartikel! Ersatzartikel siehe oben Artikel 5.3980 / 5.3990
 Discontinued! Alternative article see above article 5.3980 / 5.3990

- 1
- 2
- 3
- 4
- 5
- 6
- 7
- 8
- 9
- 10

Art.
100
101
102

Orbitale Rohrkreissägeblätter für: Georg Fischer (GF), Orbitalum, Exact
 Orbital pipe cutting circular saw blades for: Georg Fischer (GF), Orbitalum, Exact

Art. **5.3950**



Kreissägeblatt **Hartmetall-bestückt** zum Sägen in Rohre aus: **Stahl, Kupfer, Aluminium, Kunststoff**

Carbide tipped circular saws for cutting in pipes made of: **Steel, copper, aluminium, plastics**

Art.	Passend für Maschine Suitable for machine					€
53950.140.010	Georg Fischer (GF) + Orbitalum Scorp 220/360 Exact PC 170, 170E, 220E, 200, 3650	▲ 140	1,8/1,4	62	46 WZ	35,55
53950.140.020	Georg Fischer (GF) + Orbitalum Scorp 220/360 Exact PC 170, 170E, 220E, 200, 3650	● 140	1,8/1,4	62	48 WWF	40,55
53950.165.010	Exact PC 280E, 360E	● 165	1,8/1,4	62	54 WWF	56,45

Orbitale Rohrkreissägeblätter für: Georg Fischer (GF), Orbitalum, Exact
 Orbital pipe cutting circular saw blades for: Georg Fischer (GF), Orbitalum, Exact

Art. **5.3960**



Kreissägeblatt **Cermet (Keramik)** bestückt für **höchste Standzeit**. Zum Sägen in Rohre aus: **Edelstahl, Säurebeständiger Stahl, Stahl, Kupfer, Aluminium, Kunststoff**

Circular saw blades **Cermet (Ceramic)** tipped for **maximum tool life**. For cutting in pipes made of: **Stainless steel, acid-resistant steel, steel, copper, aluminium, plastic**

Art.	Passend für Maschine Suitable for machine					€
53960.140.020	Georg Fischer (GF) + Orbitalum Scorp 220/360 Exact PC 170, 170E, 220E, 200, 3650	● 140	1,8/1,4	62	48 WWF	52,85
53960.165.010	Exact PC 280E, 360E	● 165	1,8/1,4	62	54 WWF	60,95

Orbitale Rohrkreissägeblätter für: Axxair, Georg Fischer (GF), Protrem, Orbitalum
 Orbital pipe cutting circular saw blades for: Axxair, Georg Fischer (GF), Protrem, Orbitalum

Art. **5.3965**



Kreissägeblatt **Cermet (Keramik)** bestückt für **höchste Standzeit**. Zum Sägen in Rohre aus: **Edelstahl, Säurebeständiger Stahl, Stahl, Kupfer, Aluminium, Kunststoff**

Circular saw blades **Cermet (Ceramic)** tipped for **maximum tool life**. For cutting in pipes made of: **Stainless steel, acid-resistant steel, steel, copper, aluminium, plastic**

Art.	Passend für Maschine Suitable for machine					Hinweis Comment	€
53965.063.010	Axxair, GF, Protrem, Orbitalum	● 63	2,0/1,6	16	28 BW	Für Stahl, Ne-Metalle, Kunststoffe mit Wandstärke 2-7 mm For steel, non ferrous metals, plastics with wall thickness 2-7 mm	36,85
53965.063.020	Axxair, GF, Protrem, Orbitalum	● 63	1,8/1,4	16	32 BW	Für alle oben genannten Materialien mit Wandstärke 1-3 mm For all above mentioned materials with wall thickness 1-3 mm	38,45
53965.068.010	Axxair, GF, Protrem, Orbitalum	● 68	2,0/1,6	16	28 BW	Für Stahl, Ne-Metalle, Kunststoffe mit Wandstärke 2-7 mm For steel, non ferrous metals, plastics with wall thickness 2-7 mm	37,15
53965.068.020	Axxair, GF, Protrem, Orbitalum	● 68	1,8/1,4	16	32 BW	Für alle oben genannten Materialien mit Wandstärke 1-3 mm For all above mentioned materials with wall thickness 1-3 mm	38,75
53965.090.010	Axxair, GF, Protrem, Orbitalum	● 90	2,2/1,8	16	28 BW	Für Stahl, Ne-Metalle, Kunststoffe mit Wandstärke 2-7 mm For steel, non ferrous metals, plastics with wall thickness 2-7 mm	40,05
53965.090.020	Axxair, GF, Protrem, Orbitalum	● 90	2,0/1,6	16	36 BW	Für alle oben genannten Materialien mit Wandstärke 1-3 mm For all above mentioned materials with wall thickness 1-3 mm	43,25
53965.125.010	Axxair, GF, Protrem, Orbitalum	● 125	1,5/1,2	16	52 BW	Für alle oben genannten Materialien mit Wandstärke 1-3 mm For all above mentioned materials with wall thickness 1-3 mm	59,25

Diamantbestreutes Blatt: Georg Fischer (GF), Orbitalum, Exact
 Diamond grit blade: Georg Fischer (GF), Orbitalum, Exact

Art. **5.3970**



Diamantbestreutes Blatt zum Trennen von Rohre aus: **Gusseisen, Sphäroguss (GGG), Gusseisen mit Betonschicht, Glasfaser (GFK), Kohlefaser (CFK)**

Diamond-Grit circular saw blades for cutting in pipes made of: **Cast iron, Ductile cast iron (GGG), Cast iron with layer of concrete, fiber glass (FRP), carbon fiber (CFRP)**

Art.	Passend für Maschine Suitable for machine					€
53970.140.010	Georg Fischer (GF) + Orbitalum Scorp 220/360 Exact PC 170, 170E, 220E, 200, 3650	● 140	2,7/1,5	62		55,45
53970.165.010	Exact PC 280E, 360E	● 165	2,7/1,5	62		67,00

- 1
- 2
- 3
- 4
- 5
- 6
- 7
- 8
- 9
- 10

Art.
100
101
102

Art. **5.6100**

"Vorderseitige Aufspannung"
Circular saw blade retainer – front side securing

HSS

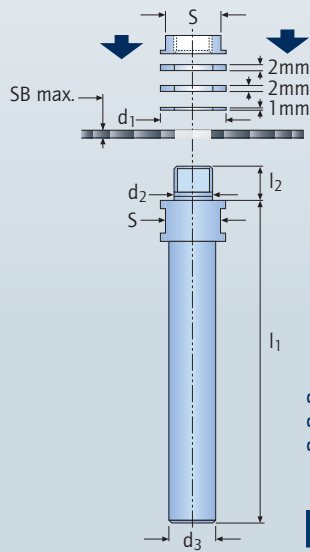

d2 = Sägeblattbohrung / Saw blade bore
d1 = Flanschdurchmesser / Flange diameter
d3 = Schaftdurchmesser / Shank diameter

Art.	d2 h6	d3 h6	d1	l1	l2	SB max.	S	€
56100.03.05	• 3	5	5	60	8,0	3	4	71,75
56100.05.06	• 5	6	10	70	10,0	6	8	71,75
56100.05.06.075	• 5	6	7,5	70	7,0	3	6	71,75
56100.05.10	• 5	10	10	80	10,0	6	8	71,75
56100.06.10	• 6	10	12	80	10,5	6	10	78,65
56100.08.10	• 8	10	15	80	10,0	6	13	82,25
56100.08.12	• 8	12	15	90	11,0	6	13	82,25
56100.10.06	• 10	6	18	80	10,5	6	15	85,25
56100.10.10	• 10	10	18	80	10,5	6	15	85,25
56100.10.16	• 10	16	18	100	11,5	6	15	85,25
56100.13.16	• 13	16	22	110	12,0	6	19	95,75
56100.16.10	• 16	10	22	80	8,0	3	19	110,15
56100.16.20	• 16	20	26	120	13,0	6	22	110,15
56100.22.16	• 22	16	32	120	13,0	6	27	110,15

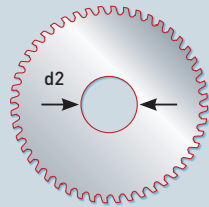
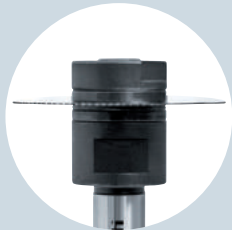

Art. **5.6101**

"Rückseitige Aufspannung" · Circular saw blade retainer – rear side securing

HSS

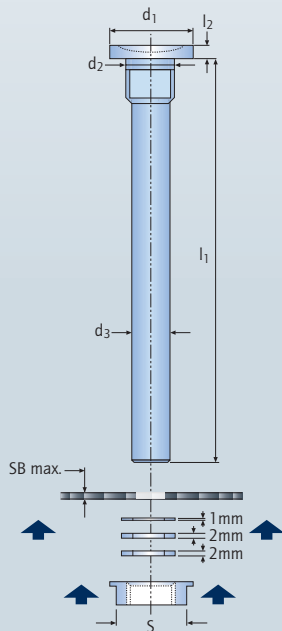

d2 = Sägeblattbohrung / Saw blade bore
d1 = Flanschdurchmesser / Flange diameter
d3 = Schaftdurchmesser / Shank diameter

Art.	d2 h6	d3 h6	d1	l1	l2	SB max.	S	€
56101.05.04	• 5	4	10	50	2,0	6	8	71,75
56101.06.05	• 6	5	12	60	2,0	6	10	78,65
56101.08.06	• 8	6	15	70	2,0	6	13	82,25
56101.08.07	• 8	7	15	80	2,0	6	13	82,25
56101.10.06	• 10	6	18	70	2,5	6	15	85,25
56101.10.08	• 10	8	18	90	2,5	6	15	85,25
56101.13.10	• 13	10	22	110	2,5	6	19	95,75
56101.16.12	• 16	12	26	120	2,5	6	22	110,15

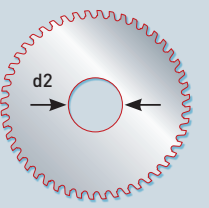
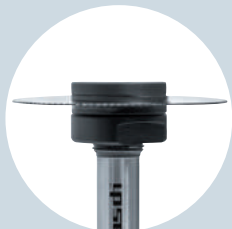

- 1
- 2
- 3
- 4
- 5
- 6
- 7
- 8
- 9
- 10

Art.
100
101
102

Reduzierringe, geschliffen, außen gerändelt, Passung H7
Reduction rings, ground, knurled outward, H7 fit

Art. 11.1630

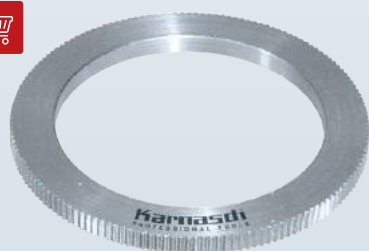

Ø Außen Outer	Ø Innen Inner	Stärke Strength	ART. 11.1630	€	Ø Außen Outer	Ø Innen Inner	Stärke Strength	ART. 11.1630	€	Ø Außen Outer	Ø Innen Inner	Stärke Strength	ART. 11.1630	€
16	12,7	1,6	111630.005	1,75	30	18	1,4	111630.205	1,95	32	30	1,6	111630.385	2,10
16	13	1,5	111630.010	1,75	30	18	1,8	111630.210	1,95	32	30	1,8	111630.390	2,10
18	16	1,4	111630.015	1,75	30	20	1,4	111630.215	1,95	32	30	2,0	111630.395	2,10
18	16	1,6	111630.020	1,75	30	20	1,6	111630.220	1,95	32	30	2,2	111630.400	2,10
20	10	1,4	111630.025	1,75	30	20	1,8	111630.225	1,95	32	30	2,5	111630.405	2,10
20	12,7	1,4	111630.030	1,75	30	20	2,0	111630.230	1,95	32	30	3,5	111630.410	2,10
20	12,7	1,6	111630.035	1,75	30	20	2,2	111630.235	1,95	35	20	2,0	111630.415	2,10
20	13	1,4	111630.040	1,75	30	20	2,5	111630.240	1,95	35	20	2,2	111630.420	2,10
20	13	1,6	111630.045	1,75	30	20	2,8	111630.245	1,95	35	20	2,5	111630.425	2,10
20	13	1,8	111630.050	1,75	30	22	1,4	111630.250	1,95	35	20	2,8	111630.430	2,10
20	15	1,6	111630.055	1,75	30	22	1,8	111630.255	1,95	35	25	2,2	111630.435	2,10
20	16	1,4	111630.060	1,75	30	22	2,0	111630.260	1,95	35	25	2,5	111630.440	2,10
20	16	1,6	111630.065	1,75	30	22	2,2	111630.265	1,95	35	25	2,8	111630.445	2,10
20	16	1,8	111630.070	1,75	30	22,23	1,4	111630.270	1,95	35	30	1,8	111630.450	2,10
20	16	2,0	111630.075	1,75	30	22,23	1,6	111630.275	1,95	35	30	2,0	111630.455	2,10
20	16	2,2	111630.080	1,75	30	22,23	1,8	111630.280	1,95	35	30	2,2	111630.460	2,10
20	16	2,6	111630.085	1,75	30	22,23	2,2	111630.285	1,95	35	30	2,5	111630.465	2,10
20	18	1,4	111630.090	1,75	30	22,23	2,5	111630.290	1,95	35	30	2,8	111630.470	2,10
22	20	1,4	111630.095	1,95	30	25	1,4	111630.295	1,95	35	32	1,8	111630.475	2,10
22	20	1,6	111630.100	1,95	30	25	1,6	111630.300	1,95	40	22	2,5	111630.480	2,50
22	20	1,8	111630.105	1,95	30	25	1,8	111630.305	1,95	40	25	2,8	111630.485	2,50
22	20	2,0	111630.110	1,95	30	25	2,0	111630.310	1,95	40	25,4	2,0	111630.490	2,50
22,23	20	1,4	111630.115	1,95	30	25	2,2	111630.315	1,95	40	30	2,0	111630.495	2,50
22,23	20	1,6	111630.120	1,95	30	25	2,5	111630.320	1,95	40	30	2,2	111630.500	2,50
25	16	1,4	111630.125	1,95	30	25	2,8	111630.325	1,95	40	30	2,5	111630.505	2,50
25	20	1,4	111630.130	1,95	30	25,4	1,4	111630.326	1,95	40	30	2,8	111630.510	2,50
25	20	1,6	111630.135	1,95	30	25,4	1,6	111630.327	1,95	40	32	1,8	111630.515	2,50
25	20	1,8	111630.140	1,95	30	25,4	1,8	111630.328	1,95	40	32	2,0	111630.520	2,50
25	20	2,0	111630.145	1,95	30	25,4	2,0	111630.329	1,95	40	32	2,5	111630.525	2,50
25,4	20	1,4	111630.150	1,95	30	28	2,8	111630.330	1,95	40	32	2,8	111630.530	2,50
25,4	22,23	1,4	111630.155	1,95	30	28	3,0	111630.335	1,95	40	32	3,0	111630.535	2,50
25,4	22,23	1,8	111630.160	1,95	30	28	3,2	111630.340	1,95	40	32	3,2	111630.540	2,50
30	15	1,8	111630.165	1,95	32	20	1,8	111630.345	2,10	40	35	2,8	111630.545	2,50
30	15	2,0	111630.170	1,95	32	20	2,2	111630.350	2,10	40	38	2,8	111630.550	2,50
30	16	1,4	111630.175	1,95	32	22	2,2	111630.355	2,10	40	38	3,0	111630.555	2,50
30	16	1,6	111630.180	1,95	32	22	2,5	111630.360	2,10	50	30	2,5	111630.560	2,95
30	16	1,8	111630.185	1,95	32	25	2,0	111630.365	2,10	50	30	2,8	111630.565	2,95
30	16	2,0	111630.190	1,95	32	25	2,2	111630.370	2,10	50	30	3,0	111630.570	2,95
30	16	2,2	111630.195	1,95	32	25	2,5	111630.375	2,10	50	32	3,0	111630.575	2,95
30	16	2,5	111630.200	1,95	32	25	2,6	111630.380	2,10					

Änderungen

Rework

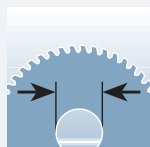

Bohrungen erweitern
Rebore standard bore

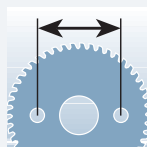

Nebenlöcher
Pin holes

Preise und Lieferzeit auf Anfrage · Prices and delivery time available on request

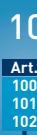

Art.
100
101
102

Art. 11.1621
max. Ø 315 mm

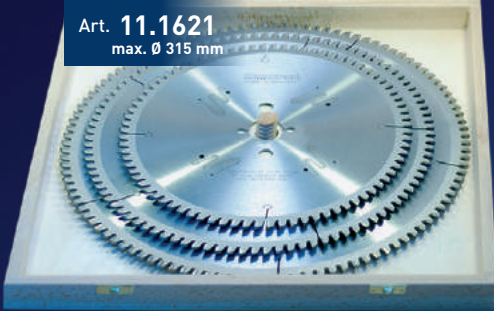

Art. 11.1620
max. Ø 260 mm

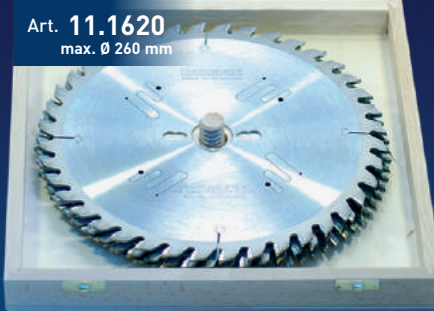

Art. 11.1622
max. Ø 355 mm

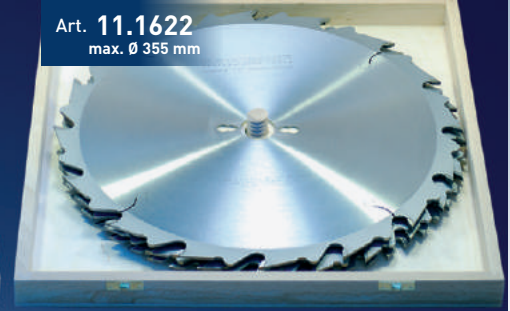

SÄGEN-SETS SAW SETS

Stellen Sie sich Ihr eigenes Aktions-Set im hochwertigen Holzkoffer zusammen. Es passen 3 Blätter bis maximal 355 mm Durchmesser in den Koffer. Wählen Sie selbst aus unserem Gesamtsortiment. Ab 10 Sets mit dem gleichen Inhalt sind Sonderpreise möglich. Sprechen Sie uns an.

Assemble your own action set in a high-quality wood case. 3 blades up to a maximum diameter of 355 mm fit in the case. Select from our entire range. Special prices possible starting at 10 sets with the same content. Contact us about this.

◀ 80 cm ▶

SÄGEN-DISPLAYS SAW DISPLAYS



◀ 2 m ▶

Stellen Sie sich Ihr eigenes Display zusammen. Wählen Sie aus unserem Sortiment aus. Wir machen Ihnen ein Angebot.

Put together your own display. Select from our range. We will make you an offer.

Art.
100
101
102