



# SIMPLY BETTER DRILLING

The latest programme of BDS Maschinen GmbH.  
Magnetic core drilling machines, Annular cutters and Accessories.

Product Overview 2017

# BDS magnetic core drilling machines

Four performance categories in the range.

## ProfiPLUS

Heavy duty magnetic drilling + tapping + countersink + reaming machine. Equipped with oil bath gearbox, full wave control electronics, KEYLESS drill chuck, reversible motor, variable speed & torque controls, intelligent sensors & indicators, etc. With a range of 7 different models to suit your requirements.

## ProfiSTART

Heavy duty magnetic drilling machine. Equipped with intelligent sensors and indicators. With a range of 4 different models to suite your requirements.

## ProfiBASIC

High performance - low price. The economic magnetic drilling machines. Now equipped with attached cooling tank and bigger stronger carry case. With a range of 4 different models to suite your requirements.

## ProfiSPEZIAL

Special purpose drilling machines. Consisting of rail drilling machines, compact magnetic drilling machine, Automatic magnetic drilling machine, Cordless magnetic drilling machine, Pneumatic magnetic drilling machine, etc.



Magnetic core drilling machines from BDS are convincing because of their performance, their features and their safety.

## Timely wear warning!

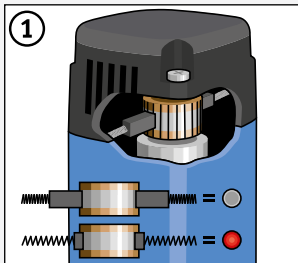

The machines of the Profi-PLUS class are provided with an indicator to visualise & control the wear of the carbon brushes. By replacing the worn carbon brushes in time, you will protect the motor of your machine from damage.

## Covered for more safety!

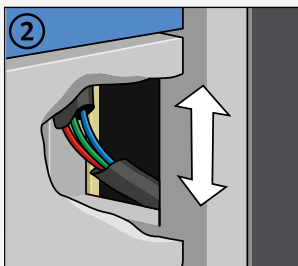

BDS Magnetic Core Drilling Machines are safe to handle. Due to internal cabling, cables are protected against being torn-off.

## Easy to adjust with precision!



You can recognize machines with Swivel Base by this label.

The Swivel Base is an adjustment mechanism on the BDS magnetic core drilling machines to position the machine even under the magnetic condition. To use it: Bring the machine roughly into position, activate the magnet, disable the Swivel Base locking mechanism and now adjust the machine exactly. A relief, especially for overhead or horizontal work.

## High power for a low rotation speed!

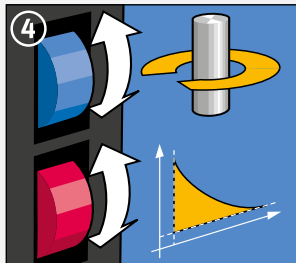

Full wave control electronics enable the motor performance to constantly adapt to the load when drilling.

This feature enables the machine to deliver of high power with a low rotation speed and a steady operating sequence.

If the peak load is too high, the electronic torque shutdown will activate and prevent the tool from breaking.

## No more running dry or overheating.



Thanks to the tool's automatic internal lubrication, the cutting oil is always applied where it is needed. This principle ensures an exact amount and even distribution over the entire cutting area.

The drill doesn't run dry or overheat, and there's no unnecessary use of coolant. This significantly improves tool life and work results.

## For a long service life!

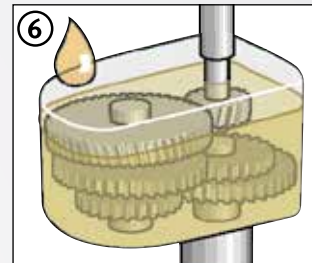

One of the most important and differentiating feature of a BDS magnetic core drilling machine is its gearbox. The BDS machines have multi-stage oil gearbox. An oil gearbox helps in providing lubrication to all the gears uniformly, therefore making the BDS machines more robust and reliable for longer service time.

## Magnet adhesion indicator!

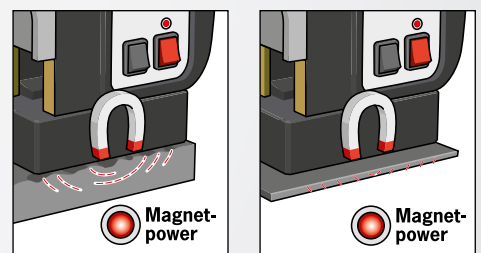
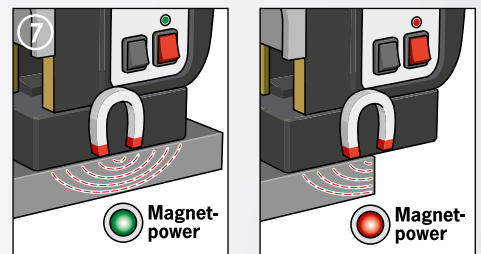

The load configuration and the reserves of the electro-magnet are exactly adapted for the performance of the respective magnetic core drilling machine. The user is informed by an indicator if the magnet is completely clamped or not on the material. LED green: The magnetic adhesion meets the minimum requirements.

LED red: The magnetic adhesion is not sufficient, because it is reduced due to low material thickness or a coat of lacquer, forge scale or zinc.





## BDS Magnetic Core Drilling Machines



Magnetic core drilling machines of the ProfiPLUS series are characterized by the universal range of applications in machinery and plant engineering. As an all-rounder, this series offers the following features:

- Full wave control electronics
- Forward and Reverse operation (CW / CCW)
- Multi-stage gear oil bath gearbox
- Reversible motor

- torque control
- KEYLESS quick-change drill chuck system, and many more. All the magnetic core drilling machines of this category have in common a high degree of flexibility when drilling, reaming, countersinking and thread cutting.



# MAB 485

# MAB 485 SB

## Clamping devices



**Processing channelled and gusset plates.**  
Use the vacuum clamping device ZAV 300 with a high-performance pump for these materials.

### Vacuum clamping device

ZAV 300 – suitable for channelled or gusset plates, non-ferrous metals and stainless steel.



### Vacuum clamping device

ZAV 400 – suitable for smooth surfaces, non-ferrous metals and stainless steel.



### Tube clamping device

ZRO 250 – for tube  $\varnothing$  80 – 250 mm, for MAB 455, MAB 485, MAB 525, MABasic 450  
ZRO 500 – for tube  $\varnothing$  150 bis 500 mm, for MAB 825, MAB 845, MABasic 850

<b>Core drill:</b> $\varnothing$ 40 mm L 30 mm L 55 mm	<b>Twist drilling:</b> $\varnothing$ 18 mm <b>Reaming:</b> $\varnothing$ 18 mm	<b>Countersinking:</b> $\varnothing$ 40 mm <b>Thread cutting:</b> M16

<b>Core drill:</b> $\varnothing$ 40 mm L 30 mm L 55 mm	<b>Twist drilling:</b> $\varnothing$ 18 mm <b>Reaming:</b> $\varnothing$ 18 mm	<b>Countersinking:</b> $\varnothing$ 40 mm <b>Thread cutting:</b> M16

Motor output:	1150 Watt
Voltage:	230 V AC, 50-60 Hz
Stroke:	160 mm
Magnet size:	84 x 168 x 41,5 mm
Weight:	13 kg

Motor output:	1150 Watt
Voltage:	230 V AC, 50-60 Hz
Stroke:	160 mm
Magnet size:	84 x 168 x 41,5 mm
Weight:	13 kg

Quick change drill chuck system:	KEYLESS, 19 mm ( $\frac{3}{4}$ " )
Morse taper:	MT 2
Speed range 1:	50 – 250 min <sup>-1</sup>
Speed range 2:	100 – 450 min <sup>-1</sup>
Permanent internal lubrication:	•
Full wave control electronics:	•
Magnet indicator:	•
Overheating protection:	•
CW/CCW rotation:	•
Carbon brush wear control:	•

Quick change drill chuck system:	KEYLESS, 19 mm ( $\frac{3}{4}$ " )
Morse taper:	MT 2
Speed range 1:	50 – 250 min <sup>-1</sup>
Speed range 2:	100 – 450 min <sup>-1</sup>
Permanent internal lubrication:	•
Full wave control electronics:	•
Magnet indicator:	•
Overheating protection:	•
CW/CCW rotation:	•
Carbon brush wear control:	•
Swivel Base, adjustment feature:	•

MAB 485 230 V

MAB 485 110/125 V

MAB 485 SB 230 V

MAB 485 SB 110/125 V

**Scope of delivery MAB 485 and MAB 485 SB:** 1 Magnetic core drilling machine · 1 Quick change drill chuck system KEYLESS, 19 mm Weldon ( $\frac{3}{4}$ " ) · 1 Tapping adapter ZAG 010, ZAG 012, ZAG 016 · 1 Ejector ZAK 075 +100 · 1 Hard protective case · 1 Safety chain · 1 Drill drift MT 2 · 1 Gear rim drill chuck · 1 - 13 mm · 1 Taper drift MT 2/B16 · 1 Operating manual

## MAB 525



## MAB 525 SB

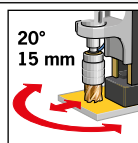

## MAB 825



**Core drill:**  
ø: 50 mm  
L: 30 mm  
L: 55 mm  
L: 75 mm

**Twist drilling:**  
ø: 20 mm  
**Reaming:**  
ø: 20 mm

**Countersinking:**  
ø: 50 mm  
**Thread cutting:**  
ø: M20

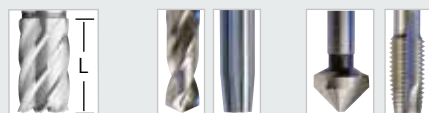

**Core drill:**  
ø: 50 mm  
L: 30 mm  
L: 55 mm  
L: 75 mm

**Twist drilling:**  
ø: 20 mm  
**Reaming:**  
ø: 20 mm

**Countersinking:**  
ø: 50 mm  
**Thread cutting:**  
ø: M20



**Core drill:**  
ø: 100 mm  
L: 30 / 55 mm  
ø: 60 mm  
L: 75 / 110 mm

**Twist drilling:**  
ø: 31,75 mm  
**Reaming:**  
ø: 31,75 mm

**Countersinking:**  
ø: 50 mm  
**Thread cutting:**  
ø: M30

Motor output:	1600 Watt
Voltage:	230 V AC, 50-60 Hz
Stroke:	160 mm
Magnet size:	90 x 180 x 48 mm
Weight:	16 kg

Motor output:	1600 Watt
Voltage:	230 V AC, 50-60 Hz
Stroke:	160 mm
Magnet size:	90 x 180 x 48 mm
Weight:	16 kg

Motor output:	1800 Watt
Voltage:	230 V AC, 50-60 Hz
Stroke:	255 mm
Magnet size:	110 x 220 x 54 mm
Weight:	25 kg

Quick change drill chuck system:	KEYLESS, 19 mm (3/4")
Morse taper:	MT 3
Speed range 1:	70 – 280 min <sup>-1</sup>
Speed range 2:	180 – 580 min <sup>-1</sup>
Permanent internal lubrication:	•
Torque control:	•
Full wave control electronics:	•
Magnet indicator:	•
Overheating protection:	•
CW/CCW rotation:	•
Carbon brush wear control:	•

Quick change drill chuck system:	KEYLESS, 19 mm (3/4")
Morse taper:	MT 3
Speed range 1:	70 – 280 min <sup>-1</sup>
Speed range 2:	180 – 580 min <sup>-1</sup>
Permanent internal lubrication:	•
Torque control:	•
Full wave control electronics:	•
Magnet indicator:	•
Overheating protection:	•
CW/CCW rotation:	•
Carbon brush wear control:	•
Swivel Base, adjustment feature:	•

Quick change drill chuck system:	KEYLESS, 19 mm (3/4")
Industrial arbor:	MT 3, 32 mm (1 1/4")
Morse taper:	MT 3
Speed range 1:	40–110 min <sup>-1</sup>
Speed range 2:	65–175 min <sup>-1</sup>
Speed range 3:	140–360 min <sup>-1</sup>
Speed range 4:	220–600 min <sup>-1</sup>
Friction clutch:	•
Permanent internal lubrication:	•
Torque control:	•
Full wave control electronics:	•
Magnet indicator:	•
Overheating protection:	•
CW/CCW rotation:	•
Carbon brush wear control:	•

MAB 525 230 V

MAB 525 110/125 V

MAB 525 SB 230 V

MAB 525 SB 110/125 V

MAB 825 230 V

MAB 825 110/125 V

**Scope of delivery MAB 525 and MAB 525 SB:** 1 Magnetic core drilling machine · 1 Quick change drill chuck system KEYLESS, 19 mm Weldon (3/4") · 1 Tapping adapter ZGA 010, ZGA 012, ZGA 016 · 1 Ejector ZAK 075, ZAK 090 · 1 Hard protective case · 1 Safety chain · 1 Taper drift MT 3/B16 · 1 Gear rim drill chuck 1 - 13 mm · 1 Drill drift MT 3 · 1 Operating manual



# MAB 845 SB

# MAB 1300

Retooling made easy.



<b>Core drill:</b> ø: 100 mm L: 30 / 55 mm ø: 60 mm L: 75 / 110 mm	<b>Twist drilling:</b> ø: 31,75 mm <b>Reaming:</b> ø: 31,75 mm	<b>Countersinking:</b> ø: 50 mm <b>Thread cutting:</b> ø: M30

<b>Core drill:</b> ø: 130 / 100 mm L: 30 / 55 mm ø: 120 mm L: 75 / 110 mm	<b>Twist drilling:</b> ø: 45 mm <b>Reaming:</b> ø: 50 mm	<b>Countersinking:</b> ø: 80 mm <b>Thread cutting:</b> ø: M42

**Magnetic core drilling with large calibres.**

Up to 130 mm in diameter and up to 110 mm cutting depth.

Motor output:	1800 Watt
Voltage:	230 V AC, 50-60 Hz
Stroke:	255 mm
Magnet size:	110 x 220 x 54 mm
Weight:	25 kg

Motor output:	2300 Watt
Voltage:	230 V AC, 50-60 Hz
Stroke with/without steady:	85 / 310 mm
Magnet size:	120 x 360 x 65 mm
Weight:	51 kg

Quick change drill chuck system:	KEYLESS, 19 mm (3/4")
Industrial arbor:	MT 3, 32 mm (1 1/4")
Morse taper:	MT 3
Speed range 1:	40-110 min <sup>-1</sup>
Speed range 2:	65-175 min <sup>-1</sup>
Speed range 3:	140-360 min <sup>-1</sup>
Speed range 4:	220-600 min <sup>-1</sup>
Friction clutch:	•
Permanent internal lubrication:	•
Torque control:	•
Full wave control electronics:	•
Magnet indicator:	•
Overheating protection:	•
CW/CCW rotation:	•
Carbon brush wear control:	•
Swivel Base, adjustment feature:	•

Direct arbor:	32 mm Weldon (1 1/4")
Morse taper:	MT 4
Speed range 1:	30 - 80 min <sup>-1</sup>
Speed range 2:	50 - 120 min <sup>-1</sup>
Speed range 3:	130 - 350 min <sup>-1</sup>
Speed range 4:	210 - 550 min <sup>-1</sup>
Friction clutch:	•
Permanent internal lubrication:	•
Torque control:	•
Full wave control electronics:	•
Magnet indicator:	•
Overheating protection:	•
CW/CCW rotation:	•
Carbon brush wear control:	•



**Drilling with a twist drill of up to ø 45 mm.**

A flexible choice of tools. Maximum stroke without steady: 310 mm

**Scope of delivery MAB 825, MAB 845 and MAB 845 SB:**

- 1 Magnetic core drilling machine
- 1 Quick change drill chuck system KEYLESS, 19 mm Weldon (3/4")
- 1 Industrial arbor MT3, 32 mm Weldon (1 1/4")
- 1 Ejector ZAK 075, 090, 100, 120
- 1 Carry case on wheels
- 1 Safety chain
- 1 Offset screwdriver SW 6
- 1 Drill drift MT 3
- 1 Operating manual

**Scope of delivery MAB 1300:**

- 1 Magnetic core drilling machine
- 1 Carry case on wheels
- 1 Safety chain
- 1 Offset screwdriver SW 4, 6, 8
- 1 Ejector ZAK 075, 090, 100, 120
- 1 Drill drift MT 4
- 1 Bushing ZAP 200 from Weldon 32 mm to 19 mm
- 1 Operating manual

MAB 845 SB 230 V

MAB 845 SB 110/125 V

MAB 1300 230 V

MAB 1300 110/125 V

## MAB 100 K

NEW



**Core drill:**  
 ø: 30 mm  
 L: 30 mm  
 L: 55 mm

Motor output:	1050 Watt
Voltage:	230 V AC, 50-60 Hz
Stroke:	70 mm
Magnet size:	80 x 160 x 41,5 mm
Weight:	9,9 kg

Direct arbor:	KEYLESS, 19 mm ( $\frac{3}{4}$ " )
Speed range 1:	460 min <sup>-1</sup>
Permanent internal lubrication:	•

MAB 100 230 V

MAB 100 110/125 V

## BDS Magnetic Core Drilling Machines



The best entry into a successful technology: The professional user can expect well-engineered, robust machines built for continuous service.

Satisfy yourself as to the BDS quality 'Made in Germany'.

Heavy duty oil bath gearbox machines equipped with intelligent sensors and indicators.

**Scope of delivery MAB 100:** 1 Magnetic core drilling machine · 1 Ejector ZAK 075 +100 · 1 Hard protective case · 1 Safety chain · 1 Offset screwdriver SW 4 · 1 Operating manual



# MAB 455





# MAB 455 SB



# MAB 465



	
<b>Core drill:</b> ø: 40 mm L: 30 mm L: 55 mm	<b>Twist drilling:</b> ø: 18 mm

	
<b>Core drill:</b> ø: 40 mm L: 30 mm L: 55 mm	<b>Twist drilling:</b> ø: 18 mm

			
<b>Core drill:</b> ø: 40 mm L: 30 mm L: 55 mm	<b>Twist drilling:</b> ø: 16 mm	<b>Countersinking:</b> ø: 40 mm	<b>Thread cutting:</b> ø: M16

Motor output:	1150 Watt
Voltage:	230 V AC, 50-60 Hz
Stroke:	160 mm
Magnet size:	84 x 168 x 41,5 mm
Weight:	13 kg

Motor output:	1150 Watt
Voltage:	230 V AC, 50-60 Hz
Stroke:	160 mm
Magnet size:	84 x 168 x 41,5 mm
Weight:	13 kg

Motor output:	1150 Watt
Voltage:	230 VAC, 50-60 Hz
Stroke:	160 mm
Magnet size:	84 x 168 x 41,5 mm
Weight:	13 kg

Quick change drill chuck system:	KEYLESS, 19 mm ( $\frac{3}{4}$ " )
Morse taper:	MT 2
Speed range 1:	250 min <sup>-1</sup>
Speed range 2:	450 min <sup>-1</sup>
Permanent internal lubrication:	•
Magnet indicator:	•

Quick change drill chuck system:	KEYLESS, 19 mm ( $\frac{3}{4}$ " )
Morse taper:	MT 2
Speed range 1:	250 min <sup>-1</sup>
Speed range 2:	450 min <sup>-1</sup>
Permanent internal lubrication:	•
Magnet indicator:	•
Swivel Base, adjustment feature:	•

Direct arbor:	19 mm Weldon ( $\frac{3}{4}$ " )
Speed range 1:	50-250 min <sup>-1</sup>
Speed range 2:	100-450 min <sup>-1</sup>
Permanent internal lubrication:	•
Full wave control electronics:	•
Magnet indicator:	•
Overheating protection:	•
CW/CCW rotation:	•

MAB 455 230 V

MAB 455 110/125 V

MAB 455 SB 230 V

MAB 455 SB 110/125 V

MAB 465 230 V

MAB 465 110/125 V

**Scope of delivery MAB 455 and MAB 455 SB:** 1 Magnetic core drilling machine · 1 Quick change drill chuck system KEYLESS, 19 mm Weldon ( $\frac{3}{4}$ " ) · 1 Ejector ZAK 075 +100 · 1 Hard protective case · 1 Safety chain · 1 Drill drift MT 2 · 1 Operating manual

**Scope of delivery MAB 465:** Machine MAB 465, Hexagonal offset screwdrive, size SW 4, ZAK 075 ejector pin, ZAK 100 ejector pin, Safety chain Transport case (not illustrated) Operating instructions



# MABasic 200



<b>Core drill:</b>	<b>Twist drilling:</b>
ø: 32 mm	ø: 13 mm
L: 30 mm	
L: 55 mm	

Motor output:	900 Watt
Voltage:	230 V AC, 50-60 Hz
Stroke:	160 mm
Magnet size:	84 x 168 x 41,5 mm
Weight:	12 kg

Direct arbor:	19 mm Weldon (3/4")
Speed range 1:	450 min <sup>-1</sup>
Permanent internal lubrication with integrated reservoir:	<input checked="" type="checkbox"/>

- MABasic 200 230 V
- MABasic 200 110/125 V

## BDS Economic Magnetic Core Drilling Machines



High performance - low price. With this new machine concept, BDS Maschinen fill a gap for professional users who cannot compromise on the quality or performance of their machines, but who are able to forgo comfort and fittings for the benefit of good prices.

**New: Integrated reservoir for cutting oil and lubricant for all machines of the ProfibASIC series.**





## MABasic 400



## MABasic 450



## MABasic 850



**Core drill:**  
 ø: 35 mm  
 L: 30 mm  
 L: 55 mm

**Twist drilling:**  
 ø: 16 mm



**Core drill:**  
 ø: 40 mm  
 L: 30 mm  
 L: 55 mm

**Twist drilling:**  
 ø: 18 mm



**Core drill:**  
 ø: 75 mm  
 L: 30 mm  
 L: 55 mm  
 L: 75 mm  
 L: 110 mm

**Twist drilling:**  
 ø: 31,75 mm

Motor output:	1050 Watt
Voltage:	230 V AC, 50-60 Hz
Stroke:	160 mm
Magnet size:	84 x 168 x 41,5 mm
Weight:	12 kg

Motor output:	1150 Watt
Voltage:	230 V AC, 50-60 Hz
Stroke:	160 mm
Magnet size:	84 x 168 x 41,5 mm
Weight:	13 kg

Motor output:	1700 Watt
Voltage:	230 V AC, 50-60 Hz
Stroke:	255 mm
Magnet size:	110 x 220 x 54 mm
Weight:	24 kg

Direct arbor:	19 mm Weldon (3/4")
Speed range 1:	430 min <sup>-1</sup>
Speed range 2:	760 min <sup>-1</sup>
Permanent internal lubrication with integrated reservoir:	•

Industrial arbor:	MT 2, 19 mm Weldon (3/4")
Speed range 1:	250 min <sup>-1</sup>
Speed range 2:	450 min <sup>-1</sup>
Permanent internal lubrication with integrated reservoir:	•

Industrial arbor:	MT 3, 19 mm Weldon (3/4")
Speed range 1:	110 min <sup>-1</sup>
Speed range 2:	175 min <sup>-1</sup>
Speed range 3:	245 min <sup>-1</sup>
Speed range 4:	385 min <sup>-1</sup>
Permanent internal lubrication with integrated reservoir:	•

MABasic 400 230 V

MABasic 400 110/125 V

MABasic 450 230 V

MABasic 450 110/125 V

MABasic 850 230 V

MABasic 850 110/125 V

**Scope of delivery:** 1 Magnetic core drilling machine - 1 Ejector pin ZAK 075 - 1 Plastic carry case - 1 Safety lashing strap - 1 Operating manual. **Additional scope of delivery MABasic 200:** 1 Hexagon offset screwdriver SW 4. **Additional scope of delivery MABasic 450:** 1 Hexagon offset screwdriver SW 5 - 1 Industrial arbor ZIA 219 KN - 1 Drill drift MT 2. **Additional scope of delivery MABasic 850:** 1 Hexagon offset screwdriver SW 5 and SW 6 - 1 Industrial arbor ZIA 332 KN - 1 Drill drift MT 3



## BDS Special Purpose Drilling Machines



Special magnetic core drilling machines assist with specific tasks:

- Use in very tight drilling situations
- Drill with compressed air
- Drill rail profiles with electricity or gas drive

Do you have specific requirements? BDS also delivers special out-of-series solutions.

## MAB 155

NEW



**Core drill:**  
 ø: 35 mm  
 L: 30 mm

Motor output:	1050 Watt
Voltage:	230 V AC, 50-60 Hz
Stroke:	39 mm
Magnet size:	80 x 160 x 36,5 mm
Weight:	11 kg

Direct arbor:	19 mm Weldon (3/4")
Speed range 1:	460 min <sup>-1</sup>

MAB 155 230 V

MAB 155 110/125 V

## AutoMAB 350

NEW



With Automatic Feed & Reverse



**Core drill:**  
 ø: 35 mm  
 L: 30 mm  
 L: 55 mm

Motor output:	1050 Watt
Voltage:	230 V AC, 50-60 Hz
Stroke:	150 mm
Magnet size:	168 x 84 x 41,5 mm
Weight:	15 kg

Direct arbor:	19 mm Weldon (3/4")
Speed range 1:	460 min <sup>-1</sup>
Permanent internal lubrication:	•
Feed	Automatic feed & reverse
LED Load indicators:	•
Magnet with safety switch off:	•

AutoMAB 350 230 V

AutoMAB 350 110/125 V

**Scope of delivery AutoMAB 350:** 1 Magnetic core drilling machine · 1 Ejector ZAK 075+100 · 1 Hard protective case · 1 Safety chain · 1 Offset screwdriver SW 4 · 1 Safety chain · Operating manual

## AutoMAB 450

NEW



With Automatic Feed & Reverse



**Core drill:**  
 ø: 45 mm  
 L: 30 mm  
 L: 55 mm

Motor output:	1150 Watt
Voltage:	230 VAC, 50 – 60 Hz
Stroke:	150 mm
Magnet size:	168 x 84 x 41,5 mm
Weight:	16 kg

Industrial arbor:	MT 2, 19 mm Weldon (3/4")
Speed range 1:	250 min <sup>-1</sup>
Speed range 2:	450 min <sup>-1</sup>
Permanent internal lubrication:	•
Feed	Automatic feed & reverse
LED Load indicators:	•
Magnet with safety switch off:	•

AutoMAB 450 230 V

AutoMAB 450 110/120 V

**Scope of delivery AutoMAB 450:** AutoMAB 450 core drilling machine, Safety chain, ZAK 075 ejector pin, ZAK 100 ejector pin, Hexagonal offset screwdriver Size SW5, Weldon MK2/19 mm industrial holder ZIA 219 KN, Transport case, Operating instructions



## MAB 1300 V



**NEW**

With Automatic Feed & Reverse



**Core drill:**

ø: 130 / 100 mm  
L: 30 / 55 mm  
ø: 120 mm  
L: 75 / 110 mm



**Twist drilling:**

ø: 45 mm  
**Reaming:**  
ø: 50 mm



**Countersinking:**

ø: 80 mm  
**Thread cutting:**  
ø: M42

Motor output:	2300 Watt
Voltage:	230 V AC, 50-60 Hz
Stroke:	310 mm
Magnet size:	120 x 360 x 65 mm
Weight:	51 kg

Direct arbor:	32 mm Weldon (1 1/4")
Morse taper:	MK 4
Speed range 1:	30 – 80 min <sup>-1</sup>
Speed range 2:	50 – 120 min <sup>-1</sup>
Speed range 3:	130 – 350 min <sup>-1</sup>
Speed range 4:	210 – 550 min <sup>-1</sup>

Friction clutch	•
Permanent internal lubrication	•
Torque control	•
Full wave control electronics	•
Magnet indicator	•
Overheating protection	•
CW/CCW rotation	•
Carbon brush wear control	•
Feed:	Automatic Variable Feed

MAB 1300 V 230 V

MAB 1300 V 110/125 V

## MAB 825 KTS



**NEW**

With cross table base X 110 mm Y 120 mm



**Core drill:**

ø: 80 mm  
L: 30 / 55 mm



**Twist drilling:**

ø: 31,75 mm  
**Reaming:**  
ø: 31,75 mm

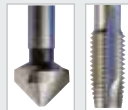

**Countersinking:**

ø: 50 mm  
**Thread cutting:**  
ø: M30

Motor output:	1800 Watt
Voltage:	230 V AC, 50-60 Hz
Stroke:	255 mm
Magnet size:	220 x 220 x 54 mm
Weight:	57,5 kg

Industrial arbor:	MK 3, 19 mm (3/4")
Industrial arbor:	MK 3, 32 mm (1 1/4")
Morse taper:	MK 3
Speed range 1:	40–110 min <sup>-1</sup>
Speed range 2:	65–175 min <sup>-1</sup>
Speed range 3:	140–360 min <sup>-1</sup>
Speed range 4:	220–600 min <sup>-1</sup>

Torque control	•
Full wave control electronics	•
Overheating protection	•
CW/CCW rotation	•
Friction clutch	•
Carbon brush wear control	•
Magnet indicator	•
Permanent internal lubrication	•

MAB 825 KTS 230 V

MAB 825 KTS 110/125 V

Collet chuck

ZSF 316, MK 3, 2 – 16 mm

## AirMAB 5000



**Core drill:**

ø: 35 mm  
L: 30 mm  
L: 55 mm



**Twist drilling:**

ø: 23 mm

Motor approved according to EX class – Ex II 2G T4 IIC D110° C

Motor output:	830 Watt
Nominal torque:	27 Nm
Air consumption:	1.000 l/min
Stroke:	160 mm
Magnet size:	90 x 160 x 60 mm
Weight:	17,5 kg

Quick change drill chuck system: KEYLESS, 19 mm (3/4")

Morse taper:	MK 2
Speed range 1:	min 290 min <sup>-1</sup>
	max 575 min <sup>-1</sup>

Permanent internal lubrication •

### AirMAB 5000

**Scope of delivery MAB 1300 V:** 1 Magnetic core drilling machine · 1 Ejector ZAK 075 + 090 + 100 + 120 · 1 Carry case · 1 Safety strap · 1 Drill drift MK 4 · 1 Quick change drill chuck system MK 4 19 mm Weldon (3/4") · 1 Industrial arbor MK 4 32 mm Weldon (1 1/4") · 1 Torx screwdriver SW 6 + SW 8 · 1 Operating manual

**Scope of delivery MAB 825 KTS:** 1 Magnetic core drilling machine · 1 Ejector ZAK 075 + 090 + 100 + 120 · 1 Carry case · 1 Safety chain · 1 Drill drift MK 3 · 1 Quick change drill chuck system MK 3 19 mm Weldon (3/4") · 1 Industrial arbor MK 3 32 mm Weldon (1 1/4") · 1 Torx screwdriver SW 5 + SW 6 · 1 Operating manual

**Scope of delivery AirMAB 5000:** 1 Magnetic core drilling machine · 1 Quick change drill chuck system KEYLESS, 19 mm Weldon (3/4") · 1 Ejector ZAK 075 + 100 · 1 Hard protective case · 1 Safety chain · 1 Drill drift MK 2 · 1 Operating manual

## BDS rail core drilling machines



RailMAB 965 with petrol engine

### RailMAB 925 with electric motor and

### RailMAB 960 with HONDA petrol engine –

Both systems are easily fixed to the rails with a rapid clamping system. The multitude of optionally available drill adapters greatly increases the flexibility and the ease of use of the two core drilling machines. The track construction machine range is topped off with the BDS special drills of the carbide RAIL series, which have a cutting depth of 30 mm and a diameter of 16 mm to 36 mm. The drill on both machines is lubricated and cooled through an external attachable high-pressure storage tank. Use the cooling lubricant concentrate BDS 6000 to cool and lubricate the machine.



## RailMAB 925



### Core drill: Carbide RAIL

ø: 36 mm  
L: 30 mm  
L: 55 mm

Motor output:	1600 Watt
Voltage:	230 V AC, 50-60 Hz
Stroke:	160 mm
Weight:	17 kg

Quick change drill chuck system: KEYLESS, 19 mm ( $\frac{3}{4}$ " )	
Morse taper:	MT 3
Speed range 1:	70 – 280 min <sup>-1</sup>
Speed range 2:	180 – 580 min <sup>-1</sup>
Permanent internal lubrication:	●
Cooling:	With drilling emulsion
Torque control:	●
Full wave control electronics:	●
Overheating protection:	●
Carbon brush wear control:	●

RailMAB 925 230 V

RailMAB 925 110/125 V

## RailMAB 965



### Core drill: Carbide RAIL

ø: 36 mm  
L: 30 mm

Motor output:	1,5 KW
Motor:	Honda GXH 50
Cubic capacity:	49,4 ccm
Torque:	3,04 Nm
Stroke:	40 mm
Weight:	21,5 kg

Direct arbor:	19 mm Weldon ( $\frac{3}{4}$ " )
Speed range 1:	min 150 min <sup>-1</sup>
	max 225 min <sup>-1</sup>
Permanent internal lubrication:	●
Cooling:	With drilling emulsion

RailMAB 965

**Scope of delivery RailMAB 925:** 1 Rail core drilling machine · 1 High-pressure tank, 5 litres · 1 Reversing ratchet · 1 Rail adapter of your choice (no special version) · 1 Quick change drill chuck system KEYLESS, 19 mm Weldon ( $\frac{3}{4}$ " ) · 1 Offset screwdriver SW 6 · 1 Ejector ZAK 075+100 · 1 Drill drift MT 3 · 1 Carry case · 1 Operating manual

**Scope of delivery RailMAB 960:** 1 Rail core drilling machine · 1 High-pressure tank, 5 litres · 1 Rail adapter of your choice (no special version) · 1 Offset screwdriver SW 4 + 5 + 6 · 1 Ejector ZAK 075 · 1 Carry case · 1 Operating manual

# Compare for yourselves



		ProfiPLUS						ProfiSTART					
		MAB 485	MAB 485 Swivel Base	MAB 525	MAB 525 Swivel Base	MAB 825	MAB 845 Swivel Base	MAB 1300	MAB 100 K <small>NEW</small>	MAB 455 Swivel Base	MAB 455	MAB 465	
	Motor output	Watt	1.150	1.150	1.600	1.600	1.800	1.800	2.300	1.050	1.150	1.150	1.050
	Voltage												
	230 V AC, 50 – 60 Hz		✓	✓	✓	✓	✓	✓	✓	✓	✓	✓	✓
	110/125 V, 50 – 60 Hz		✓	✓	✓	✓	✓	✓	upon request	✓	✓	✓	✓
	36 V · 6 Ah												
	Petrol engine												
	Air consumption	l/min											
	Stroke	mm	160	160	160	160	255	255	85 / 310	70	160	160	160
	Swivel Base – adjustment feature			✓		✓		✓			✓		
	Magnet size	L x B x H											
	80 x 60 x 41,5	mm								✓			
	80 x 160 x 36,5	mm											
	84 x 168 x 41,5	mm	✓	✓							✓	✓	✓
	90 x 180 x 48	mm			✓	✓							
	90 x 190 x 60	mm											
	110 x 220 x 54	mm					✓	✓					
	120 x 360 x 67	mm							✓				
	220 x 220 x 54	mm											
	Weight	kg	13	13	16	16	25	25	51	9,9	13	13	13
	Arbor												
	Direkt 19 mm Weldon 3/4"												✓
	Direkt 32 mm Weldon 1 1/4"								✓				
	Industrial 19 mm Weldon 3/4"												
	Industrial 32 mm Weldon 1 1/4"						✓	✓					
	Quick change drill chuck system												
	KEYLESS 19 mm Weldon 1 3/4"		✓	✓	✓	✓	✓	✓		✓	✓	✓	
	Morse taper MK 2		✓	✓							✓	✓	
	Morse taper MK 3				✓	✓	✓	✓					
	Morse taper MK 4								✓				
	Speed range 1	min <sup>-1</sup>	50 – 250	50 – 250	70 – 280	70 – 280	40 – 110	40 – 110	30 – 80	460	250	250	50 – 250
	Speed range 2	min <sup>-1</sup>	100 – 450	100 – 450	180 – 580	180 – 580	65 – 175	65 – 175	50 – 120		450	450	100 – 450
	Speed range 3	min <sup>-1</sup>					40 – 360	140 – 360	130 – 350				
	Speed range 4	min <sup>-1</sup>					220 – 600	220 – 600	210 – 550				
	Permanent internal lubrication		✓	✓	✓	✓	✓	✓	✓	✓	✓	✓	✓
	Friction clutch						✓	✓	✓				
	Torque control				✓	✓	✓	✓	✓				
	Full wave control electronics		✓	✓	✓	✓	✓	✓	✓				✓
	Magnet indicator		✓	✓	✓	✓	✓	✓	✓		✓	✓	✓
	Overheating protection		✓	✓	✓	✓	✓	✓	✓				✓
	CW/CCW rotation		✓	✓	✓	✓	✓	✓	✓				✓
	Carbon brush wear control		✓	✓	✓	✓	✓	✓	✓				
	Core drill												
	short 30 mm	ø mm	12 – 40	12 – 40	12 – 50	12 – 50	12 – 100	12 – 100	12 – 130	12 – 30	12 – 40	12 – 40	12 – 40
	short 30 mm HKK-R	ø mm											
	long 55 mm	ø mm	12 – 40	12 – 40	12 – 50	12 – 50	12 – 100	12 – 100	12 – 100		12 – 40	12 – 40	12 – 40
	overlong 75 mm	ø mm			18 – 50	18 – 50	18 – 60	18 – 60	18 – 120				
	extra-long 110 mm	ø mm					20 – 60	20 – 60	20 – 120				
	Twist drilling	≤ ø mm	18	18	20	20	31,75	31,75	45		18	18	16
	Reaming	≤ ø mm	18	18	20	20	31,75	31,75	50				
	Countersinking	≤ ø mm	40	40	50	50	50	50	80				40
	Thread cutting	≤ M	16	16	20	20	30	30	42				16



MABasic 200	MABasic 400	MABasic 450	MABasic 850 <span>NEW</span>	MAB 155 <span>NEW</span>	AutoMAB 350 <span>NEW</span>	AutoMAB 450 <span>NEW</span>	MAB 825 KTS <span>NEW</span>	MAB 1300 V <span>NEW</span>	AirMAB 5000	RailMAB 925	RailMAB 965
900	1.050	1.150	1.700	1.050	1.050	1.150	1.800	2.300	830	1.600	
✓	✓	✓	✓	✓	✓	✓	✓	✓		✓	
✓	✓	✓	✓	✓	✓	✓	✓	upon request		✓	
											1,5
									1.000		
160	160	160	255	39	150	150	255	310	160	125	40
				✓							
✓	✓	✓			✓	✓					
			✓						✓		
								✓			
12	12	13	24	11	15	16	57,5	51	17,5	17	21,5
✓	✓			✓	✓						✓
		✓				✓	✓	✓			
			✓				✓	✓			
									✓	✓	
		✓							✓		
			✓				✓	✓		✓	
450	430	250	110	460	460	250	40 – 110	30 – 80	≥290/≤575	70 – 280	≥150/≤225
	760	450	175			450	65 – 175	50 – 120			180 – 580
			245				140 – 360	130 – 350			
			385				220 – 600	210 – 550			
✓	✓	✓	✓		✓	✓	✓	✓	✓	✓	✓
							✓	✓		✓	
							✓	✓		✓	
							✓	✓		✓	
					✓	✓	✓	✓		✓	
							✓	✓		✓	
							✓	✓		✓	
							✓	✓		✓	
							✓	✓		✓	
12 – 32	12 – 35	12 – 40	12 – 75	12 – 35	12 – 35	12 – 45	12 – 80	12 – 130	12 – 35		
										17 – 36	17 – 36
12 – 32	12 – 35	12 – 40	12 – 75		12 – 35	12 – 45	12 – 80	12 – 120	12 – 35	17 – 36	
			12 – 75					18 – 120			
			12 – 75					20 – 120			
13	16	18	31,75		13	18	31,75	45	23		
							31,75	50			
							50	80			
							30	42			

# Technical drawings

MAB Magnetic core drilling machines.

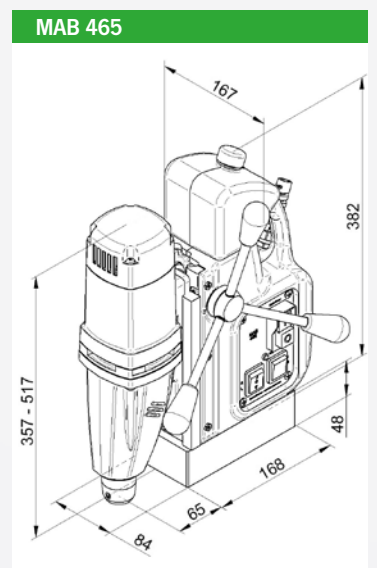
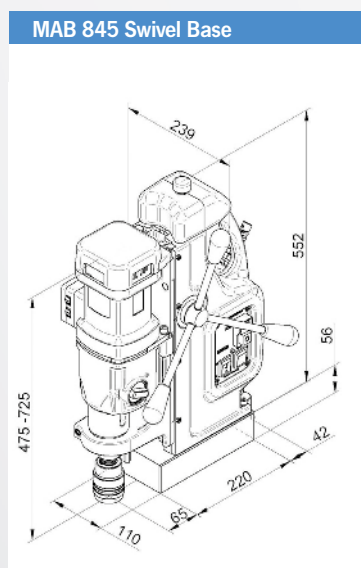
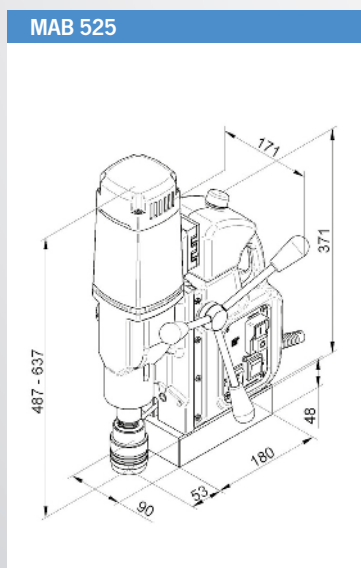
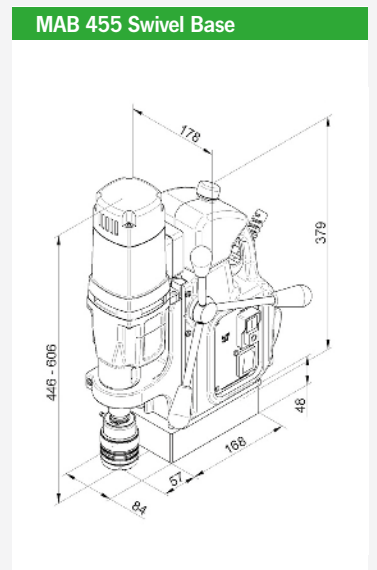
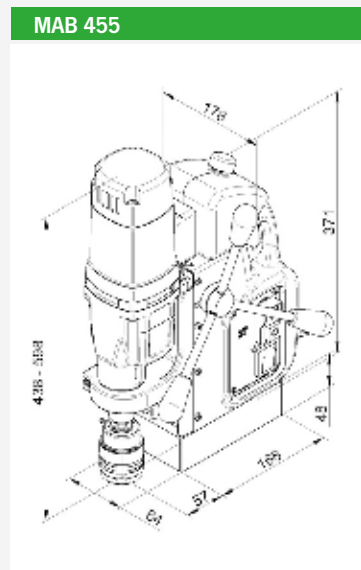
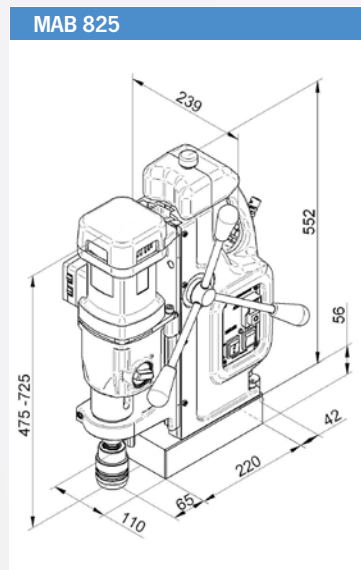
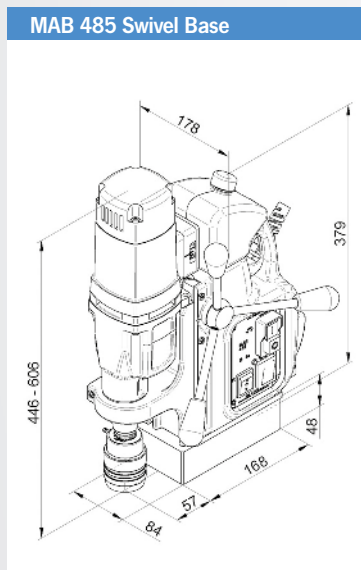
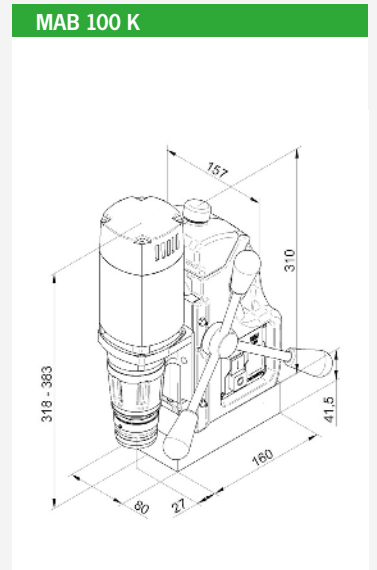
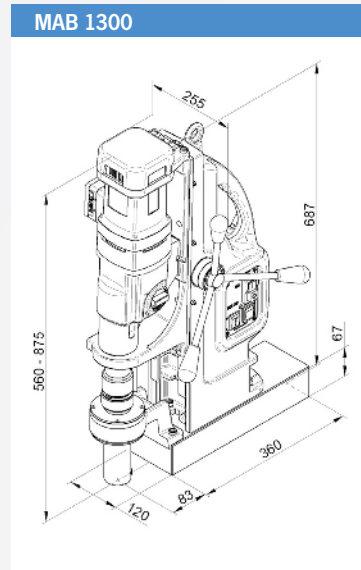
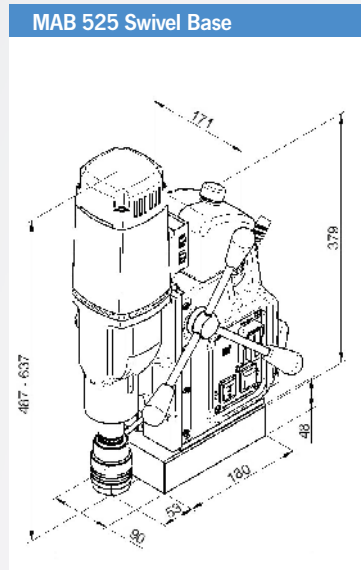
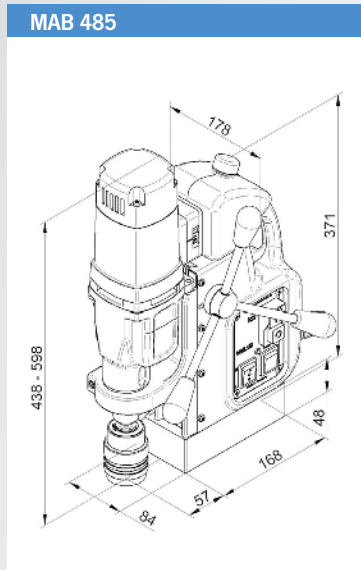

MABasic 200

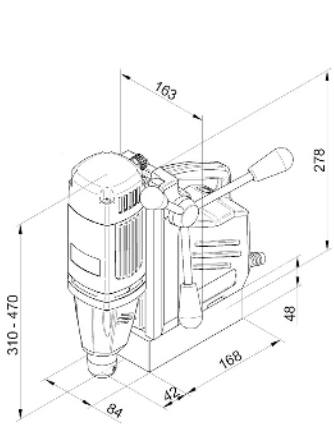

MABasic 850

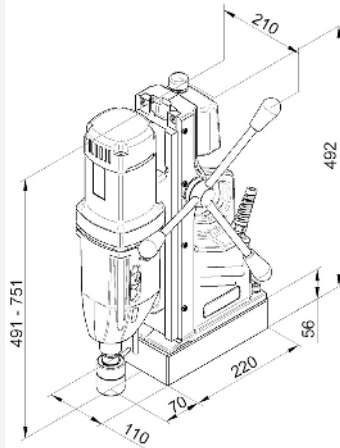

AutoMAB 450

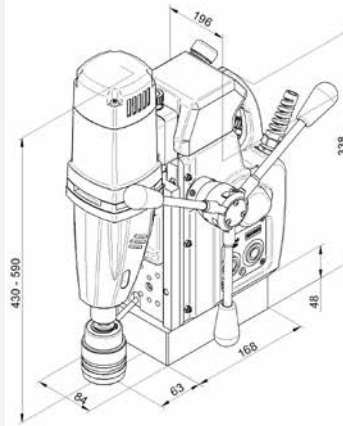

AirMAB 5000

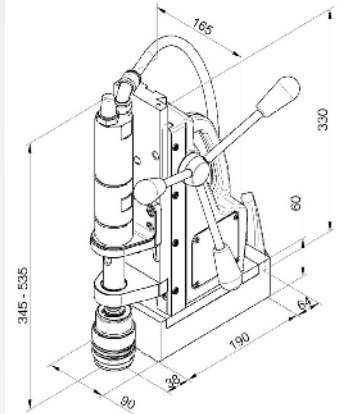

MABasic 400

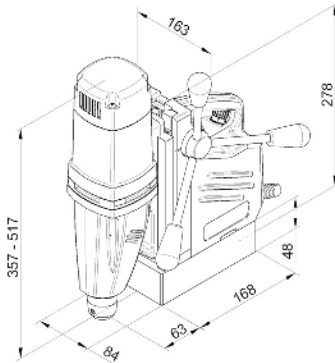

MAB 155

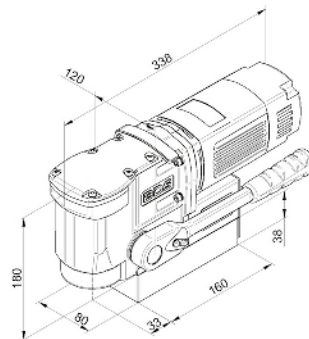

MAB 825 KTS

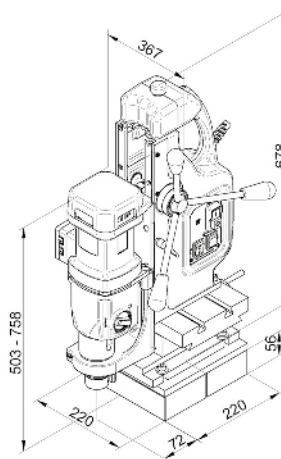

RailMAB 925

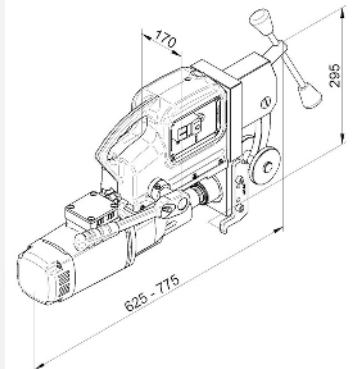

MABasic 450

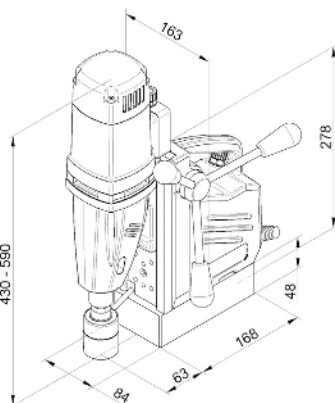

AutoMAB 350

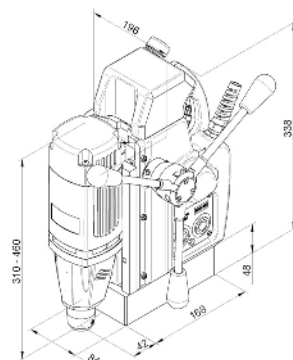

MAB 1300 V

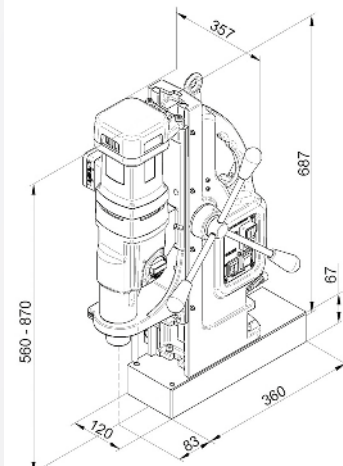

RailMAB 965

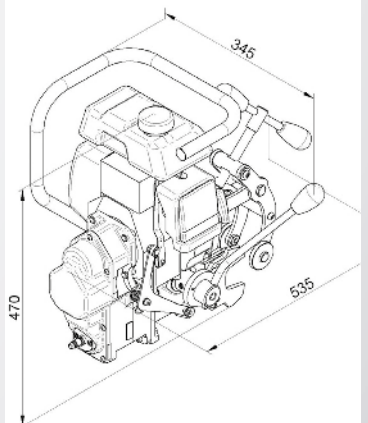



# Original BDS accessories makes work easier. BDS PowerWORKER, PowerCLEANER and the StarterKITS.

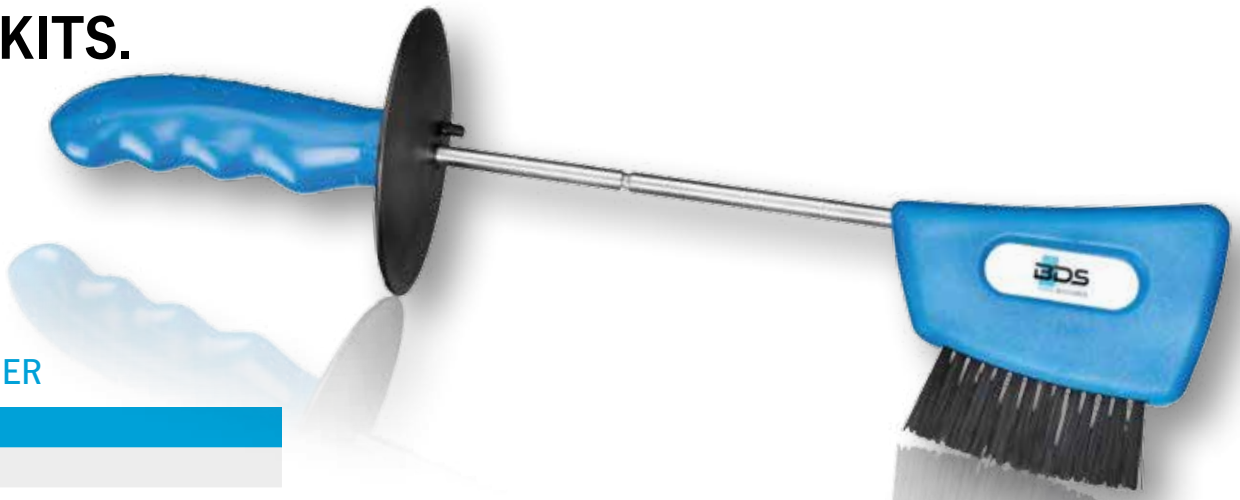

## PowerCLEANER

PowerCLEANER

ORDER NO.

POW 200



PowerCLEANER – An ideal two in one tool for removing the metal chips from the core drills with the special hook and then cleaning the chips from workplace with the special brush.



Remove sharp-edged metal chips



Clean the work surface

## The PowerCLEANER and PowerWORKER StarterKITS: High-quality necessary equipment at an attractive price!

Start with the right basic equipment for each magnetic core drilling machine. In one package at a very favourable price.

- ▶ 5 core drills, short, of the most common diameters: 14, 18 and 22 mm.
- ▶ 1 liter of High-performance cutting oil BDS 5000
- ▶ and one BDS PowerWORKER or one BDS PowerCLEANER.

### BDS StarterKIT PowerCLEANER

ORDER NO.

ZST 200

#### Contents:

- 1 Standard-Core Drill Box with
- 2 KBK – Ø 14 mm
- 2 KBK – Ø 18 mm
- 1 KBK – Ø 22 mm
- 1 liter of High-performance cutting oil BDS 5000
- 1 BDS PowerCLEANER



## Original BDS accessories for magnetic core drilling machines

The practical, universally usable BDS PowerWORKER and PowerCLEANER tools are indispensable in the workshop. Keep an eye out for the KITS at special prices!



### PowerWORKER

PowerWORKER

ORDER NO.

POW 100



Magnetise, collect together...



Demagnetise and finished!

The BDS PowerWORKER cleans up all magnetic drilling chips. With the help of this practical tool and its powerful magnetic force, chips are collected with ease and then placed quickly and easily in the scrap container. Magnetise, collect together, strip off and finished.

### BDS StarterKIT PowerWORKER

ORDER NO.

ZST 100

#### Contents:

- 1 Standard-Core Drill Box with
- 2 KBK – Ø 14 mm
- 2 KBK – Ø 18 mm
- 1 KBK – Ø 22 mm
- 1 liter of High-performance cutting oil BDS 5000
- 1 BDS PowerWORKER



BDS ÖkoLogisch





## Quick-change drill chuck and inserts for threads from M 6 to M 42

Magnetic core drilling machines of the ProfiPLUS class are ideally suited for thread cutting.

Basic requirements are: CW/CCW operation, full wave control electronics and high motor performance.

## Quick-change drill chuck size MK 2, MK 3 and MK 4

The large stroke range of the BDS magnetic core drilling machines, in conjunction with the quick-change chuck, facilitates fast and efficient working without having to repeat the aligning and centring when changing the tool.

The quick-change drill chuck can be universally used for the quick-change inserts with and without safety friction clutch.







# Thread cutting systems

For magnetic core drilling machines of the ProfiPLUS class.



Drilling, countersinking and thread cutting with a magnetic core drilling machine from BDS. Quickly, easily and with high precision.

## Option 1: Quick-change inserts with safety friction clutch

Threads from M 6 to M 42 – BDS inserts with safety friction clutch allow for precise threading of through-hole threads and blind-hole threads.

The safety friction clutch prevents tap fracture by contacting the bottom of the borehole.



## Option 2: Standard quick-change inserts

Threads from M 6 to M 30 – BDS inserts are suited for taking up of taps for through-hole threads.

# Which Machine? Which thread?

Assignment of machines of the ProfiPLUS class and the possible thread diameter to the size of the basic quick-change drill chucks and inserts.

## THREAD CUTTING SYSTEMS

### GSW Quick-change drill chucks:

In the versions MK 2, MK 3, MK 4. For taking up quick-change inserts GSE or GSS.

GSW 222 Size 2 MK 2

GSW 331 Size 1 MK 3

GSW 332 Size 2 MK 3

GSW 333 Size 3 MK 3

GSW 442 Size 2 MK 4

GSW 443 Size 3 MK 4

GSW 444 Size 4 MK 4



GSE  
Standard quick-change insert  
Size 1, 2, 3



GSS  
GSS Quick-change insert  
with safety friction clutch  
Size 2, 3, 4

## OVERVIEW

### ORDER NO.

GSW 222 Quick-change drill chuck	
GSW 331 Quick-change drill chuck	
GSW 332 Quick-change drill chuck	
GSW 333 Quick-change drill chuck	
GSW 442 Quick-change drill chuck	
GSW 443 Quick-change drill chuck	
GSW 444 Quick-change drill chuck	
GSE 103 – GSE 114 each	
GSE 205 – GSE 222 each	
GSE 314 – GSE 330 each	
GSS 205 – GSS 222 each	
GSS 312 – GSS 330 each	
GSS 420 – GSS 442 each	

## Tap adapters – getting started economically

By means of the adapter, the taps are taken up directly into the 19 mm or 32 mm Weldon system. Suitable for through-hole threads only!



### TAP ADAPTER WITH WELDON SHANK

ORDER NO.	THREAD	SHANK Ø	SQUARE
ZGA 010	M10 DIN 376	7	5.5
ZGA 012	M12 DIN 376	9	7
ZGA 014	M14 DIN 376	11	9
ZGA 016	M16 DIN 376	12	9
ZGA 018	M18 DIN 376	14	11
ZGA 020	M20 DIN 376	16	12
ZGA 022	M22 DIN 376	18	14.5
ZGA 024	M24 DIN 376	18	14.5
ZGA 027	M27 DIN 376	20	16
ZGA 030	M30 DIN 376	22	18

up to ZGA 020 with 19 mm Weldon shank ( $\frac{3}{4}$ "  
from ZGA 022 with 32 mm Weldon shank ( $1 \frac{1}{4}$ "

# THREAD CUTTING SYSTEMS

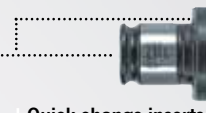

MAB 1300	MAB 825 MAB 845	MAB 525	MAB 485	Quick-change drill chucks GSW		Quick-change inserts Standard GSE		Quick-change inserts with safety friction clutch GSS			
				Order No.	Quick-change drill chuck	Thread	Order No.	ø x square	Order No.	ø x square	
					GSW 222	Size 2 MK 2	M5/M6	GSE 205	6 / 4.9	GSS 205	6 / 4.9
							M6			GSS 206	4.5 / 3.4
							M8	GSE 208	8 / 6.2	GSS 208	8 / 6.2
							M8			GSS 205	6 / 4.9
							M10	GSE 210-DIN 371	10 / 8		
							M10	GSE 210	7 / 5.5	GSS 210	7 / 5.5
							M12	GSE 212	9 / 7.0	GSS 212	9 / 7.0
							M14	GSE 214	11 / 9.0	GSS 214	11 / 9.0
							M16	GSE 216	12 / 9.0	GSS 216	12 / 9.0
					GSW 331	Size 1 MK 3	M4	GSE 104	4.5 / 3.4		
							M5/M6	GSE 105	6 / 4.9		
							M8	GSE 108	8 / 6.2		
							M10	GSE 110	10 / 8.0		
							M12	GSE 112	9 / 7.0		
							M14	GSE 114	11 / 9.0		
					GSW 332	Size 2 MK 3	M5/M6	GSE 205	6 / 4.9	GSS 205	6 / 4.9
							M6			GSS 206	4.5 / 3.4
							M8	GSE 208	8 / 6.2	GSS 208	8 / 6.2
							M8			GSS 205	6 / 4.9
							M10	GSE 210.1	10 / 8		
							M10	GSE 210	7 / 5.5	GSS 210	7 / 5.5
							M12	GSE 212	9 / 7.0	GSS 212	9 / 7.0
							M14	GSE 214	11 / 9	GSS 214	11 / 9
							M16	GSE 216	12 / 9	GSS 216	12 / 9
							M18	GSE 218	14 / 11	GSS 218	14 / 11
							M20	GSE 220	16 / 12	GSS 220	16 / 12
					*not suitable for MAB 525	M22/M24*		GSE 222	18 / 14.5	GSS 222	18 / 14.5
					GSW 333	Size 3 MK 3	M12			GSS 312	9 / 7.0
							M14	GSE 314	11 / 9	GSS 314	11 / 9
							M16	GSE 316	12 / 9	GSS 316	12 / 9
							M18	GSE 318	14 / 11	GSS 318	14 / 11
							M20	GSE 320	16 / 12	GSS 320	16 / 12
							M22/M24	GSE 322	18 / 14.5	GSS 322	18 / 14.5
							M27	GSE 327	20 / 16	GSS 327	20 / 16
							M30	GSE 330	22 / 18	GSS 330	22 / 18
					GSW 442	Size 2 MK 4	M5/M6	GSE 205	6 / 4.9	GSS 205	6 / 4.9
							M6			GSS 206	4.5 / 3.4
							M8	GSE 208	8 / 6.2	GSS 208	8 / 6.2
							M8			GSS 205	6 / 4.9
							M10	GSE 210-DIN 371	10 / 8.0		
							M10	GSE 210	7 / 5.5	GSS 210	7 / 5.5
							M12	GSE 212	9 / 7.0	GSS 212	9 / 7.0
							M14	GSE 214	11 / 9	GSS 214	11 / 9
							M16	GSE 216	12 / 9	GSS 216	12 / 9
							M18	GSE 218	14 / 11	GSS 218	14 / 11
							M20	GSE 220	16 / 12	GSS 220	16 / 12
							M22/24	GSE 222	18 / 14.5	GSS 222	18 / 14.5
					GSW 443	Size 3 MK 4	M12			GSS 312	9 / 7.0
							M14	GSE 314	11 / 9	GSS 314	11 / 9
							M16	GSE 316	12 / 9	GSS 316	12 / 9
							M18	GSE 318	14 / 11	GSS 318	14 / 11
							M20	GSE 320	16 / 12	GSS 320	16 / 12
							M22/24	GSE 322	18 / 14.5	GSS 322	18 / 14.5
							M27	GSE 327	20 / 16	GSS 327	20 / 16
							M30	GSE 330	22 / 18	GSS 330	22 / 18
					GSW 444	Size 4 MK 4	M20			GSS 420	16 / 12
							M22/24			GSS 422	18 / 14.5
							M27			GSS 427	20 / 16
							M30			GSS 430	22 / 18
							M33			GSS 433	25 / 20
							M36			GSS 436	28 / 22
							M39/42			GSS 442	32 / 24



# Carry cases and adapters

Carry cases for magnetic core drilling machines and EKF edge processing machines. Adapters for drill chuck and gear rim drill chuck.

## Carry cases for magnetic core drilling machines

The new carry cases developed by BDS for magnetic core drilling machines have many benefits.

- ▶ Portable – low weight with high level of stability at the same time.
- ▶ Closed firmly – secure and large mechanical locks.
- ▶ Sealed – the contents are protected completely against dust and spray water.
- ▶ Roll along instead of carry – ABS wheels and telescopic grip.

BDS Maschinen develops products from the ergonomic points of view.

The new carry case provided with wheels for magnetic core drilling machines of the MAB 1300 series has large, robust ABS wheels and a telescopic grip, which facilitate transporting the heavy machine to a large extent and make it safe.

The MAB 1300 is fitted safely and securely in robust plastic bowls that absorb the heavy weight of the machine ideally.



### HARD PROTECTIVE CASE

#### ORD. NO. SUITABLE FOR

ZHK 100 MAB 100, MAB 150  
ZHK 400 MAB 455, MAB 485, MAB 525

**Application:** Carry case for BDS magnetic core drilling machines. **Design:** Robust hard cover case with handle and stable clasps. With foam padding, no contents.

### CARRY CASE

#### ORD. NO. SUITABLE FOR

ZPK 001 EKF 300, EKF 450, EKF 452

**Application:** Carry case for EKF 300, EKF 450 and EKF 452.

**Design:** Plastic case with handle and foam padding, no contents.



### CARRY CASE ON WHEELS

#### ORD. NO. SUITABLE FOR

ZHK 1300 MAB 1300

**Application:** Carry case on wheels for BDS magnetic core drilling machines. **Design:** Robust carry case on wheels with handle and stable clasps. No contents.



### CARRY CASE ON WHEELS

#### ORD. NO. SUITABLE FOR

ZHK 825 MAB 825, MAB 845

**Application:** Carry case on wheels for BDS magnetic core drilling machines. **Design:** Robust carry case on wheels with handle and stable clasps. No contents.



The robust carry case on wheels.

BDS hard cover cases and carry cases on wheels are robust, watertight and shockproof.



1. Connect adapter to drill chuck.



2. Place drill chuck in direct arbor.



3. Ready for use with twist drill.

For magnetic core drilling machines with direct arbor  
19 mm Weldon ( $\frac{3}{4}$ "")

- ProfiSTART** MAB 100
- ProfiBASIC** MABasic 200  
MABasic 400
- ProfiSPEZIAL** AutoMAB 1500  
AkkuMAB 3000



**ADAPTER FOR DRILL CHUCKS**

**ORDER NO.**

ZAP 100  
Weldon shank 19 mm ( $\frac{3}{4}$ "") to  $\frac{1}{2}$ " x 20 NF



**GEAR RIM DRILL CHUCK**

**ORD. NO. INTERNAL THREAD CLAMP SIZE**

ZBI 113	$\frac{1}{2}$ " x 20 NF	1 - 13 mm
ZBI 116	$\frac{1}{2}$ " x 20 NF	2,5 - 16 mm



**QUICK-ACTION DRILL CHUCK**

**ORD. NO. INTERNAL THREAD CLAMP SIZE**

ZSI 113	$\frac{1}{2}$ " x 20 NF	1 - 13 mm
ZSI 116	$\frac{1}{2}$ " x 20 NF	3 - 16 mm



1. Connect taper drift to drill chuck.



2. Place drill chuck in MT arbor.



3. Ready for use with twist drill.

For magnetic core drilling machines with Morse taper MK 2 or MK 3.

- ProfiPLUS** MAB 485 / 485 SB  
MAB 485  
MAB 525 / 525 SB  
MAB 825 / 845 SB  
MAB 1300
- ProfiSTART** MAB 455 / 455 SB  
MAB 855
- ProfiBASIC** MABasic 450
- ProfiSPEZIAL** AirMAB 5000



**TAPER DRIFT FOR DRILL CHUCK**

**ORDER NO.**

ZKD 216 DIN 238 - MK 2/B16  
ZKD 316 DIN 238 - MK 3/B16



**GEAR RIM DRILL CHUCK**

**ORD. NO. INTERNAL THREAD CLAMP SIZE**

ZBK 113	DIN 238-B16	1 - 13 mm
ZBK 116	DIN 238-B16	2,5 - 16 mm



**QUICK-ACTION DRILL CHUCK**

**ORD. NO. INTERNAL THREAD CLAMP SIZE**

ZSB 113	DIN 238-B16	1 - 13 mm
ZSB 116	DIN 238-B16	3 - 16 mm



**KEY FOR GEAR RIM DRILL CHUCK**

**ORDER NO.**

ZEZ 113  
ZEZ 116



**CHIP PROTECTION**

**ORD. NO. MACHINE**

ZSS 050	MAB 100 - MAB 525
ZSS 500	MAB 825 - MAB 855



**DRILL DRIFT DIN 228**

**ORD. NO. SIZE DIN STANDARD**

ZAS 002	MK 2	DIN 228
ZAS 003	MK 3	DIN 228

**SAFETY CHAIN**

**ORDER NO.**

ZSK 001

**PUMP BOTTLE**

**ORDER NO.**

ZKP 100



# Tool holders and Adapters

For BDS core drills with Weldon shank – suitable for third-party systems with adaption. Tool holders for BDS core drills with Weldon holder. There are now a total of three systems to choose from, which enable a stable, comfortable and safe connection between the core drill and the magnetic core drilling machine.

Tool holder for BDS core drills with 19 mm ( $\frac{3}{4}$ " ) Weldon shank



## QUICK CHANGE DRILL CHUCK SYSTEM KEYLESS

### ORDER NO. SPINDLE HOLDER

ZSS 200 MK 2

ZSS 300 MK 3

With automatic internal lubrication for core drills with 19 mm ( $\frac{3}{4}$ " ) Weldon shank. With hose and quick acting coupling. Quick tool change without a chuck key.

Tool holder for BDS core drills with 19 mm ( $\frac{3}{4}$ " ) and 32 mm ( $1\frac{1}{4}$ " ) Weldon shank



## INDUSTRIAL ARBOR WITH MANUAL INTERNAL LUBRICATION

### ORDER NO. SPINDLE HOLDER

ZIA 219-M MK 2

ZIA 319-M MK 3

ZIA 419-M MK 4

For BDS core drills with 19 mm ( $\frac{3}{4}$ " ) Weldon shank

ZIA 332-M MK 3

ZIA 432-M MK 4

For BDS core drills with 32 mm ( $1\frac{1}{4}$ " ) Weldon shank

Tool holder for BDS core drills with 19 mm ( $\frac{3}{4}$ " ) and 32 mm ( $1\frac{1}{4}$ " ) Weldon shank



## INDUSTRIAL ARBOR WITH AUTOMATIC INTERNAL LUBRICATION

### ORDER NO. SPINDLE HOLDER

ZIA 219-KN MK 2

ZIA 319-KN MK 3

ZIA 419-KN MK 4

For BDS core drills with 19 mm ( $\frac{3}{4}$ " ) Weldon shank

ZIA 332-KN MK 3

ZIA 432-KN MK 4

For BDS core drills with 32 mm ( $1\frac{1}{4}$ " ) Weldon shank

With hose and quick acting coupling.



## REDUCING BUSH DIN 2185

### ORDER NO. OUTSIDE INSIDE

ZRH 210 MK 2 MK 1

ZRH 320 MK 3 MK 2

ZRH 430 MK 4 MK 3



## EXTENSION BUSH DIN 2178

### ORDER NO. OUTSIDE INSIDE

ZVH 220 MK 2 MK 2







ZVH 320 MK 3 MK 2

ZVH 330 MK 3 MK 3



# Adapters with Weldon shank

Adapters for BDS core drills. With the appropriate adapters, BDS core drills with Weldon shanks are compatible with all standard machines and tool holder systems on the market.

32 mm (1 1/4")	19 mm (3/4")	19 mm (3/4")	19 mm (3/4")	Adapter for Nitto One-touch	Adapter for Fein QUICK-IN
					
<b>ADAPTER</b> <b>ORDER NO.</b> ZAP 200	<b>ADAPTER</b> <b>ORDER NO.</b> ZAF 002	<b>ADAPTER</b> <b>ORDER NO.</b> ZAF 003	<b>EXTENSION</b> <b>ORDER NO.</b> ZAP 300	<b>ADAPTER</b> <b>ORDER NO.</b> ZAF 005	<b>ADAPTER</b> <b>ORDER NO.</b> ZAF 004
From 32 mm Weldon shank (1 1/4") to 19 mm Weldon shank (3/4")	For Fein core drills with internal thread M18 x 6 P1.5 incl. 1 ejector pin ZAK 125	For Fein core drills with QUICK-IN-shank incl. 1 ejector pin ZAK 115	80 mm, 19 mm Weldon shank (3/4"), incl. 1 ejector pin ZAK 080	With Nitto one-touch holder for core drills with 19 mm (3/4") Weldon shank each incl. 1 ejector pin ZAK 107 und 125	With Quick-in holder for core drills with 19 mm (3/4") Weldon shank each incl. 1 ejector pin ZAK 107 und 125



## Clamping devices for tubes from 80 mm to 500 mm diameter

The BDS clamping devices are suitable for tubes with a diameter from 80 to 250 mm and 150 to 500 mm. Flexible and quick clamping is possible in any drilling situation. The clamping device with swivelling V-blocks is fixed on the tube by means of tension chains. The drilling position on the tube can be adjusted easily and safely. The range of application of the magnetic core drilling machines of the ProfiPLUS series is significantly increased by these devices.



ZRO 250



ZRO 500

### TUBE CLAMPING DEVICE

#### ORDER NO.

ZRO 250

ZRO 500

**ZRO 250:** for MAB 455, 485, 525

For tube  $\varnothing$ : 80 – 250 mm

Chain length: 900 mm

**ZRO 500:** for MAB 825, 845, 855

For tube  $\varnothing$ : 150 – 500 mm

Chain length: 1.650 mm





# Clamping devices

For magnetic core drilling machines of the ProfiPLUS and ProfiSTART class. For tube processing and drilling of non-ferrous metals and stainless steel.

## Vacuum clamping device for non-ferrous metals

Magnetic core drilling machines from the ProfiPLUS class can in their entirety also be used for the processing of non-ferrous metals and stainless steel. For that purpose, BDS offers clamping devices, which are provided with a pump with circular oil lubrication to build up a vacuum to ensure a safe connection between the magnetic core drilling machine and the workpiece.

Furthermore, BDS offers customized devices, which exactly meet your requirements and instructions. Just contact us!



### VACUUM PLATE FOR SMOOTH SURFACES

#### ORDER NO.

ZAV 400

**Application:** For smooth surfaces.

**Design:** High-performance vacuum pump with circular oil lubrication. Clamping plate with two suction areas and internal drilling area.

Size: 440 x 260 mm, long hole: 50 x 120 mm

ZAV 400  
Vacuum clamping device  
for smooth surfaces



ZAV 300  
Vacuum clamping device  
for channelled and  
gusset plates



### VACUUM PLATE FOR CHANNELLED AND GUSSET PLATES

#### ORDER NO.

ZAV 300

**Application:** Suitable for channelled and gusset plates.

**Design:** High-performance vacuum pump with circular oil lubrication. Clamping plate  $\varnothing$  300 mm.



# Pillars and clamping devices

Magnetic pillars for your own twist drilling machine, MobilCLAMP and drill stands.

**Build your own magnetic drilling machine!** BDS provides new options for the subject of clamping mechanisms for working with commercially available manual drilling machines and for magnetic core drilling machines.



Magnetic pillar



Industrial pillar



MobilCLAMP – mobile working with magnetic core drilling machines

## Magnetic pillars for hand drills

Using this practical magnetic drilling stand, you can convert your manual drilling machine into a magnetic drilling machine.

The magnetic drilling stand is suitable for commercially available manual drilling machines with 43 mm collar diameter.

Thus, the powerful magnet facilitates working horizontally and doing overhead work safely. (For these applications, a safety chain must be used additionally.) The carriage has a working stroke of 180 mm.

## Industrial pillar for twist drilling machines

Industrial drilling stand for commercially available manual drilling machines with 43 mm collar diameter.

Safe, secure and stable by a cast base plate and carriage with a working stroke of 180 mm.

Optionally with a drilling machine vice, 100 mm jaw width. Screws for T-grooves are also available for securing.

## MobilCLAMP for BDS magnetic core drilling machines



Using the portable clamping mechanism, MobilCLAMP, you can supplement the application options of a magnetic core drilling machine onsite and in the workshop. The magnetic core drilling machine is placed on the desired surface for this purpose

and switched on. Components can be clamped securely in the quick-action clamping vice and you have a flexible table-top drilling machine in no time.

Optionally available: stable frame for MobilCLAMP clamping device.



**MAGNETIC PILLARS**

**ORDER NO.**

MBS 300

For commercially available hand drills with a collar diameter of 43 mm, stroke 160 mm.



**INDUSTRIAL PILLAR**

**ORDER NO.**

ZBS 100

For commercially available hand drills with a collar diameter of 43 mm, stroke 180 mm. Vice and screws are not included in the delivery.



**PRISM VICE**

**ORDER NO.**

ZST 300 Prism vice

ZTN 100 Screw for T slots

ZSM 100 Hexagon nut

Jaw width: 100 mm, clamping range: 100 mm

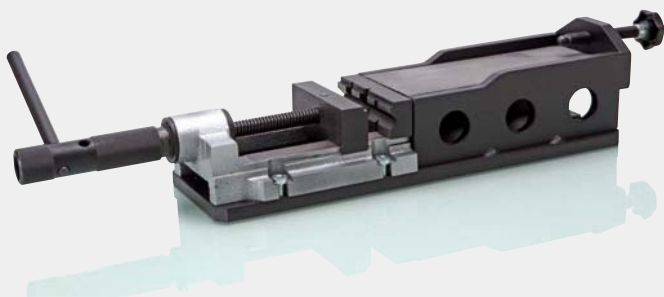

**CLAMPING DEVICE MobilCLAMP**

**ORDER NO.**

**JAW WIDTH**

ZMC 180

100 cm, 80 mm clamping width

ZMC 300

Base frame for clamping device

Mechanical clamping device for magnetic core drilling machines.



**MAGNETIC CLAMPING DEVICE MagnetCLAMP**

**ORDER NO.**

**CLAMPING RANGE**

ZMS 500/230V

100 – 800 mm

ZMS 500/120V

100 – 800 mm

Magnetic clamping device, the versatile mounting aid.



### High-performance cutting oil **BDS 5000**

### Cooling lubricant **BDS 6000**



Recommended for High Speed Steel Core Drills. Pure vegetable oil that is not a hazardous good in the context of import-export regulations. The base materials used are not described in the catalogue of water endangering substances. BDS 5000 do not have to be specifically labelled.

- ▶ Organic basis material with additives
- ▶ Water hazard class 1
- ▶ Bio-degradable, optimal base adjustment of the viscosity for the use of BDS core drills, and easy use for subsequent galvanising



Recommended for Carbide (TCT) Core Drills. For high demands based on synthetic raw materials.

- ▶ Soluble with water, biostable and mild smelling
- ▶ Improves the core drill service life
- ▶ Toxicologically harmless, water hazard class 1



CUTTING OIL		
ORDER NO.	NAME	CONTENT
ZHS 005	BDS 5000 cutting oil	5 Liter Can
ZHS 006	BDS 5000 cutting oil	1 Liter Can

COOLING LUBRICANT		
ORDER NO.	NAME	CONTENT
ZHB 001	BDS 6000 Cooling lubricant	1 Liter Can



# Cutting oil, lubrication spray, lubrication paste and cooling lubricant

High-performance, which can be applied effectively and is environmentally friendly.

The best working result - for the nature!!

High-performance lubricants and cleaning spray by BDS are aligned perfectly to the respective application. The highly efficient composition allows economical and environmentally friendly use.

Particularly recommended in outdoor application: BDS high-performance cutting oil or high-performance soluble cooling lubricant. These products are bio-degradable without leaving any residues and toxicologically harmless. However, at the same time, they are highly effective in the desired lubricating and cooling performance. In addition, the BDS 6000 soluble can be mixed with water in the ratio 1:10 and is thus, high-yield.

## High-performance lubrication spray **BDS 5200**



Suitable for working under special conditions (overhead and vertical surface) and also for high-alloy materials.

Foam-like spray with very high adhesive force.

Advantages: Exact dosage of the lubrication spray and thus, optimal lubrication directly on the drill cutters. No drop formation and spraying around, and thus, maximum occupational safety on ladders and work platforms.

- ▶ White adhesive lubricant containing PTFE with corrosion protection
- ▶ Free from PCB, PCT, FCKW and chlorine
- ▶ Active ingredient: Lithium base grease on mineral basis with additives and solvent
- ▶ Propellant: Propane/Butane, to be specified

**Caution: Do not use liquid lubricants when working overhead or on vertical surfaces. In such a case, oil might get into the motor causing short-circuit. Please, use BDS High-performance lubrication spray BDS 5200.**



## High-performance-Cutting paste **BDS 5500**



Optimally suitable for material types that are difficult to machine such as high-alloy steels, Hardox, stainless and heat-resistant steels. Suitable for use overhead and for work in constrained spaces. Ideal for tapping or thread cutting tools.



Step 1: Prior to drilling, spray the high-performance lubrication spray directly into the drill.



Step 2: During drilling, spray the high-performance lubrication spray onto the tip of the drill and into the cut hole.

### CUTTING PASTE

ORDER NO.	NAME	CONTENT
ZHS 550	BDS 5500 Cutting paste	1000 g Can

### LUBRICATION SPRAY

ORDER NO.	NAME	CONTENT
ZHS 400	BDS 5200 lubrication spray	1 x 400 ml Can
ZHS 406	BDS 5200 lubrication spray	6 x 400 ml Can
ZHS 412	BDS 5200 lubrication spray	12 x 400 ml Can

# Fully Ground High Speed Steel (HSS) Core Drills

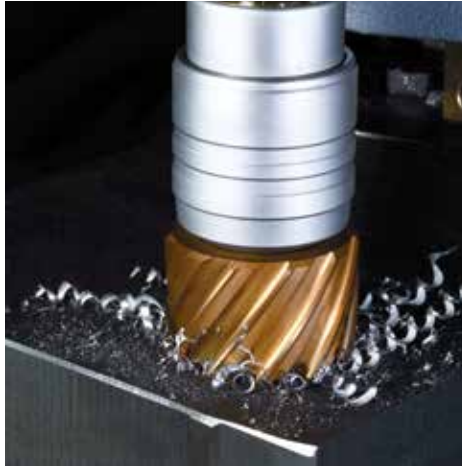

## HSS-Co 8 Series

- ▶ High thermal resistance
- ▶ Better wear protection
- ▶ High proportion of cobalt at 8 %
- ▶ Suitable for higher levels of stress in fine-grained steel and stainless material
- ▶ With 19 mm or 32 mm Weldon shank
- ▶ Regrindable

## HSS-VarioPLUS Series

- ▶ High-strength fully ground core drills
- ▶ Hard coating in the range of 2.5 μ
- ▶ Longer life
- ▶ More uniform removal of chips, particularly with long drills – an important aspect for occupational safety

## HSS-Standard Series

- ▶ Tools with three different cutting depths: 30 mm, 55 mm and 110 mm
- ▶ Core drill diameters from 12 mm to 130 mm
- ▶ Regrindable



HSS-Co 8 Series	
KBK-CO	KBL-CO
Cutting depth: 30 mm	55 mm
Drill diameter: 12 – 130 mm	12 – 100 mm



HSS-VarioPLUS Series	
KBK-VP	KBL-VP
Cutting depth: 30 mm	55 mm
Drill diameter: 12 – 60 mm	12 – 60 mm



HSS-Standard Series			
KBK	KBL	KEL	KBK-Z
Cutting depth: 30 mm	55 mm	110 mm	30 mm
Drill diameter: 12 – 60 mm	12 – 60 mm	20 – 50 mm	1/2" – 2 1/16"

# Professional Quality Tungsten Carbide Tip (TCT) Core Drills



BDS core drills are manufactured on state of the art CNC-controlled grinding centres. This guarantees consistent grinding, quality and cutting performance for all BDS drilling tools in the entire product spectrum.

## Extensive programme range

BDS core drilling tools are produced in five cutting depths of 30, 35, 55, 75 and 110 mm and with more than 94 different drill diameters.

## Tool holders

BDS core drilling tools are available with various tool holders. They fit in the KEYLESS quick change drill chuck system as well as in the industrial arbors MK 2, MK 3 and MK 4 with automatic or manual internal lubrication, which are available in our range of accessories.

## Carbide Series and Carbide-PLUS Series (TCT)

- ▶ Carbide-tipped (TCT) core drills
- ▶ Cutting depths of 30 mm, 55 mm, 75 mm and 110 mm
- ▶ Diameters from 12 mm to 150 mm
- ▶ Carbide PLUS with additional wear resistant carbide coating of up to 2.5 µ



### Tool holders:

- ① 19 mm Weldon shank (3/4")
- ② 32 mm Weldon shank (1 1/4")
- ③ 18 mm Quick-In shank

## Carbide Series

Carbide-tipped (TCT) core drills. For the processing of stainless steel and non-ferrous metals, we recommend using the high-performance water soluble cooling lubricant BDS 6000.



## Carbide-PLUS Series

Carbide-tipped (TCT) core drills with carbide coating.



## Carbide-RAIL Series

Carbide-tipped (TCT) core drills for rail core drilling machines.



## Quick-In Series

**HSS-Co 8-F/Carbide**  
Core drills made of HSS tool steel or carbide tipped. Suitable for Quick-in tool holder systems.



### Carbide Series

HKK	HKL	HKX-L	HKE-L
30 mm	55 mm	75 mm	110 mm
12 – 150 mm	12 – 100 mm	18 – 120 mm	20 – 120 mm

### Carbide-PLUS Series

HKK-P
30 mm
12 – 60 mm

### Carbide-RAIL Series

HKK-R
30 mm
17 – 36 mm

### Quick-In Series

KBK-CO 8 F	HKK-F
35 mm	35 mm
12 – 60 mm	12 – 60 mm



Our call centre is at your disposal.



You can contact our call centre in Mönchengladbach from Mondays to Thursdays between 8 am and 5 pm and Fridays from 8 am to 4 pm German time. +49 (0)2161-3546-0

## BDS contact details.

### BDS Maschinen GmbH

Martinstrasse 108  
D-41063 Mönchengladbach  
Telephone: +49(0)2161-3546-0  
Fax: +49(0)2161-3546-15  
Internet: [www.bds-maschinen.de](http://www.bds-maschinen.de)  
[www.bds-machines.com](http://www.bds-machines.com)  
E-mail: [info@bds-maschinen.de](mailto:info@bds-maschinen.de)

### Sales Germany

E-mail: [verkauf@bds-maschinen.de](mailto:verkauf@bds-maschinen.de)  
Telephone: +49(0)2161-3546-0

### International Sales

E-mail: [export@bds-maschinen.de](mailto:export@bds-maschinen.de)  
Telephone: +49(0)2161-3546-18

### Spare parts and repair

E-mail: [technik@bds-maschinen.de](mailto:technik@bds-maschinen.de)  
Telephone: +49(0)2161-3546-38

### BDS Maschinen Austria

Dorfplatz 1  
A-6170 Zirl  
Telephone: +43(0)5238 /52383  
Fax: +43(0)5238 /52977  
E-mail: [bds-maschinen@aon.at](mailto:bds-maschinen@aon.at)

## Call up demo videos.



You can always find new and interesting videos of our machines on our website. They make application possibilities clearer and connections more obvious. See for yourself what is possible with BDS magnetic core drilling technology and edge processing machines.

## BDS on the Internet: bds-maschinen.de

Always find the latest information on the whole delivery process. Download area with videos, instruction manuals and further product information. Click and enter.

## BDS Official App for Apple, Android and Blackberry



The brand new BDS Apps for Apple (iPhone, iPad), Android smart phones, Windows smart phones and Blackberry now available on Apple App Store, Google Play, Windows Store and Blackberry World for free. The App comes with interesting features like Calculate cutting speed for ProfiPLUS machines, Compare machines and core drills, Find machine, Digital catalogue and much more. Search for: BDS Machines



## BDS on Facebook & Co.



Like us on  
[www.facebook.com/bdsmachines](http://www.facebook.com/bdsmachines)



Follow us on  
[www.twitter.com/bdsmachines](http://www.twitter.com/bdsmachines)



Connect us on  
[www.linkedin.com/company/bds-maschinen-gmbh](http://www.linkedin.com/company/bds-maschinen-gmbh)

## BDS Maschinen in specialised trade.



You can also find magnetic core drilling machines, accessories and core drills by BDS Maschinen in all good specialised tool stores. Our committed on-site sales partners are happy to advise you and work closely with BDS Maschinen experts to offer you the right tool for your job.

# The BDS network – always available

See our performance for yourself.

Customers and users can always contact BDS Maschinen: with personalised advice from competent experts, a fast parts replacement service and detailed product information on magnetic core drilling technology and edge processing. Take us at our word.

## Personalised advice

BDS experts in our sales department are available all over Germany to present our products and demonstrate them on-site. Questions about magnetic core drilling technology or edge processing?

For personalised expert advice, contact our centre in Mönchengladbach. You will be put through to the relevant administrator or we will call you back. We look forward to your call! Telephone: +49 (0)2161-3546 -0

## Newsletter

You can automatically receive constant information from BDS Maschinen on new products and interesting reports and practical solutions by registering on our homepage.

## Express-Service

We can express deliver your order upon request. Talk directly to our administrators. Telephone: +49 (0)2161-3546 -0

## Legal information

Subject to technical modifications. Reprint (even extracts) only with written permission from BDS Maschinen GmbH, Mönchengladbach. Errors and printing errors excepted.

Issue D 2017 Printed in Germany

# DO YOU HAVE ANY QUESTIONS? WE HAVE THE ANSWERS!

Contact us in person, on the web or via the app, from wherever you want.



Subject to technical modifications. Reprint (even extracts) only with written permission from BDS Maschinen GmbH, Mönchengladbach. Errors and misprint excepted. Issue EN 2016. Printed in Germany

**BDSMASCHINEN**  
MADE IN GERMANY

**BDS**  
MASCHINEN

BDS Maschinen GmbH  
Martinstraße 108  
D-41063 Mönchengladbach  
Phone +49(0)2161/35 46-19  
Fax +49(0)2161/35 46-15  
[www.bds-maschinen.de](http://www.bds-maschinen.de)  
[export@bds-maschinen.de](mailto:export@bds-maschinen.de)

